

DESCRIPTION

The EV2420-F-00A is an evaluation board for MPMPQ2420GF, a synchronous step-down switching regulator with integrated high-side/low-side, high-voltage power MOSFETs. It provides a highly efficient output of up to 0.3A. The integrated watchdog adds an additional security redundancy to the system.

It allows for high power conversion efficiency over a wide load range by scaling down the switching frequency under light-load condition to reduce the switching and gate driver losses.

The EV2420-F-00A is assembled and tested with TSSOP-16 EP package.

ELECTRICAL SPECIFICATION

Parameter	Symbol	Value	Units
Input Voltage	V_{IN}	4.5–75	V
Output Voltage	V_{OUT}	3.3	V
Output Current	I_{OUT}	0.3	A

FEATURES

- 20 μ A Quiescent Current (Active mode)
- Wide 4.5V to 75V Operating Input Range
- 1.2 Ω /0.45 Ω Internal Power MOSFETs
- Programmable Soft-Start
- FB-Tolerance: 1% at Room Temperature; 2% at Full Temperature
- Adjustable Output Voltage
- Integrated Windowed Watchdog
- Power on Reset during Power-up and Under voltage
- Programmable Short Window Mode or Long Window Mode
- Low Shutdown Mode Current: 5 μ A
- TSSOP-16 EP Package
- Available in AEC-Q100 Grade 1

APPLICATIONS

- Automotive Systems
- Industrial Power Systems
- Distributed Power Systems
- Battery Powered Systems

All MPS parts are lead-free and adhere to the RoHS directive. For MPS green status, please visit MPS website under Products, Quality Assurance page.

"MPS" and "The Future of Analog IC Technology", are Registered Trademarks of Monolithic Power Systems, Inc.

EV2420-F-00A EVALUATION BOARD



(L × W × H) 6.3cm × 6.3cm × 0.5cm

Board Number	MPS IC Number
EV2420-F-00A	MPQ2420GF

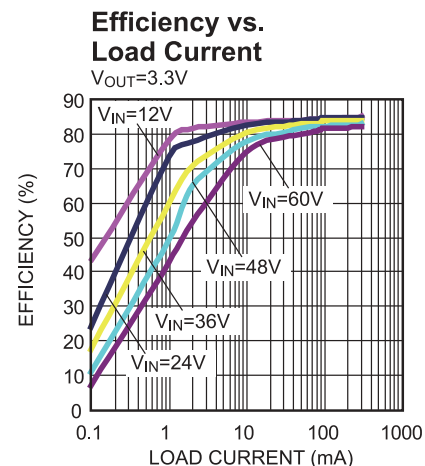

EVALUATION BOARD SCHEMATIC

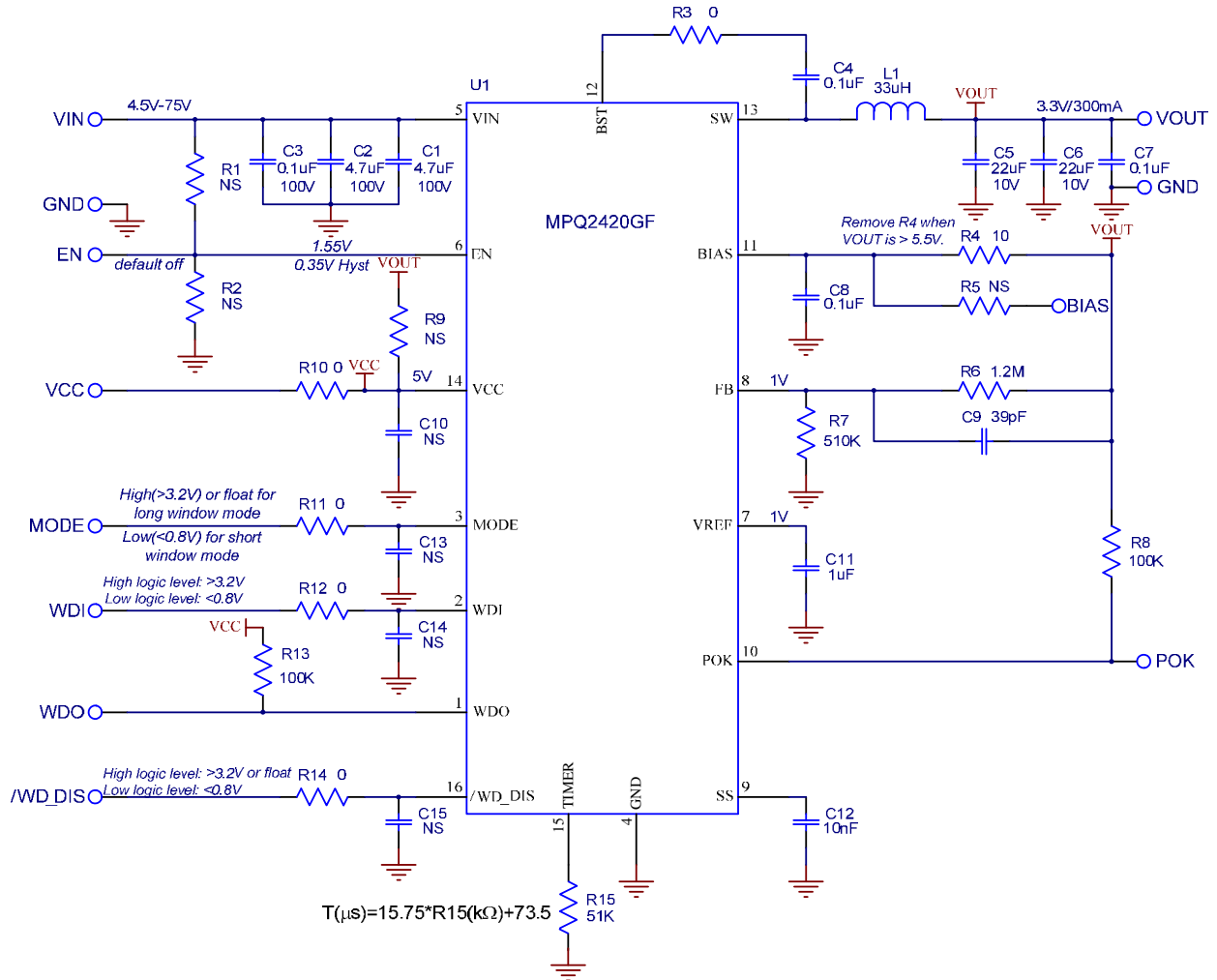

$$T(\mu s) = 15.75 * R15(k\Omega) + 73.5$$

Reference for FB Divider Selection

VOUT (V)	R7 (kΩ)	R6 (kΩ)
3.3	510 (1%)	1200 (1%)
5	301 (1%)	1200 (1%)
12	110 (1%)	1200 (1%)

Package Reference

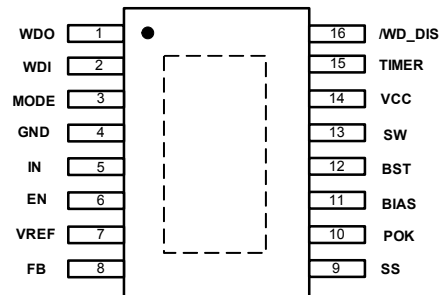

TSOP-16 EP

EV2420-F-00A BILL OF MATERIALS

Qty.	Designator	Value	Description	Package	Manufacture	Manufacture PN
2	C1, C2	4.7uF	Ceramic Capacitor; 100V;X7S;1210	1210	TDK	C3225X7S2A475K
1	C3	0.1uF	Ceramic Capacitor; 100V;X7R;0603;	0603	muRata	GRM188R72A104KA35D
3	C4, C7, C8	0.1uF	Ceramic Capacitor; 16V;X7R;0603	0603	muRata	GRM188R71C104KA01D
2	C5, C6	22uF	Ceramic Capacitor; 16V;X7R;1210	1210	muRata	GRM32ER71C226KE18L
1	C9	39pF	Ceramic Capacitor; 50V;C0G;0603	0603	muRata	GRM1885C1H390JA01
1	C11	1uF	Ceramic Capacitor; 16V;X7R;0603;	0603	muRata	GRM188R71C105KA12D
1	C12	10nF	Ceramic Capacitor; 50V;X7R;0603;	0603	muRata	GRM188R71H103KA01D
4	C10, C13, C14, C15	NS				
1	L1	33uH	Inductor;33uH; 110mohm;1.55A	SMD	TDK	CLF7045T-330M-H
1	R1	1M	Film Resistor;5%;	0603	Yageo	RC0603JR-071ML
6	R3, R8, R10 R11,R12,R14	0	Film Resistor;5%;	0603	Yageo	RC0603JR-070RL
1	R4	10	Film Resistor;5%;	0603	Yageo	RC0603JR-0710RL
1	R6	1.2M	Film Resistor;1%;	0603	Yageo	RC0603FR-071M2L
1	R7	510K	Film Resistor;1%;	0603	Yageo	RC0603FR-07510KL
2	R8, R13	100K	Film Resistor;1%;	0603	Yageo	RC0603FR-07100KL
1	R15	51K	Film Resistor;1%;	0603	Yageo	RC0603FR-0751KL
4	R2, R5, R6, R9	NS				
1	U1		Step-Down Converter	TSSOP 16-EP	MPS	MPQ2420GF

EVB TEST RESULTS

Performance waveforms are tested on the evaluation board.

DC-DC Converter

$V_{IN} = 12V$, $V_{OUT} = 3.3V$, $L = 33\mu H$, $C_{OUT} = 2 \times 22\mu F$, $T_A = +25^\circ C$, unless otherwise noted.

Efficiency vs. Load Current

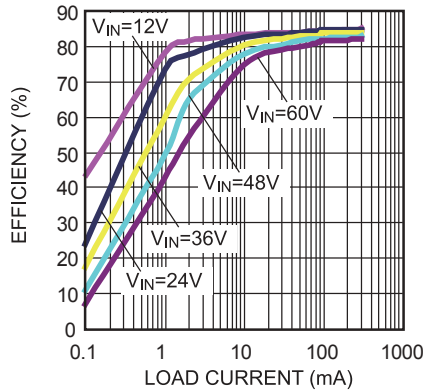

Load Regulation

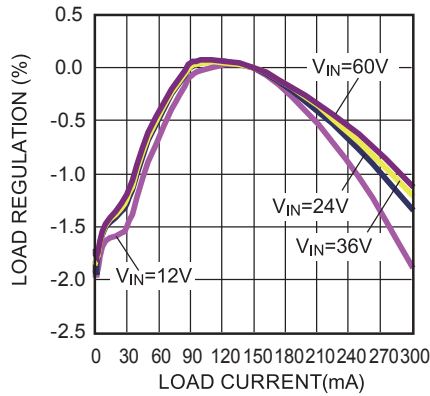

Line Regulation

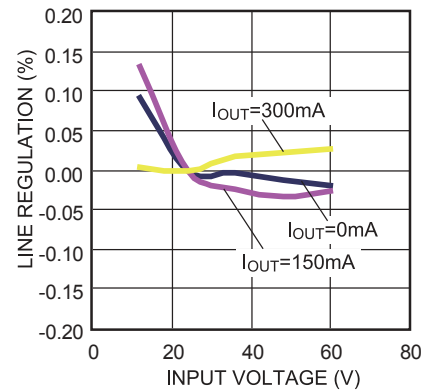

Steady State

$I_{OUT} = 0A$

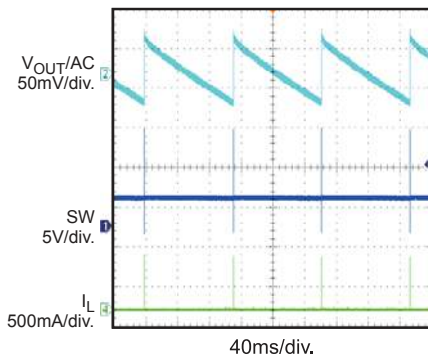

Steady State

$I_{OUT} = 0.3A$

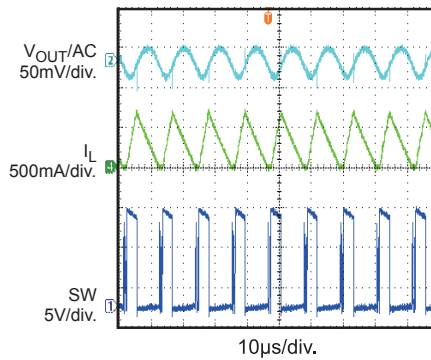

Start-Up through VIN

$I_{OUT} = 0A$

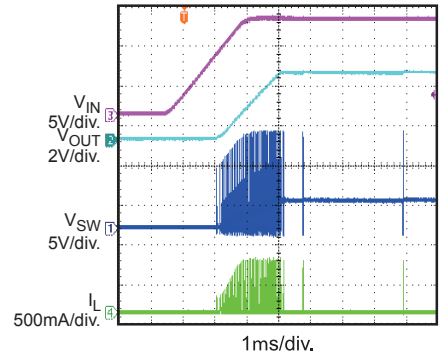

Startup through VIN

$I_{OUT} = 0.3A$

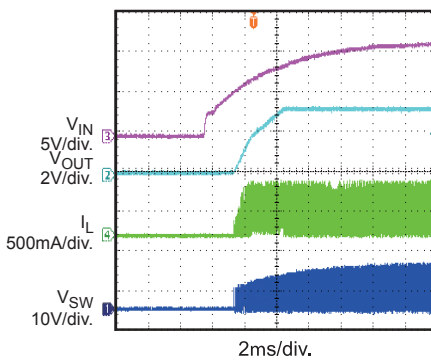

Shutdown through VIN

$I_{OUT} = 0A$

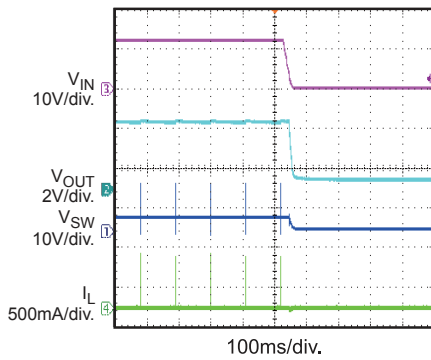

Shutdown through VIN

$I_{OUT} = 0.3A$

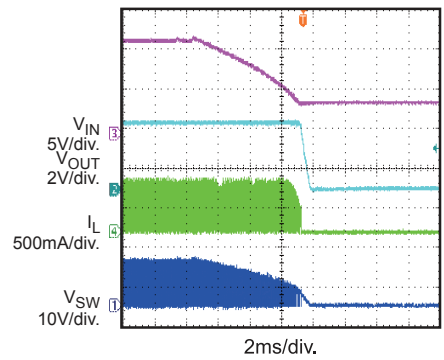

EVB TEST RESULTS (continued)

Performance waveforms are tested on the evaluation board.

DC-DC Converter

$V_{IN} = 12V$, $V_{OUT} = 3.3V$, $L = 33\mu H$, $C_{OUT} = 2 \times 22\mu F$, $T_A = +25^\circ C$, unless otherwise noted.

Startup Through EN

$I_{OUT} = 0A$

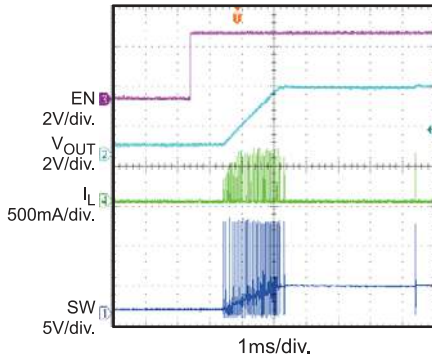

Startup Through EN

$I_{OUT} = 0.3A$

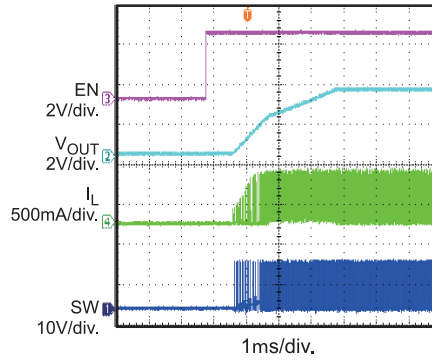

Shutdown Through EN

$I_{OUT} = 0A$

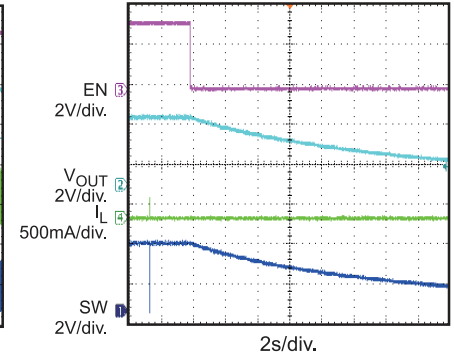

Shutdown Through EN

$I_{OUT} = 0.3A$

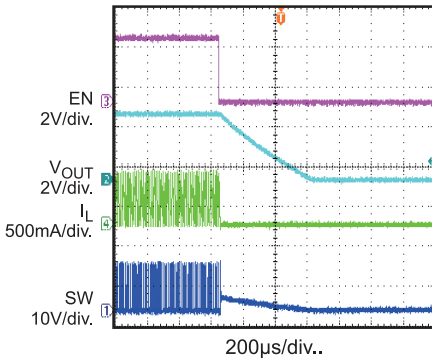

SCP Entry

$I_{OUT} = 0A$ to Short Circuit

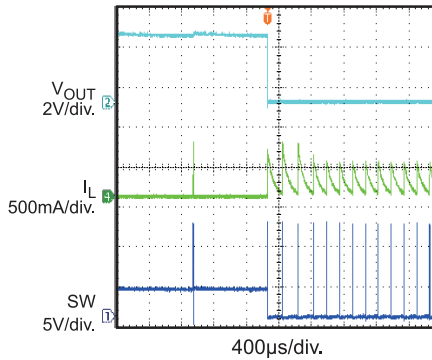

SCP Entry

$I_{OUT} = 0.3A$ to Short Circuit

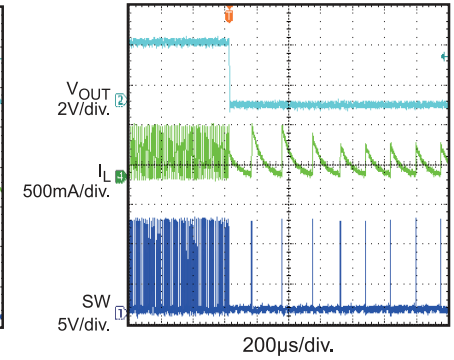

SCP Steady State

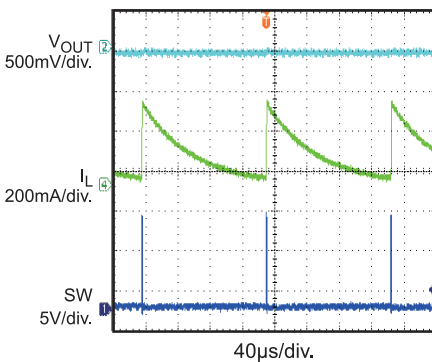

SCP Recovery

Short Circuit to $I_{OUT} = 0A$

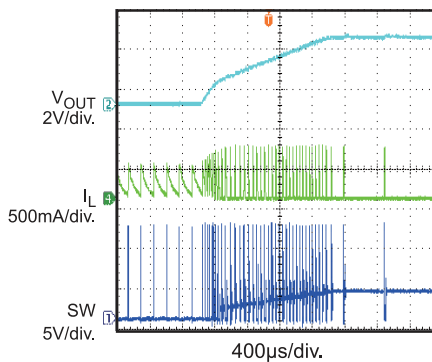

SCP Recovery

Short Circuit to $I_{OUT} = 0.3A$

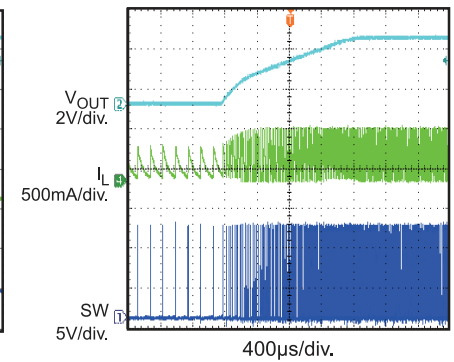

PRINTED CIRCUIT BOARD LAYOUT

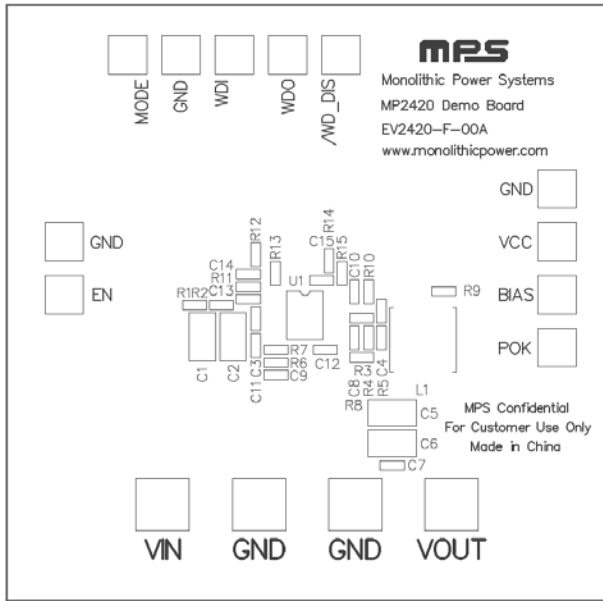

Figure 1: Top Silk Layer

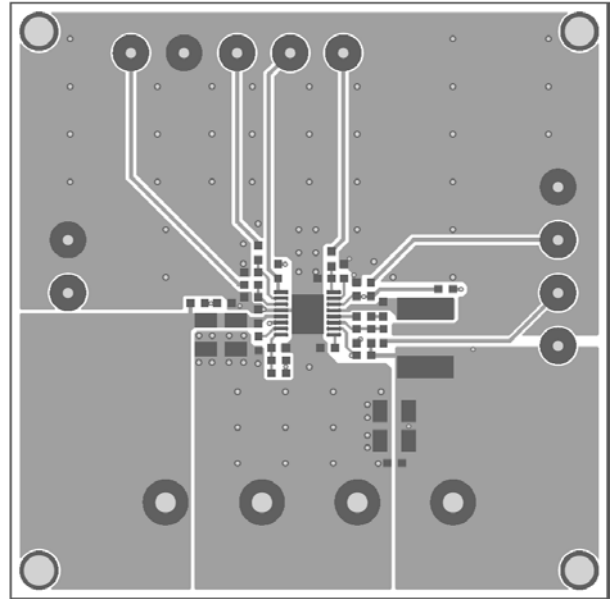

Figure 2: Top Layer

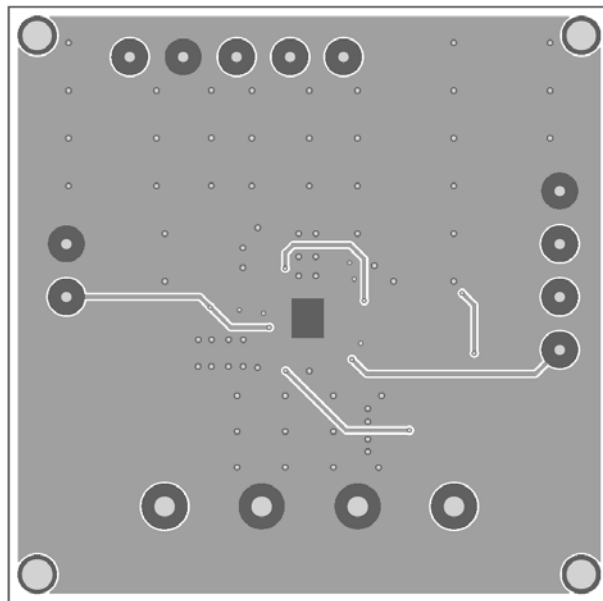

Figure 3: Bottom Layer

QUICK START GUIDE

1. Connect the positive and negative terminals of the load to the VOUT and GND pins respectively.
2. Preset the power supply output to between 4.5V to 75V, and then turn it off.
3. Connect the positive and negative terminals of the power supply output to the VIN and GND pins respectively.
4. Turn the power supply on. The MPQ2420GF will automatically startup.
5. To use the Enable function, apply a digital input to the EN pin. Drive EN higher than 1.55V to turn on the regulator, drive EN less than 1.2V to turn it off.
6. When floating EN pin, EN is pulled down to GND by an internal 3MΩ resistor, so it is disabled.
7. Use R6 and R7 to set the output voltage with $V_{FB}=1V$. For $R6=1.2M\Omega$, R7 can be determined by:

$$R7 = \frac{1.2}{V_{OUT} - 1} M\Omega$$

Follow the Application Information section in the device datasheet to recalculate the inductor and output capacitor values when output voltage is changed.

8. To use BIAS to power the internal regulator can improve efficiency. It is recommended to connect BIAS to a power supply in the range of 3.3V to 5.5V. The output voltage is a good choice for this power supply if it is in above range. If BIAS will be connected to an external power supply, remove R4 first, then connect R5 (0-10Ω). If BIAS is not used, it can be float.
9. To use the Watchdog function, set the VCC to 5V ($\pm 8\%$).
10. Drive the /WD-DIS pin higher than 3.2V to enable the watchdog function, set the pin lower than 0.8V to disable the watchdog. Float this pin to turn on the watchdog.
11. Connect the WDI and WDO pin to MCU to receive the trigger signal and output reset signal respectively.
12. Use R15 to set the time-out. For $R15=51k\Omega$, the period of timer T can be determined by:
$$T(\mu s) = 15.75 * R15(k\Omega) + 73.5$$
13. To choose the window mode, apply a digital input to the MODE pin, Drive MODE higher than 3.2V to go to long window mode, drive MODE less than 0.8V to work as the short window mode. Float this pin to make the watchdog work as the long window mode.

NOTICE: The information in this document is subject to change without notice. Please contact MPS for current specifications. Users should warrant and guarantee that third party Intellectual Property rights are not infringed upon when integrating MPS products into any application. MPS will not assume any legal responsibility for any said applications.