



Global LF Series Pure Sine Wave Inverter Charger User's Manual

PICOGLF12W12V120AL & PICOGLF25W12V120AL

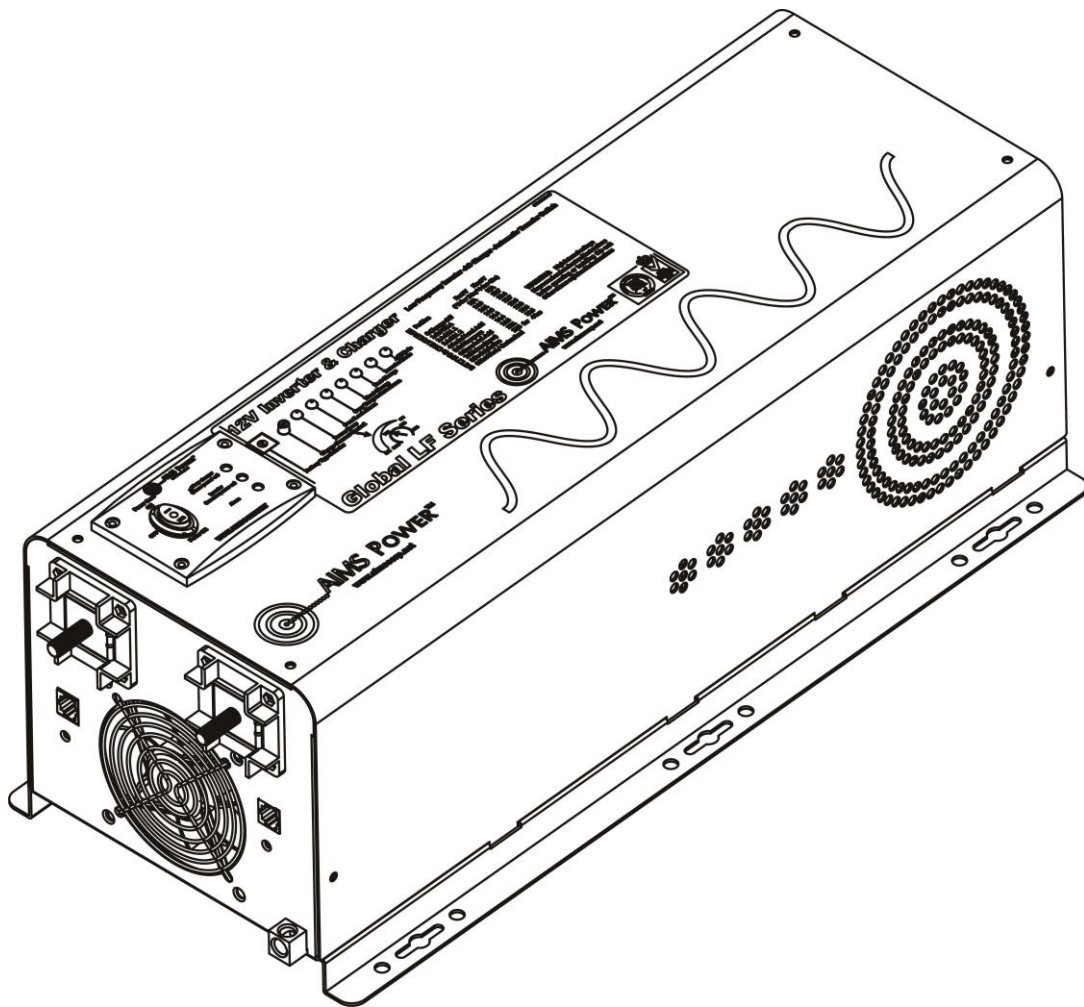
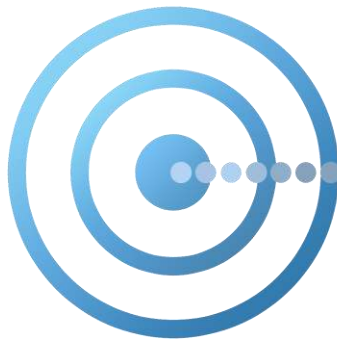

Table of Contents



AIMS POWER^T

www.aimscorp.net

.....	- 1 -
1. Important Safety Information.....	- 2 -
1-1. General Safety Precautions	- 2 -
1-2. Precautions When Working with Batteries	- 2 -
2. Introduction.....	- 4 -
2-1. General Information	- 4 -
2-2. Application	- 4 -
2-3. Mechanical Drawing	- 5 -
2-4. Features.....	- 7 -
2-5. Electrical Performance	- 7 -
2.5.1 Invert.....	- 7 -
2.5.2 AC Charger	- 7 -
2.5.3 Transfer.....	- 11 -
2.5.4 Auto Frequency Adjust.....	- 11 -
2.5.5 Power Saver.....	- 11 -
2.5.6 Protections.....	- 12 -
2.5.7 Remote Control	- 12 -
2.5.8 LED Indicator & RMT LCD.....	- 14 -
2.5.9 Audible Alarm	- 15 -
2.5.10 FAN Operation	- 15 -
2.5.11 Other Features	- 16 -
3. Installation	- 17 -
3-1. Location	- 17 -
3-2. DC Wiring.....	- 17 -
3-3. AC Wiring.....	- 17 -
3-4. Install Flange.....	- 19 -
4. Troubleshooting Guide.....	- 21 -
5. Warranty.....	- 23 -
Appendix 1.....	- 24 -

1. Important Safety Information



WARNING! Before using the Inverter, you need to read and save the safety instructions.

1-1. General Safety Precautions

1-1-1. Do not expose the Inverter to rain, snow, spray, bilge or dust. To reduce risk of hazard, do not cover or obstruct the ventilation openings. Do not install the Inverter in a zero-clearance compartment.

Overheating may result. Allow at least 12" of clearance around the inverter for air flow. Make sure that the air can circulate freely around the unit. A minimum air flow of 145CFM is required.

1-1-2. To avoid risk of fire and electronic shock, make sure that existing wiring is in good electrical condition and that the wire is not undersized. Do not operate the Inverter with damaged or substandard wiring.

1-1-3. This equipment contains components which may produce arcs and/or sparks. To prevent fire and/or explosion do not install in compartments containing batteries or flammable materials or in a location which require ignition protected equipment. This includes any space containing gasoline-powered machinery, fuel tanks, or joints, fittings, or other connection between components of the fuel system.

See Warranty for instructions on obtaining service.

1-1-4. Do not disassemble the Inverter/Charger. It contains no user-serviceable parts. Attempting to service the Inverter/Charger yourself may result in electrical shock or fire. Internal capacitors remain charged after all power is disconnected.

1-1-5. To reduce the risk of electrical shock, disconnect both AC and DC power from the Inverter/Charger before attempting any maintenance or cleaning. Turning off controls will not reduce this risk.

CAUTION: Equipment damage

The output side of the inverter's AC wiring should at no time be connected to public power or a generator. This condition is far worse than a short circuit. If the unit survives this condition, it will shut down until corrections are made.

Installation should ensure that the inverter's AC output is, at no time, connected to its AC input.

1-2. Precautions When Working with Batteries

1-2-1. If battery acid contacts skin or clothing immediately wash with soap and water. If acid enters eyes immediately rinse eyes with running cold water and seek immediate medical attention.

1-2-2. Never smoke or allow a sparks or flames in the vicinity of a battery.

1-2-3. Do not drop a metal tool on the battery. The resulting spark or short-circuit on the battery will cause an explosion.

1-2-4. Remove personal metal items such as rings, bracelets, necklaces, and watches when working with a battery. A battery produces a short-circuit current high enough to weld any metal objects and will cause a severe burn.

1-2-5. To reduce the risk of injury, charge only deep-cycle lead acid, lead antimony, lead calcium gel cell, absorbed mat, LIFEP04 lithium or NiCad/NiFe type rechargeable batteries. Other types of batteries may swell or burst causing personal injury and damage.

2. Introduction

2-1. General Information

The Global LF Series Pure Sine Wave Inverter charger product line is a combination of an inverter and battery charger with an AC auto-transfer switch into one complete system with a peak conversion efficiency of 88%.

It is packed with unique features and it is one of the most advanced inverter/chargers on the market today. It features power factor correction, sophisticated multi-stage charging and pure sine wave output with unprecedentedly high surge capability to meet demanding power needs of inductive loads without damaging the equipment.

When utility AC power cuts off (or falls out of acceptable range), the transfer relay is de-energized and the load is automatically transferred to Inverter mode. Once the qualified AC power is restored the relay is re-energized and the load is automatically reconnected to AC bypass mode.

The Global LF Series Inverter is equipped with a powerful smart charger.

The overload capacity is 300% of continuous output for up to 20 seconds to reliably support tools and equipment.

The Global LF Series Pure Sine Wave Inverter is suitable for renewable energy systems in work trucks, RV, marine and emergency appliances.

To get the most out of the power inverter, it must be operated and maintained properly. Please read the instructions in this manual before installing and operating.

2-2. Application

Power tools—circular saws, drills, grinders, sanders, buffers, weed and hedge trimmers, air compressors.

Office equipment – computers, printers, monitors, facsimile machines, scanners.

Household items – vacuum cleaners, fans, fluorescent and incandescent lights, shavers, sewing machines.

Kitchen appliances – coffee makers, blenders, ice makers, toasters.

Industrial equipment – metal halide lamp, high – pressure sodium lamp.

Home entertainment electronics – television, DVRs, video games, stereos, musical instruments, and satellite equipment.

2-3. Mechanical Drawing

PICOGLF 1250W Battery Side

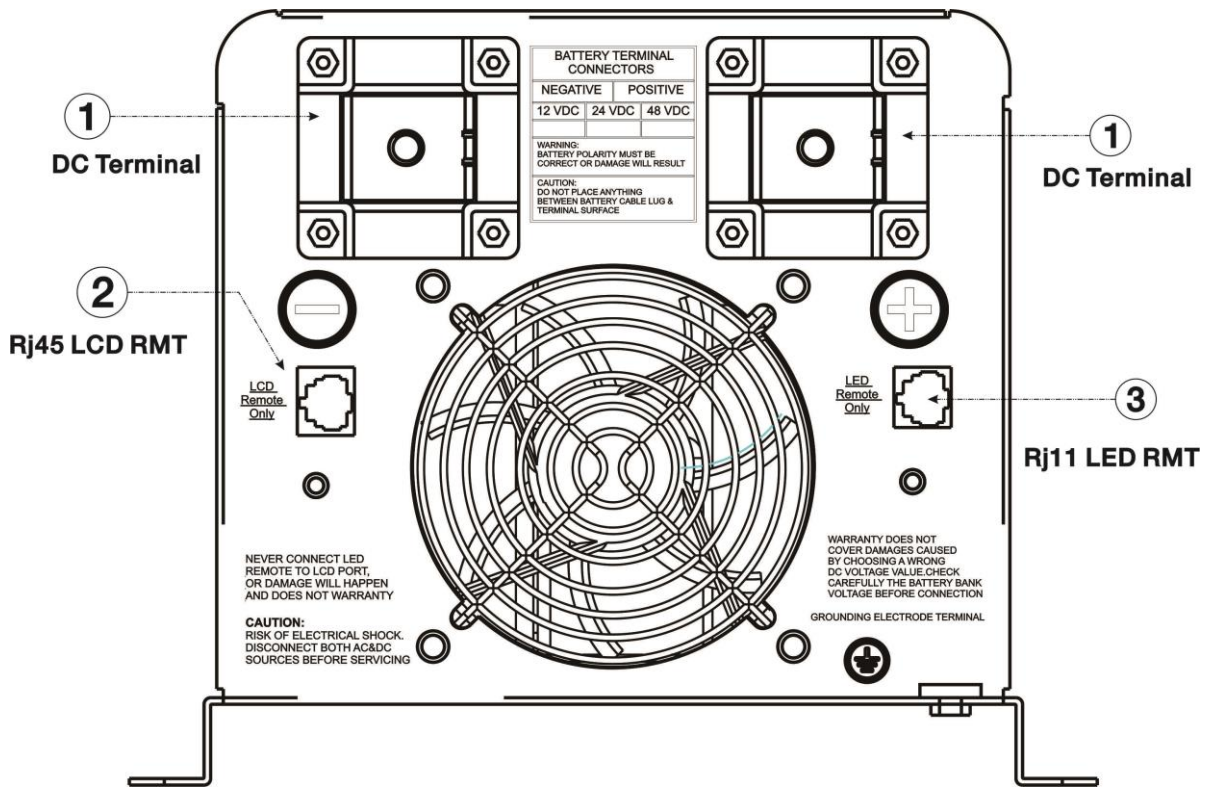

PICOGLF 1250W AC Side

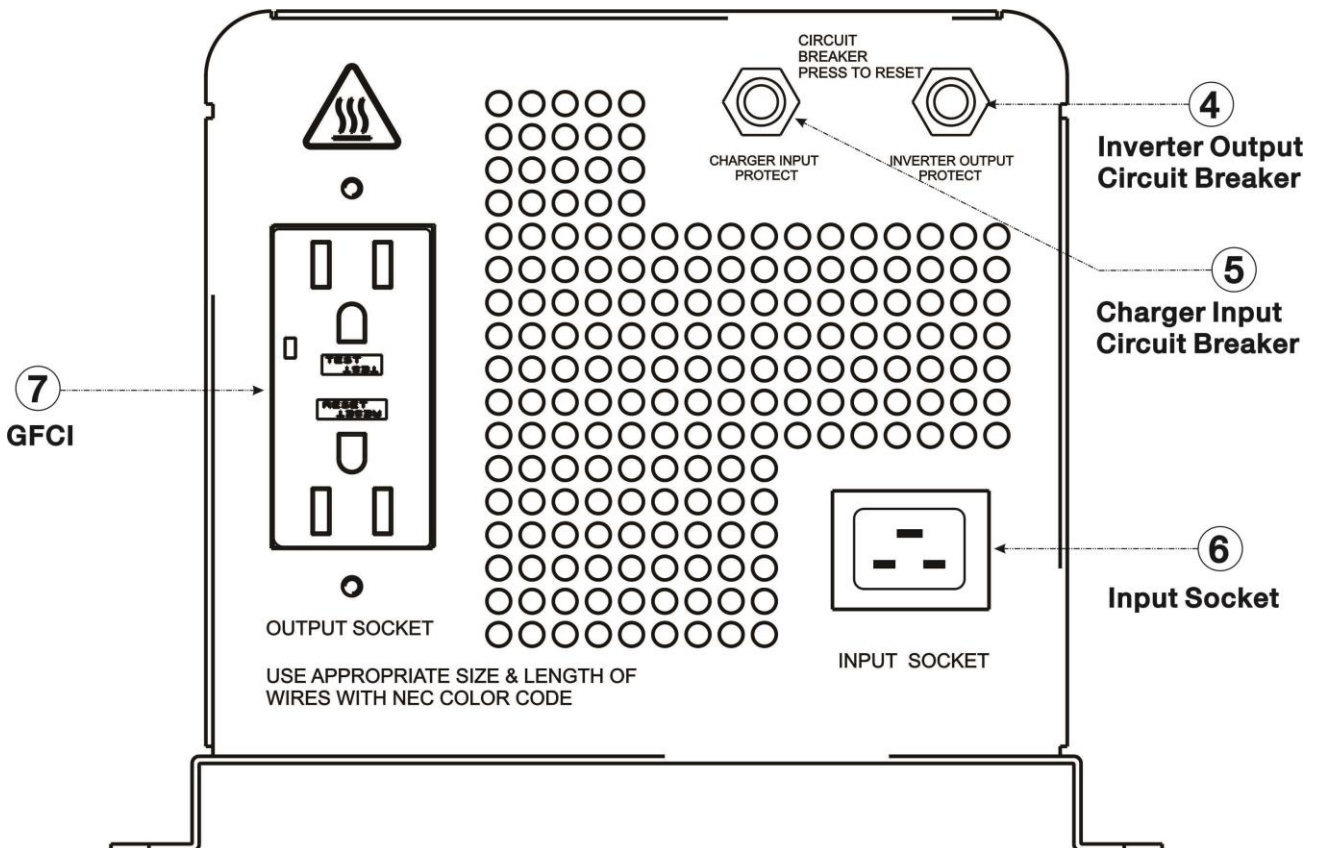

PICOGLF 2500W Battery Side

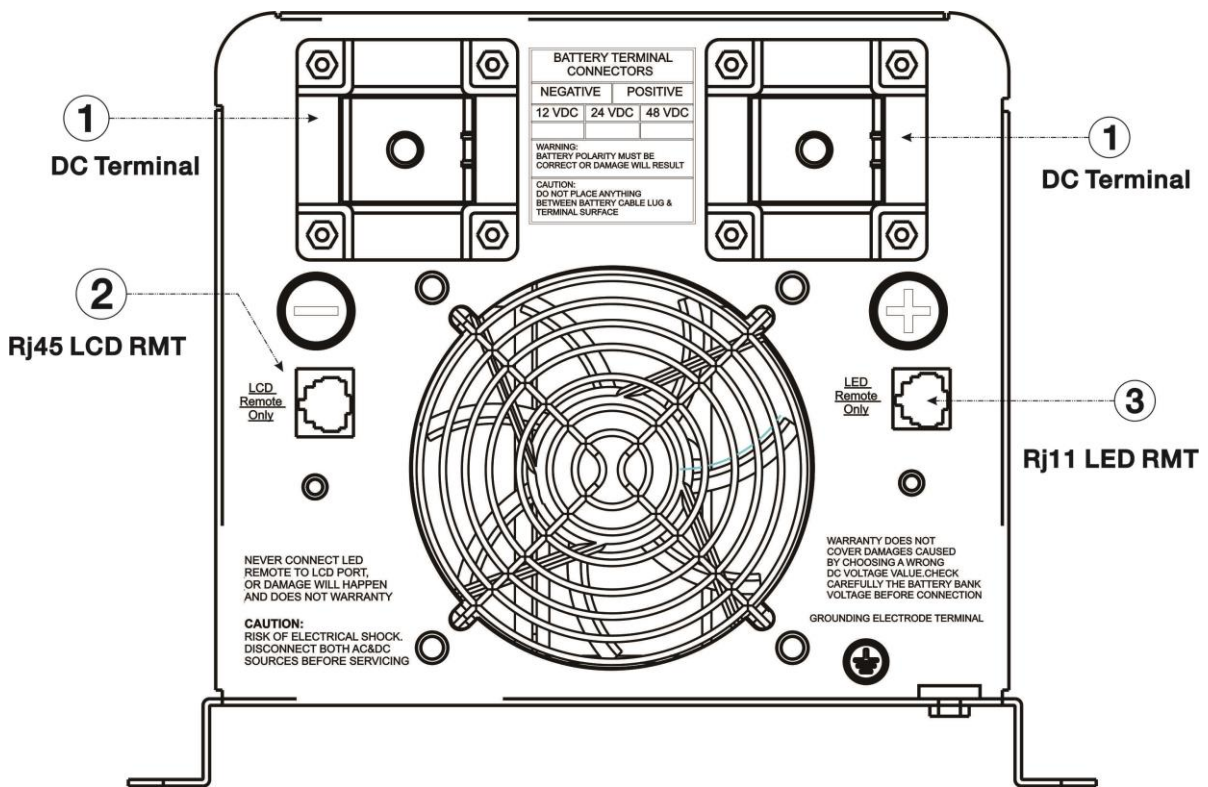

PICOGLF 2500W AC Side

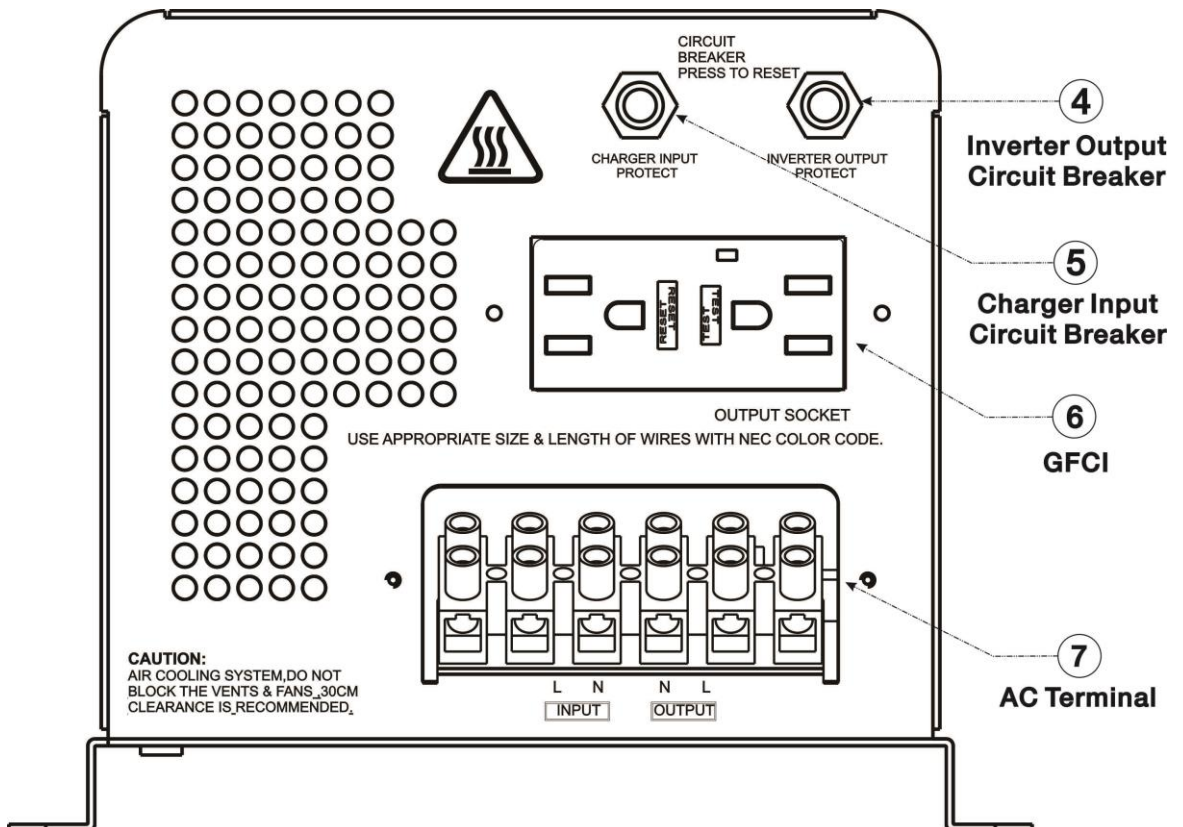

2-4. Features

High overload ability up to 300% of rated power (20 sec)
Low quiescent current, low power “Power Saving Mode” to conserve energy
4-step intelligent battery charger, PFC (Power Factor Correction) for charger
8 pre-set battery type selector switch plus de-sulphation for totally flat batteries
Powerful charge rate of up to 105Amp, selectable from 0%-100% (depends on model)
10 ms typical transfer time between battery and AC, guarantees power continuity
Smart remote control – Optional LED or LCD
15s delay before transfer when AC resumes, extra protection for loads when used with generator
Allows start up and through power with depleted batteries
30A/40A through put current ability
Multiple controlled cooling fans
Extensive protections against various harsh situations
13VDC battery recovery point, dedicated for renewable energy systems

2-5. Electrical Performance

2.5.1 Inverter

Topology

The Global LF inverter/charger is built according to the following topology.

Invert: Full Bridge Topology.

Charge: Isolated Boost Topology

Because of high efficiency Mosfets and 16bit, 4.9MHZ microprocessor and heavy transformers, it outputs PURE SINE WAVE AC with an average THD of 15% (min 5%, max 25%) depending of load connected and the battery voltage.

The peak efficiency of the Global LF series is 88%.

Overload Capacity

The Global LF series inverters have high overload capacities, making it ideal to handle demanding loads. 1 For $110% < \text{Load} < 125% (\pm 10%)$, no audible alarm for 14 minutes, beeps 0.5s every 1s in the 15th minute, and Fault(Turn off) after the 15th minute.

2 For $125% < \text{Load} < 150% (\pm 10%)$, beeps 0.5s every 1s and Fault(Turn off) after 1 minute. 3

For $300% \geq \text{Load} > 150% (\pm 10%)$, beeps 0.5s every 1s and Fault(Turn off) after 20s.

Caution:

After the inverter is switched on, it takes time for it to self-diagnose and ready to deliver full power. Hence, always switch on the load(s) after a few seconds of switching on the inverter. Avoid switching on the inverter with the load already switched on. This may prematurely trigger the overload protection. When a load is switched on, it may require initial higher power surge to start. Hence, if multiple loads are being powered, they should be switched on one by one so that the inverter is not overloaded by the higher starting surge if all the loads are switched on at once.

2.5.2 AC Charger

The Global LF Series inverter charger is equipped with an active PFC (Power Factor Corrected) multistage battery charger. The PFC feature is used to control the amount of power used to charge the batteries in order to obtain a power factor as close as possible to 1.

Unlike other inverters whose max charging current decreases according to the input AC voltage, the Global LF series inverter charger is able to output max current as long as the input AC voltage is in the range of 164-243VAC(95-127VAC for 120V model), and AC frequency is in the range of 48-54Hz(58-64Hz for 60Hz model).

The Global LF series inverter charger has a very rapid charge current available, and the max charge current can be adjusted from 0%-100% via a liner switch to the right of the battery type selector. This will be helpful if you are using our powerful charger on a small capacity battery bank. Fortunately, the liner switch can effectively reduce the max charging current to 20% of its peak.

Choosing "0" in the battery type selector will disable the charging function.



Caution:

Turn the charge current control switch gently to avoid breakage due to over-turning.

There are 3 charging stages:

Bulk Charging: (*fast charge LED solid*) this is the initial stage of charging. While Bulk Charging, the charger supplies the battery with controlled constant current. The charger will remain in Bulk charge until the Absorption charge voltage (determined by the Battery Type selection) is achieved.

A software timer will measure the time from A/C start until the battery charger reaches 0.3V below the boost voltage, then take this time as T_0 and $T_0 \times 10 = T_1$.

Absorb Charging: (*fast charge LED blinking*) This is the second charging stage when the fast charge LED is flashing and begins after the absorb voltage has been reached. Absorb Charging provides the batteries with a constant voltage and reduces the DC charging current in order to maintain the absorb voltage setting. In this period, the inverter will start a T_1 timer; the charger will keep the boost voltage in Boost CV mode until the T_1 timer has run out. Then drop the voltage down to the float voltage. The timer has a minimum time of 1 hour and a maximum time of 12 hours.

Float Charging: (*float charge LED solid*) The third charging stage occurs at the end of the Absorb Charging time. While Float charging, the charge voltage is reduced to the float charge voltage (determined by the Battery Type selection*). In this stage, the batteries are kept fully charged and ready if needed by the inverter.

If the A/C is reconnected or the battery voltage drops below 12Vdc/24Vdc, the charger will restart the above cycle.

If the charge maintains the float state for 10 days, the charger will deliberately reset the cycle to protect the battery.

Battery Charging Processes

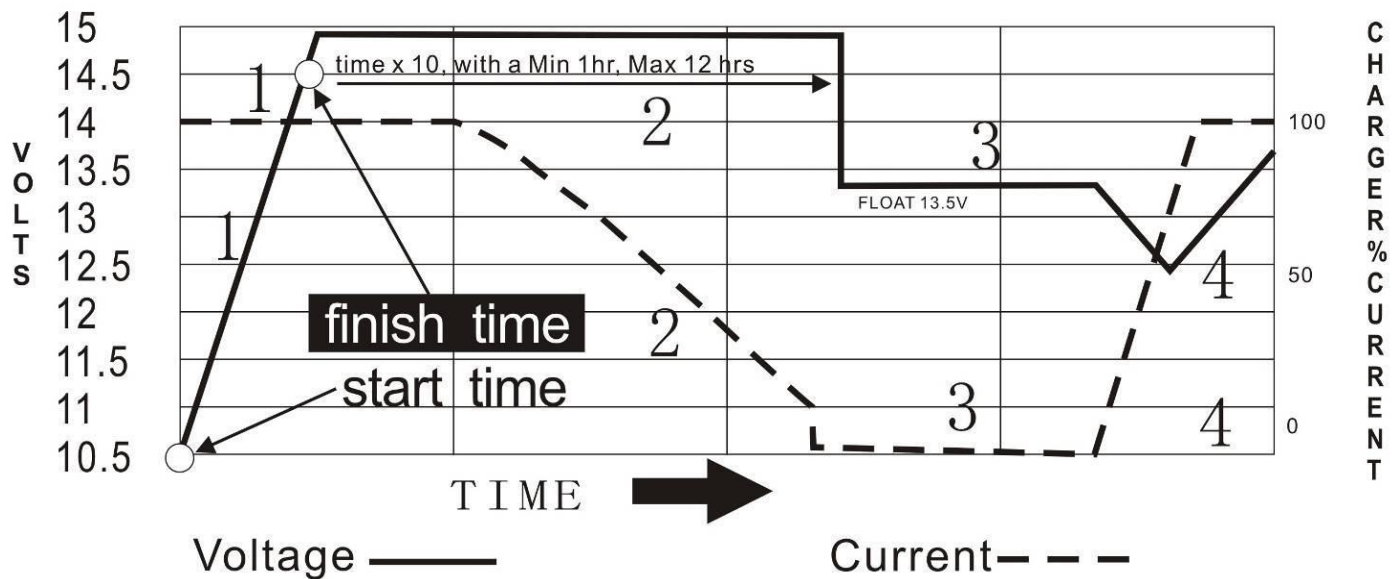

THE NEW BATTERY CHARGERS AND BOOSTERS OFFER THE FASTEST CHARGE RATE CURRENTLY AVAILABLE

STEP 1= Bulk Charge (Constant Current)
STEP 3= Float Voltage

STEP 2 = Absorption (Constant Voltage)
STEP 4 = RESET TO STEP 1

*2 FOR 24 VOLTS
*4 FOR 48 VOLTS

ADJUSTABLE TIME DEPENDING ON BATTERY BANK CAPACITY

Battery type selector

Switch setting	Description	Boost / Vdc	Float / Vdc
0	Charger Off		
1	Gel USA	14.0	13.7
2	AGM 1	14.1	13.4
3	AGM 2	14.6	13.7
4	Sealed lead acid / LIFEP04 lithium	14.4	13.6
5	Gel EURO	14.4	13.8
6	Open lead acid	14.8	13.3
7	Calcium	15.1	13.6
8	De-sulphation	15.5 (4 Hours then Off)	
9	Not used		

For 24V X 2, for 48V X 4. (X= multiply)

De-sulphation

The de-sulphation cycle (*switch position 8*) is a very dangerous setting if you do not know what you are doing. Before attempting to use this cycle you must clearly understand what it does and when and how you would use it.

What causes sulphation? This can occur with infrequent use of the batteries or if the batteries have been discharged low enough that they will not accept a charge. This cycle is a very high voltage charge cycle designed to try to break down the sulphated crust that is preventing the plates from taking a charge and allowing the plates to clean up and accept a charge once again.

Charging depleted batteries

The Global LF series inverter allows start up and through power with depleted batteries.

For 12VDC models: after the battery voltage goes below 10V and the power switch is kept in the "ON" position and the inverter stays connected to the battery and the battery voltage doesn't drop below 2V, the inverter will be able to charge the battery once qualified AC inputs are present.

Before the battery voltage goes below 9VDC, the charging can be activated when the switch is turned to "Off", then to "ON".

When the voltage goes below 9VDC, and you accidentally turn the switch to OFF or disconnect the inverter from the battery, the inverter will not be able to charge the battery once again, because the CPU loses memory during this process.

Charging current for each model

Model	Current
PICOGLF12W12V120AL	35+/-5A
PICOGLF25W12V120AL	85+/-5A

The charging capacity will peak charge rate in about 3 seconds. This may cause a generator to drop frequency, making the inverter transfer to battery mode.

It is recommended to gradually put the charging load on the generator by switching the charging switch from min to max. Together with the 15s switch delay our inverter gives the generator enough time to spin up. This will depend on the size of the generator and rate of charge.

2.5.3 Transfer

While in the Standby Mode, the AC input is continually monitored. Whenever AC power falls below the VAC Trip voltage (140 VAC, default setting for 230VAC,90VAC for 120VAC), the inverter automatically transfers back to the Invert Mode with minimum interruption to your appliances - as long as the inverter is turned on. The transfer from Standby mode to Inverter mode occurs in approximately 10 milliseconds. And it is the same time from Inverter mode to Standby mode.

Though it is not designed as a computer UPS system, this transfer time is usually fast enough to keep your equipment powered up.

There is a 15-second delay from the time the inverter senses that continuously qualified AC is present at the input terminals to when the transfer is made. This delay is built in to provide time for a generator to spin-up to a stable voltage and avoid relay chattering. The inverter will not transfer to generator until it has locked onto the generator's output. This delay is also designed to avoid frequent switching when input utility is unstable.

2.5.4 Auto Frequency Adjust

The factory default configuration for inverters sold in American market is 60Hz.

If the output frequency needs to be changed this is done by putting in a valid input Power Source to the inverter's input lines. Once the inverter validates the input, the output will automatically change.

NOTE: The inverter will output factory set frequency of 60Hz controlled with DIP switch #4 position1.

2.5.5 Power Saver

There are 2 different working statuses for our Global LF inverter: "Power On" and "Off".

When the power switch is in "Off" position, the inverter is powered off.

When the power switch is turned to either of "Power Save ON" or "Power ON", the inverter is powered on.

Power saver function is designed to conserve battery power when AC power is not or rarely required by the loads.

In this mode, the inverter pulses the AC output looking for an

AC load (i.e., electrical appliance). Whenever an AC load (greater than 50 watts) is turned on, the inverter recognizes the need for power and automatically starts inverting and output goes to full voltage. When there is no load (or less than 50 watts) detected, the inverter automatically goes back into search mode to minimize energy consumption from the battery bank.

In "Power save ON" mode, the inverter will draw power mainly in sensing moments, thus the idle consumption is significantly reduced.

The inverter will detect a load for 250ms every 3 seconds.

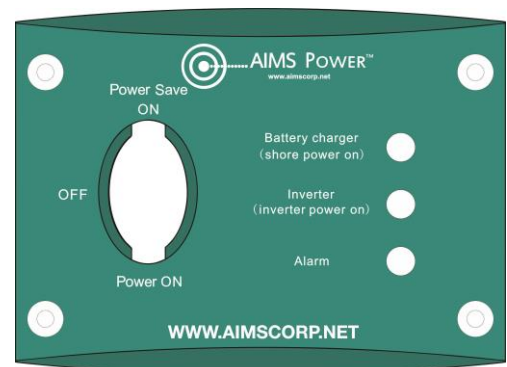



Note: The minimum power of a load to take inverter out of sleep mode (Power Saver On) is 50 Watts.

The Global LF Series is designed with extraordinarily low idle power consumption which is only a mere 0.8-1.8% of its rated power.

When in the search sense mode, the green power LED will blink and the inverter will make a ticking sound. At full output voltage, the green power LED will light steadily and the inverter will make a steady humming sound. When the inverter is used as an “uninterruptible” power supply the search sense mode or “Power Saver On” function should be defeated.

Exceptions

Some devices when scanned by the load sensor cannot be detected. Small fluorescent lights are the most common example. (Try altering the plug polarity by turning the plug over.) Some computers and sophisticated electronics have power supplies that do not present a load until line voltage is available. When this occurs, each unit waits for the other to begin. To drive these loads either a small companion load must be used to bring the inverter out of its search mode, or the inverter may be programmed to remain at full output voltage (Power On mode).

2.5.6 Protections

The Global LF series inverter is equipped with extensive protections against various harsh situations/faults. These protections include:

- AC Input over voltage protection/AC Input low voltage protection
- Low battery alarm/High battery alarm
- Over temperature protection/Over load protection
- Short Circuit protection (1s after fault)
- Back feeding protection

When Over temperature /Over load occur, after the fault is cleared, the master switch has to be reset to restart the inverter.

The inverter will go to Over temp protection when the heat sink temp. $\geq 105^{\circ}\text{C}$ (221°F), and go to Fault (shutdown Output) after 30 seconds. The switch has to be reset to activate the inverter.

The Global LF series Inverter has back feeding protection which avoids presenting an AC voltage on the AC input terminal in Invert mode.

After the reason for the fault is cleared, the inverter has to be reset to start working.

2.5.7 Remote Control

Apart from the switch panel on the front (or top) of the inverter, an extra switch panel connected to the RJ11 or RJ45 port at the DC side of the inverter thru a standard telephone cable can also control the operation of the inverter (sold separately Part # REMOTELF or REMOTELFLED).

If an extra switch panel is connected to the inverter via “remote control port”, together with the panel on the inverter case, the two panels will be connected and operated in parallel.

Whichever switches first from “OFF” to “Power ON” or “Power saver on”, it will power the inverter on.

If the commands from the two panels conflict, the inverter will operate according to the following priority:

Power saver on > Power ON > Power off

Only when both panels are turned to the “OFF” position, will the inverter be powered off.

The Max length of the cable is 10 meters.

12V Inverter & Charger

612-00388-00

Low Frequency Inverter -AC Charger -Automatic Transfer Switch

Battery Type Selector
 Charge Current Control
 Power Saver
 Over Load Alarm
 Over Temperature Alarm
 Float Charge
 Fast Charge
 Inverter Mode
 AC Mode

BATT. TYPE & CHG. VOLTAGE	Position	Fast V	Float V
0.Charge Off		N/A	N/A
1.Gel U.S.A		14.0	13.7
2.A.G.M. 1		14.1	13.4
3.A.G.M. 2		14.6	13.7
4.Sealed Lead Acid		14.4	13.6
5.Gel European		14.4	13.8
6.Open Lead Acid		14.8	13.8
7.Calcium (Open)		15.1	13.6
8.De Sulphation		15.5	for 4 hrs
9.Not Used / Customized			

WARNING: High internal voltage
 Please read and understand instructions
 before operating or installing this unit
 Other alarms explained in instructions

Global LF Series

AIMS POWER™
www.aimscorp.net

SHORE POWER ON	GREEN LED lit in AC Mode
INVERTER ON	GREEN LED lit in Inverter Mode
FAST CHARGE	Yellow LED lit in Fast Charging Mode
FLOAT CHARGE	GREEN LED lit in Float Charging Mode
OVER TEMP TRIP	RED LED lit in Over Temperature
OVER LOAD TRIP	RED LED lit in Over Load
POWER SAVER ON	GREEN LED lit in Power Saver Mode (Power Saver Load \leq 25W)

WARNING

Never cut the telephone cable when the cable is attached to inverter and battery is connected to the inverter. Even if the inverter is turned off, it will damage the remote PCB inside if the cable is short circuited during cutting.

2.5.8 LED Indicator & RMT LCD

The Remote LCD will display the following content:

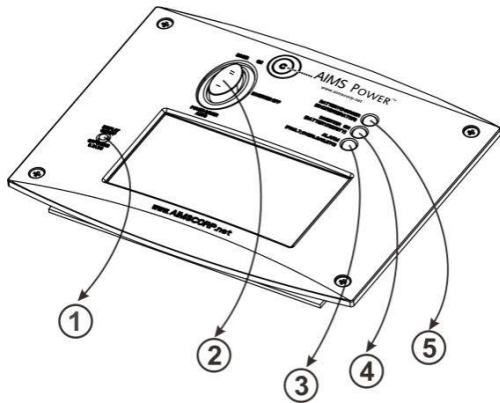

Function Description Drawing

- ① Display ON&OFF
- ② Power Switch ON&OFF
"="INVERTER ON "-"POWER SAVER AUTO
- ③ Alarm LED
- ④ Inverter LED
- ⑤ Battery Charger LED

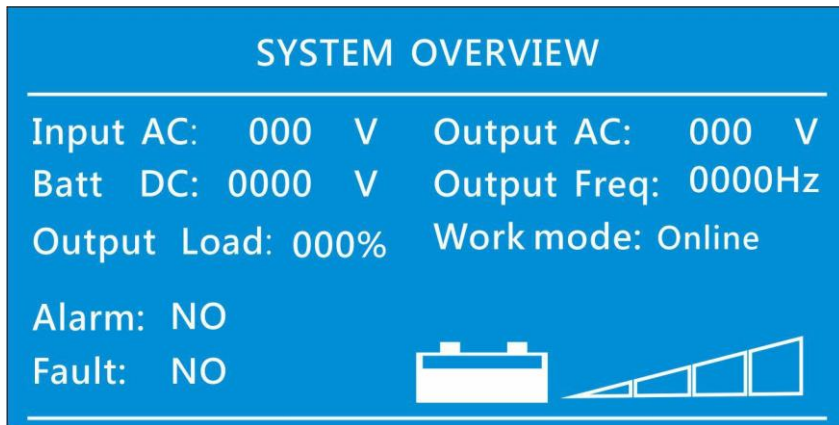

Greeting message of “Welcome to AIMS POWER”

AC Status & Input Voltage

“AC: abnormal” is displayed when AC input is not qualified.

Output Voltage/Frequency and Output Current (in percentage) in Inverter mode
Battery voltage

Note:

When the inverter is in Battery Priority mode, finishes a complete charging cycle and switches to inverter mode “AC: abnormal” will be displayed.

In AC mode, the LCD will not display the status of the AC load.

2.5.9 Audible Alarm

Battery Voltage Low	Inverter green LED lit, and the buzzer beeps 0.5s every 5s.
Battery Voltage High	Inverter green LED lit, and the buzzer beeps 0.5s every 1s and Fault after 60s.
Invert Mode Over-Load	(1) $110% < \text{load} < 125% (\pm 10\%)$, No audible alarm in 14 minutes, Beeps 0.5s every 1s in 15 th minute and Fault after 15 minutes; (2) $125% < \text{load} < 150% (\pm 10\%)$, Beeps 0.5s every 1s and Fault after 60s; (3) $\text{Load} > 150% (\pm 10\%)$, Beeps 0.5s every 1s and Fault after 20s;
Over Temperature	Heat sink temp. $\geq 105^{\circ}\text{C} (221^{\circ}\text{F})$, Over temp red LED Lighting, beeps 0.5s every 1s;

2.5.10 FAN Operation

For 1-3KW models, there is one multiple controlled DC fan which starts to work according to the below logic.

The Operation of the DC fan at the DC terminal side is controlled by the following logic:

Condition	Enter Condition	Leave condition	Speed
HEAT SINK	$T \leq 140^{\circ}\text{F}$	$T > 149^{\circ}\text{F}$	OFF
TEMPERATURE	$149^{\circ}\text{F} \leq T < 185^{\circ}\text{F}$	$T \leq 140^{\circ}\text{F}$ or $T \geq 185^{\circ}\text{F}$	50%
	$T > 185^{\circ}\text{F}$	$T \leq 176^{\circ}\text{F}$	100%
CHARGER CURRENT	$I \leq 15\%$	$I \geq 20\%$	OFF
	$20\% < I \leq 50\% \text{Max}$	$I \leq 15\%$ or $I > 50\% \text{Max}$	50%
	$I > 50\% \text{Max}$	$I \leq 40\% \text{Max}$	100%
LOAD Percentage (INV MODE)	Load < 30%	Load \geq 30%	OFF
	$30\% \leq \text{Load} < 50\%$	Load \leq 20% or Load \geq 50%	50%
	Load \geq 50%	Load \leq 40%	100%

Allow at least 6 inches of clearance around the inverter for air flow. Make sure that the air can circulate freely around the unit.

Fan noise level <60db at a distance of 3 feet.

2.5.11 Other Features

Battery voltage recovery start

After low battery voltage shut off (10V for 12V model or 20V for 24V model or 40V for 48V model), the inverter is able to restore operation after the battery voltage recovers to 13V/26V/52V (with power switch still in the “On” position). This function helps to save the users extra labor to reactivate the inverter when the low battery voltage returns to an acceptable range in renewable energy systems. The built in battery charger will automatically reactivate as soon as city/generator ac has been stable for 15 seconds.



WARNING

Never leave the loads unattended, some loads (like a Heater) may cause accidents in such cases. It is better to shut everything off after low voltage trip than to leave your load on, due to the risk of fire.

Conformal Coating

AIMS Power entire line of Global LF inverters have been processed with a conformal coating on the PCB, making it water, rust, and dust resistant as well as corrosion resistant.

While these units are designed to withstand corrosion from the salty air, they are not splash proof.

3. Installation

3-1. Location

Follow all the local regulations to install the inverter.

Please install the equipment in a location of Dry, Clean, Cool with good ventilation. Working temperature: 14°F to 104°F

Storage temperature: 40°F to 158°F Relative Humidity: 0% to 95%, non-condensing Cooling: Forced air

3-2. DC Wiring

It is recommended the battery bank be kept as close as possible to the inverter. The following is a suggested wiring option for 10 feet DC cable. If the application requires a longer run, use larger cable.

Power	DC Input voltage	Wire Gage
1.2KW	12V	4 AWG
2.5KW	12V	1/0 AWG



CAUTION

The torque rating range for DC terminal is 12.5NM-20.5NM, and the suggested torque rating is 17NM. Over torqueing may cause the bolt to break.



WARNING

In the event of reverse polarity the unit could be totally destroyed and warranty voided!

3-3. AC Wiring

We recommend using 10 to 6Awg wire to connect to the AC terminal block.

When in AC mode the AC input power will supply both the loads and AC charger, a thicker wire gauge for AC Input is required. Please consult a qualified electrician about the specific wire gauge required in terms of wire material and inverter power.

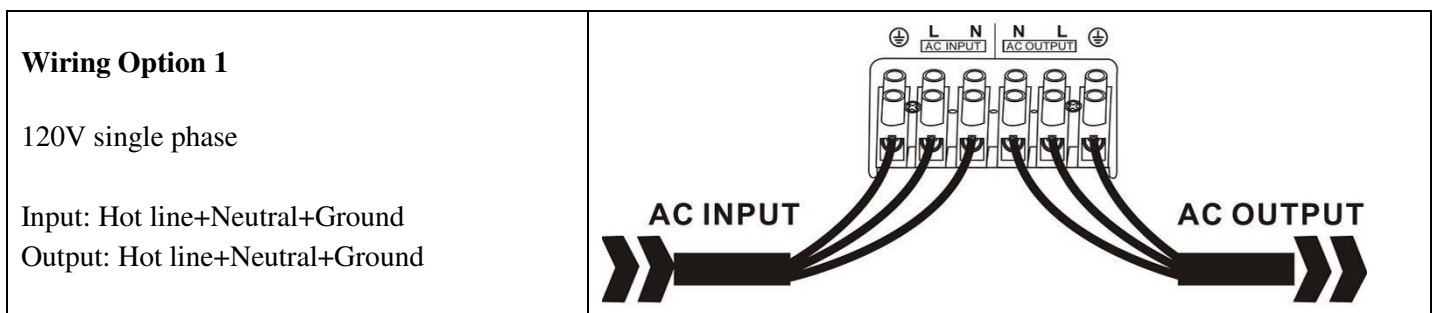

**WARNING**

For split phase models, AC input neutral is not required in wiring. Never Connect Input Neutral to Output Neutral. Damage will result which is not covered under warranty.

Always switch on the inverter before plugging in any appliance.

**WARNING**

The output voltage of this unit must never be connected in its input AC terminal, overload or damage may result.

Always switch on the inverter before plugging in any appliance.

3-4. Install Flange

<p style="text-align: center;">Frame 1</p>	<p>1250W</p>
<p style="text-align: center;">Frame 2</p>	<p>2500W</p>

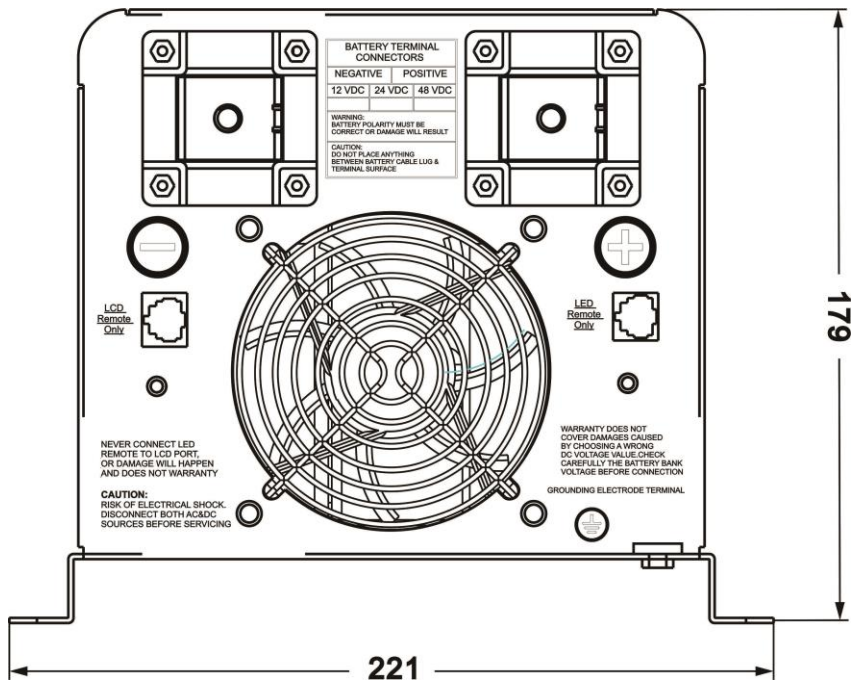

Side View

4. Troubleshooting Guide

Troubleshooting contains information about how to troubleshoot possible error conditions while using the Global LF Inverter & Charger.

The following chart is designed to help you quickly pinpoint the most common inverter failures.

Indicator and Buzzer

Status	Item	Indicator on top cover							LED on Remote Switch			Buzzer
		SHORE POWER ON	INVERTER ON	FAST CHG	FLOAT CHG	OVER TEMP TRIP	OVER LOAD TRIP	POWER SAVER ON	BATT CHG	INVERTER	Alarm	
Line Mode	CC	√	×	√	×	×	×	×	√	×	×	×
	CV	√	×	√, blink	×	×	×	×	√	×	×	×
	Float	√	×	×	√	×	×	×	√	×	×	×
	Standby	√	×	×	×	×	×	×	×	×	×	×
Inverter Mode	Inverter On	×	√	×	×	×	×	×	×	√	×	×
	Power Saver	×	×	×	×	×	×	√	×	×	×	×
Inverter Mode	Battery Low	×	√	×	×	×	×	×	×	√	√	Beep 0.5s every 5s
	Battery High	×	√	×	×	×	×	×	×	√	√	Beep 0.5s every 1s
	Overload On Invert Mode	×	√	×	×	×	√	×	×	√	√	Refer to “Audible alarm”
	Over-Temp On Invert Mode	×	√	×	×	√	×	×	×	√	√	Beep 0.5s every 1s
	Over-Temp On Line Mode	√	×	√	×	√	×	×	√	×	√	Beep 0.5s every 1s
	Over Charge	√	×	√	×	×	×	×	√	×	√	Beep 0.5s every 1s
Fault Mode	Fan Lock	×	×	×	×	×	×	×	×	×	×	Beep continuous
	Battery High	×	√	×	×	×	×	×	×	√	×	Beep continuous
	Inverter Mode Overload	×	×	×	×	×	√	×	×	×	×	Beep continuous
	Output Short	×	×	×	×	×	√	×	×	×	√	Beep continuous
	Over-Temp	×	×	×	×	√	×	×	×	×	×	Beep continuous
	Over Charge	×	×	√	×	×	×	×	√	×	×	Beep continuous
	Back Feed Short	×	×	×	×	×	×	×	×	×	×	Beep continuous

Symptom	Possible Cause	Recommended Solution
Inverter will not turn on during initial power up.	Batteries are not connected, loose battery-side connections. Low battery voltage.	Check the batteries and cable connections. Check DC fuse and breaker. Charge the battery.
No AC output voltage and no indicator lights ON.	Inverter has been manually transitioned to OFF mode.	Press the switch to Power saver on or Power saver off position.
AC output voltage is low and the inverter turns loads OFF in a short time.	Low battery.	Check the condition of the batteries and recharge if possible.
Charger is inoperative and unit will not accept AC.	AC voltage has dropped out-of-tolerance	Check the AC voltage for proper voltage and frequency.
Charger is supplying a lower charge rate.	Charger controls are improperly set. Low AC input voltage. Loose battery or AC input connections.	Refer to the section on adjusting the "Charger Rate". Source qualified AC power. Check all DC /AC connections.
Charger turns OFF while charging from a generator.	High AC input voltages from the generator.	Load the generator down with a heavy load. Turn the generator output voltage down.
Sensitive loads turn off temporarily when transferring between grid and inverting.	Inverter's Low voltage trip voltage may be too low to sustain certain loads.	Choose narrow AC voltage in the DIP switch, or Install a UPS if possible.
Noise from Transformer/case*	Applying specific loads such as hair drier	Remove the loads

The reason for the noise from transformer and/or case...

When in inverter mode sometimes the transformer and/or case of the inverter may vibrate and make noise. If the noise comes from transformer:

According to the characteristics of our inverter, there is one type of load which most likely may cause the transformer to rattle.

That is a half wave load. A load that uses only half a cycle of the power. This tends to cause an imbalance of the magnetic field of the transformer, reducing its rated working frequency from 20KHz to, say, maybe 15KHz (it varies according to different loads). In such a case the frequency of noise falls exactly into the range (200Hz-20KHz) that human ears can hear. The most common load is a hair drier.

If the noise comes from the case:

Normally when loaded with inductive loads, the magnetic field generated by the transformer keeps attracting or releasing the steel case at a specific frequency. This may also cause noise.

Reducing the load power or using an inverter with bigger capacity will normally solve this problem. The noise will not do any harm to the inverter or the loads.

5. Warranty

We offer a 1 year limited warranty.

The following cases are not covered under warranty.

1 DC reverse polarity.

The inverter is NOT designed with DC reverse polarity protection. A reverse polarity may severely damage the inverter.

2 Wrong AC wiring

3 Operation in a moist environment.

4 Operating with an undersized generator or generator with unqualified wave form.

AIMS Operating Corp., Inc. dba AIMS Power Warranty Instructions:

This product is designed using the most modern digital technology and under very strict quality control and testing guide lines. If, however you feel this product is not performing as it should, please contact us:

techsupport@aimscorp.net or (775)359-6703.

We will do our best to resolve your concerns. If the product needs repair or replacement, make sure to keep your receipt/invoice, as that will need to be sent back along with the package and RA# prepaid to AIMS. You have a full 1 year from date of purchase warranty.

This warranty is valid world-wide with the exception that freight and duty charges incurred outside the contiguous 48 United States will be prepaid by customer.

Except as provided above, AIMS makes no warranty of any kind, express or implied, including without limitation the implied warranties of merchantability and fitness for a particular purpose. In no event shall AIMS be liable for indirect, special or consequential damages. This warranty only applies to AIMS Power branded products. All other name brand products are warranted by and according to their respective manufacturer. Please do not attempt to return non-AIMS Power branded products to AIMS Power.

For additional products such as:

- Modified sine wave inverters
- Pure sine wave inverters
- Solar Charge Controllers
- On Grid Inverters
- Inverter Chargers and Automatic transfer switches
- Custom cut cables
- Batteries
- Solar Panels

Please visit our web site: www.aimscorp.net

To find out where to buy any of our products, you may also e-mail: sales@aimscorp.net or call (775)359-6703.

Appendix 1

Global Low Freq Series Inverter & AC Charger				
Electrical Specifications				
	Model	1250W	2500W	
Inverter Output	Continuous Output Power	1250W	2500W	
	Surge Rating(20s)	3750W	7500W	
	Output Waveform	Pure Sine wave/Same as input (Bypass mode)		
	Nominal Efficiency	>88%(Peak)		
	Line Mode Efficiency	>95%		
	Power Factor	0.9-1.0		
	Nominal Output Voltage rms	100-110-120Vac		
	Output Voltage Regulation	±10% RMS		
	Output Frequency	60Hz ±0.3Hz		
	Short Circuit Protection	Yes, Current Limit Function (Fault after 1sec)		
	Typical transfer Time	6-8ms 10ms(Max)		
	THD	< 10%		
DC Input	Nominal Input Voltage	12.0Vdc (*2 for 24Vdc, *4 for 48Vdc)		
	Minimum Start Voltage	10.0Vdc		
	Low Battery Alarm	10.5Vdc		
	Low Battery Trip	10.0Vdc		
	High Voltage Alarm & Fault	16.0Vdc		
	High DC Input Recovery	15.5Vdc		
	Low Battery voltage recover	13.0Vdc		
	Idle Consumption-Search Mode	< 50 W when Power Saver On		
Charge	Input Voltage Range	Narrow: 90~135VAC		
	Input Frequency Range	Narrow: 57-65±0.3Hz		
	Output Voltage	Depends on battery type		
	Charger Breaker Rating(120Vac)	15A	30A	
	Max Charge Rate	See specific charge rates in “2.5.2 AC Charger” section		
	Over Charge Protection	15.7V for 12Vdc (*2 for 24Vdc, *4 for 48Vdc)		
	Shutdown			
	Battery type	Fast Vdc	Float Vdc	
	Gel U.S.A	14.0	13.7	
	A.G.M 1	14.1	13.4	
	A.G.M 2	14.6	13.7	

	Sealed Lead Acid	14.4	13.6
	Gel Euro	14.4	13.8
	Open Lead Acid	14.8	13.3
	Calcium	15.1	13.6
	De-sulphation	15.5 for 4hrs	
	Remote Control	Yes. Optional	
Bypass & Protection	Input Voltage Waveform	Sine wave (Grid or Generator)	
	Nominal Voltage	120Vac	
	Low Voltage Trip	85V±4%	
	Low Voltage re engage	90V±4%	
	High Voltage Trip	135V±4%	
	High Voltage re engage	130V±4%	
	Max Input AC Voltage	150VAC	
	Nominal Input Frequency	60Hz (Auto detect)	
	Low Frequency Trip	Narrow:57±0.3Hz	
	Low Frequency re engage	Narrow: 58±0.3Hz	
	High Frequency Trip	Narrow: 65±0.3Hz	
	High Frequency re engage	Narrow: 64±0.3Hz	
	Output Short circuit protection	Circuit breaker	
Mechanical Specification	Bypass breaker rating (120Vac)	15A	30A
	Mounting	Wall/Ground mount	
Mechanical Specification	Inverter Dimensions(L*W*H)	14.25"x 8.7" x 7"	19.88" x 8.7" x 7.04"
	Inverter Weight	38 lb	46 lb
	Shipping Dimensions(L*W*H)	20.47" x 12.6" x 12.2"	26.4" x 12.6" x 12.2"
	Shipping Weight	42 lb	50 lb
	Display	Status LEDs	
	Standard Warranty	1 Year	

※Specifications in this manual are subject to change without prior notice

614-00059-00