

Pos. 1 Designate
Pin #1 Location

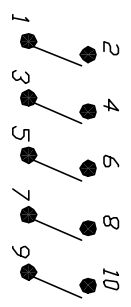

CIRCUIT 5 POSITION

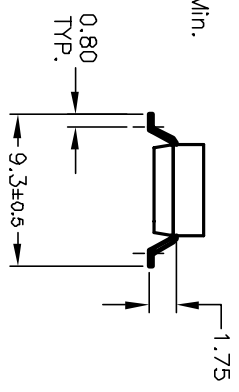
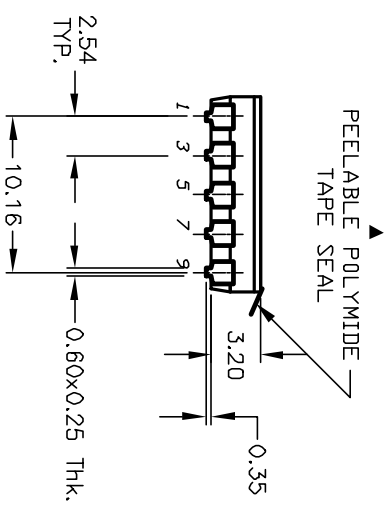
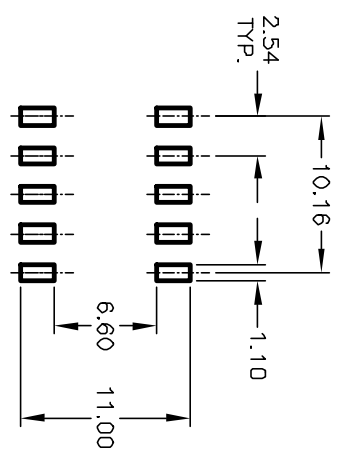

RECOMMENDED P.C.B. LAYOUT

E-SWITCH®

- NOTES:
1. ALL DIMENSIONS IN MM
 2. GENERAL TOLERANCE: X.X=±0.4
X.XX=±0.25
 3. TERM. NOS. FOR REFERENCE ONLY.
 4. CONTACT RATINGS:
25mA @24VDC. (SWITCH)
100mA @50VDC (CARRY)
 5. CONTACT MATERIAL:
CONTACTS: BRASS w/Gold Plate
TERMINALS: BRASS w/GOLD Plate
 6. PACKAGED: TAPE & REEL
WITH ALL POLES IN THE "OFF" POSITION.
{QTY 1000 PER REEL}
 7. TAPE SEAL FOR FLUX WASH.
 8. ▲ DESIGNATE MAJOR:

REV.	ECN No.	DESCRIPTION	DATE	CHKD
A	12277	RELEASED FOR PRODUCTION	7/1/02	CJB

TITLE	SCALE	DATE	DR	DWG	REV
KAJ05 TG GR (TAPE & REEL) LDW PROFILE W/TAPE SEAL	2:1	7/1/02	CJB	W825365	A

THE INFORMATION CONTAINED IN THIS DOCUMENT IS PROPRIETARY TO E-SWITCH AND IS NOT TO BE COPIED OR TRANSFERRED