

REVISONS		DATE	DWN	APVD
P	LTR	DESCRIPTION		
1		PRE-RELEASED	28JAN2003	KW JE
0		REVISED PER 0638-0595-03	16JAN06	KW JE

1. MOUNTING CLAMPS SOLD IN PAIRS, SCREWS NOT INCLUDED.

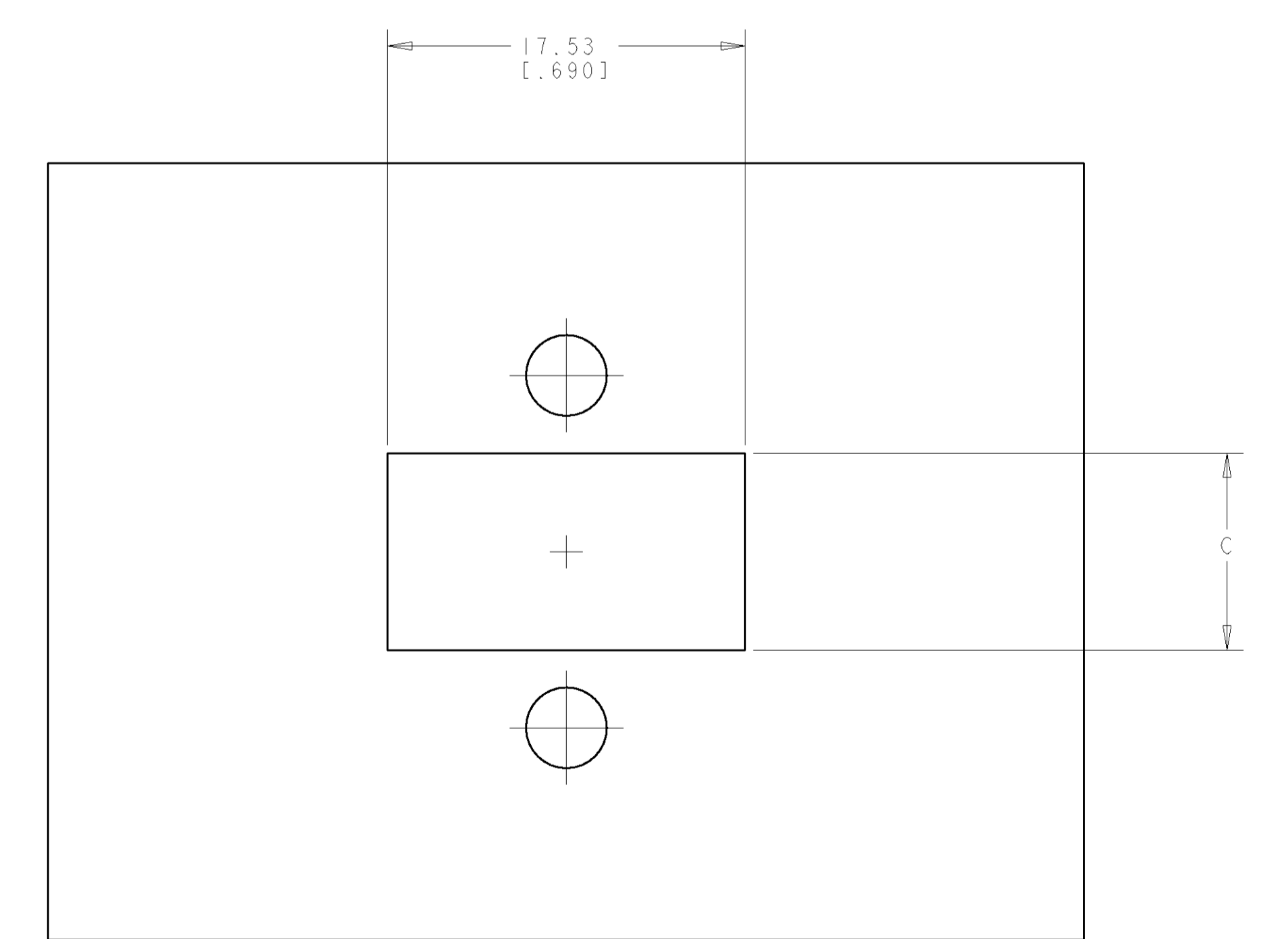

PANEL CUTOUT DIMENSIONS

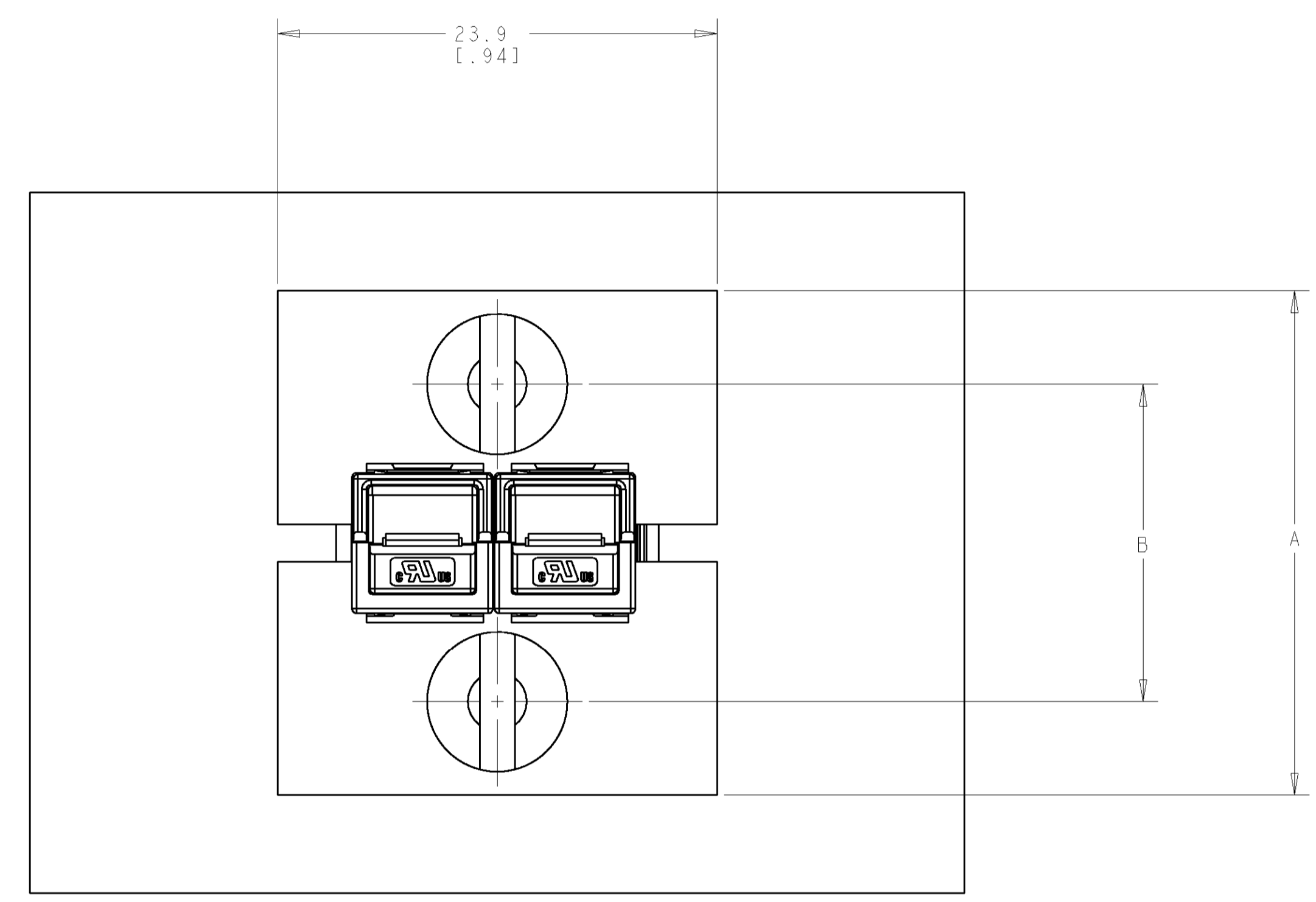
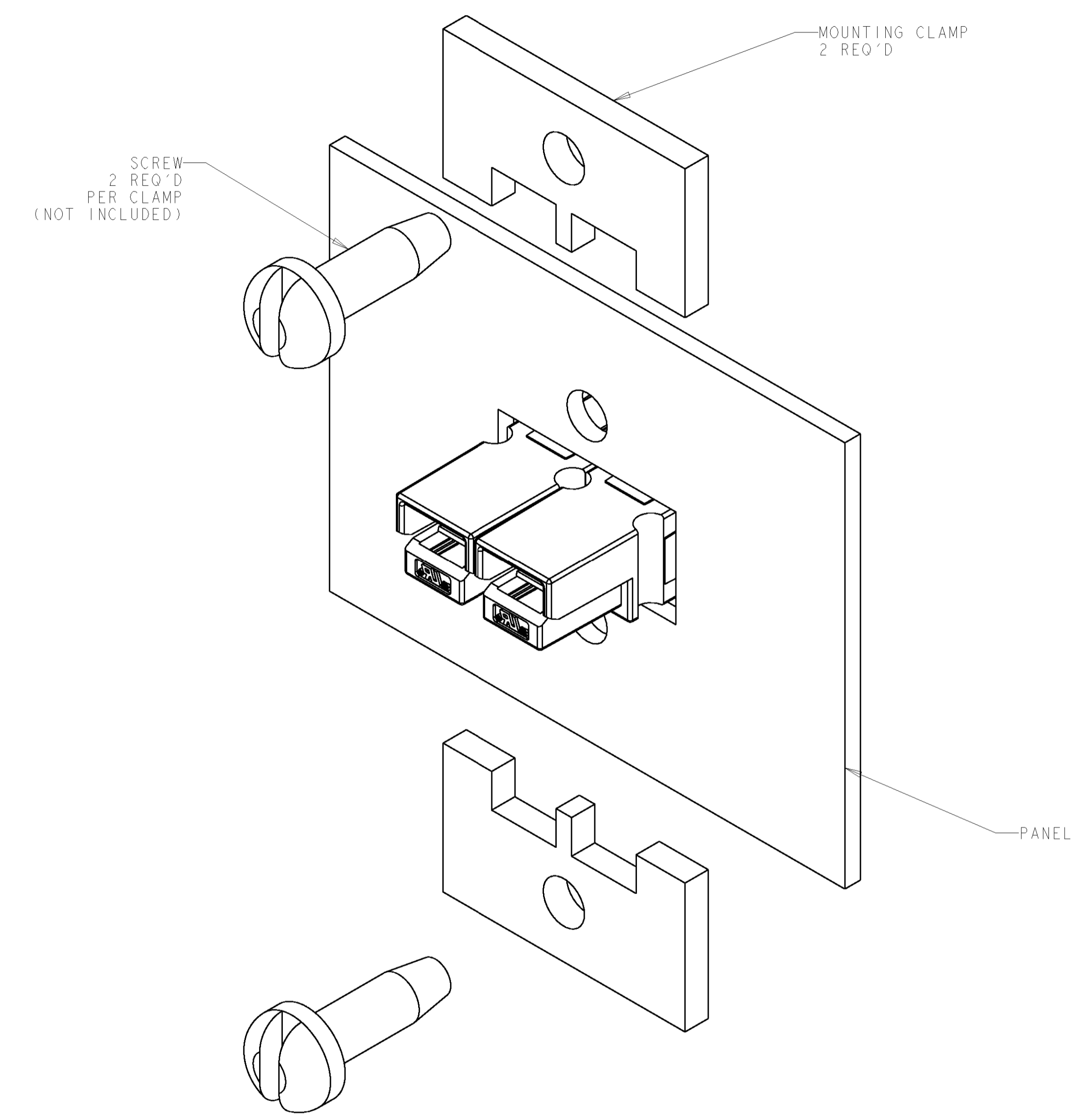

17.5 [0.69]	25.4 [1.00]	35.0 [1.38]	4
9.7 [0.38]	17.3 [0.68]	26.9 [1.06]	2
C	B	A	NO OF POLES

1 BOX	647766-2
1 PAIR	647766-1
QTY / UNIT OF MEASUREMENT	PART NUMBER

<small>THE INFORMATION CONTAINED HEREIN IS UNCLASSIFIED EXCEPT WHERE SHOWN OTHERWISE. IT IS THE PROPERTY OF TICO ELECTRONICS CORPORATION AND IS TO BE CONTROLLED AND DISTRIBUTED IN ACCORDANCE WITH THE COMPANY'S POLICY.</small>		DWN J. WHITAKER 28JAN2003 ENR J. ELLIS 28JAN2003 APVD J. ELLIS 28JAN2003	Tyco Electronics Harrisburg, PA 17105-3608
DIMENSIONS: mm [INCHES]	TOLERANCES UNLESS OTHERWISE SPECIFIED:	NAME AMP POWER SERIES PP15/45, MOUNTING CLAMP, 2 AND 4 POLE	RESTRICTED TO
0 PLC ± 1 PLC ±0.5 [0.02] 2 PLC ± 3 PLC ± 4 PLC ± ANGLES ± FINISH -	MATERIAL AL 1.52 [0.06] THK	PRODUCT SPEC APPLICATION SPEC WEIGHT CUSTOMER DRAWING	SIZE CAGE CODE DRAWING NO A1 00779 C=647766 SCALE 4:1 SHEET 1 OF 1 REV 0

