

ENVIRONMENTAL-D

D-subminiature Connectors



Positronic[®]
an Amphenol company

LOOK FOR OUR
NEW PRODUCTS!
NEW!

**WATER & DUST
INGRESS PROTECTION
NEMA 250-1991
MIL-STD 1344
IEC 60529**



Catalog C-006 Rev A4

www.connectpositronic.com

Connector Excellence®

Positronic Provides Complete Capability

Mission Statement
"To utilize product flexibility and application assistance to present quality interconnect solutions which represent value to customers worldwide."

Experience

- Founded in **1966**
- **Involvement** in the development of international connector specifications through EIA®, IEC and ISO as well as PICMG®.
- Introduction of new and **unique connector products** to the electronics industry.
- Patent holder for many **unique connector features and manufacturing techniques**.
- **Vertically integrated** manufacturing – raw materials to finished connectors.

Technology

- **Expertise** with solid machined contacts provides a variety of high reliability connectors including high current density power connectors.
- Quality Assurance lab is **capable of testing** to IEC, EIA, UL, CUL, military and customer-specified requirements.
- **In-house design and development** of connectors based on market need or individual customer requirements.
- **Internal manufacturing capabilities** include automatic precision contact machining, injection molding, stamping, plating operations and connector assembly.
- **Manufacturing locations** in southwest Missouri, U.S.A. (headquarters); Puerto Rico, France, China, Singapore, and India. Total square footage: 407,441.



Support

- **Quality Systems:** Select locations qualified to ISO 9001, ISO 14001, AS9100, MIL-STD-790 and customer "dock to stock" programs. Applicable products qualified to MIL-DTL-24308, SAE AS39029, DSCC 85039, MIL-DTL-28748, Space D32, GSFC S-311-P-4 and GSFC S-311-P-10.
- Compliance to a variety of international and customer specific **environmental requirements**.
- Large **in-house inventory** of finished connectors. Customer specific **stocking programs**.
- Factory direct **technical sales support** in major cities worldwide.
- **One-on-one customer support** from worldwide factory locations.
- World class **web site**.
- **Value-added solutions** and willingness to **develop custom products** with reasonable price and delivery.

Regional Headquarters

Springfield, MO



Auch, France



Singapore



Products described within this catalog may be protected by one or more of the following US patents:

- #4,900,261 #5,255,580 #5,329,697
- #6,260,268 #6,835,079 #7,115,002

Patented in Canada, 1992 Other Patents Pending

Positronic Industries' **FEDERAL SUPPLY CODE** (Cage Code)
 FOR MANUFACTURERS is **28198**

Unless otherwise specified, **dimensional tolerances** are:

- 1) ±0.001 inches [0.03 mm] for male contact mating diameters.
- 2) ±0.003 inches [0.08 mm] for contact termination diameters.
- 3) ±0.005 inches [0.13 mm] for all other diameters.
- 4) ±0.015 inches [0.38 mm] for all other dimensions.

POSITRONIC® IS AN ITAR REGISTERED COMPANY

Information in this catalog is proprietary to Positronic and its subsidiaries. Positronic believes the data contained herein to be reliable. Since the technical information is given free of charge, the user employs such information at his own discretion and risk. Positronic Industries assumes no responsibility for results obtained or damages incurred from use of such information in whole or in part. The following trademarks are registered to Positronic Industries, Inc. in the United States and many other countries: Positronic Industries, Inc.®, Positronic®, Connector Excellence®, P+ logo®, PosiBand®, PosiShop®, Positronic Global Connector Solutions®, Global Connector Solutions®. The color blue as it appears on various connectors is a trademark of Positronic Industries, Inc., Registered in U.S. Patent and Trademark Office.



WIN-D STANDARD DENSITY SEALED D-SUBMINIATURE, IMPROVED UNIBODY DESIGN

The WD Unibody design provides a one piece connector body providing superior sealing performance. Solder cup, straight and right angle (90°) printed board mount terminations. Five connector variants, 9-50 contacts. Size 20 contacts, professional level performance, IP67.



WIN-DD HIGH DENSITY SEALED D-SUBMINIATURE, IMPROVED UNIBODY DESIGN

The WDD Unibody design provides a one piece connector body providing superior sealing performance. Solder cup, straight and right angle (90°) printed board mount terminations. Three connector variants, 15, 26 and 44 contacts, with more variants being tooled. Size 22 contacts, professional level performance, IP67.



WIN-D STANDARD DENSITY SEALED D-SUBMINIATURE, LEGACY DESIGN

The WD legacy design uses high quality material and manufacturing techniques to provide sealing. Solder cup, straight and right angle (90°) printed board mount terminations. Two connector variants: 25 (male) and 50 (male) contacts. All other standard density connector variants are supplied as Unibody, see description above. Size 20 contacts, professional level performance, IP67.



WIN-DD HIGH DENSITY SEALED D-SUBMINIATURE, LEGACY DESIGN

The WDD legacy design uses high quality material and manufacturing techniques to provide sealing. Solder cup, straight and right angle (90°) printed board mount terminations. Three connector variants: 44 (male), 62 and 78 contacts. All other high density connector variants are supplied as Unibody, see description above. Size 22 contacts, professional level performance, IP67.

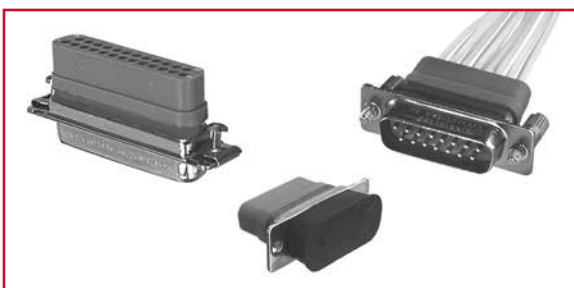

ENVIRO-D, STANDARD DENSITY SEALED, CABLE CONNECTOR, REMOVABLE CRIMP CONTACTS, D-SUBMINIATURE

The EVD series utilizes rear connector grommets to provide a sealed connector for use with removable crimp contacts. Five connector variants, 9 through 50. Size 20 contacts; standard and thermocouple crimp contacts. Immersion per MIL-STD 810. Performance conforms to IP67, and applicable requirements of MIL-DTL-24308 and SAE AS39029.



GENERAL INFORMATION

Ingress Protection Connection Systems 1, 2 and 3	1-5
Unibody and Legacy Design Environmental Sealing Features	6
Connector Sealing Plate	7
Information Relative to Coupling of WD, WDD and EVD Series Connectors.....	8

WD SERIES - IMPROVED UNIBODY DESIGN

Technical Characteristics	9-10
Contact Variants	11
Code 2 Solder Cup	11
Code 3 Straight Printed Board Mount Terminations	11
Code 5 Right Angle (90°) Printed Board Mount Termination	12
Right Angle (90°) and Straight Printed Board Mount Contact Hole Pattern.....	12
Ordering Information.....	13



WDD SERIES - IMPROVED UNIBODY DESIGN

Technical Characteristics	14-15
Contact Variants	16
Code 2 Solder Cup	16
Code 3 Straight Printed Board Mount Terminations	16
Code 4 Right Angle (90°) Printed Board Mount Termination	17
Right Angle (90°) and Straight Printed Board Mount Contact Hole Pattern	17
Ordering Information.....	18



WD SERIES

Technical Characteristics	19-20
Contact Variants	21
Code 2 Solder Cup	21
Code 3 Straight Printed Board Mount Terminations	21
Code 5 Right Angle (90°) Printed Board Mount Termination	22
Right Angle (90°) and Straight Printed Board Mount Contact Hole Pattern	22
Ordering Information.....	23

WDD SERIES

Technical Characteristics	24-25
Contact Variants	26
Code 2 Solder Cup	26
Code 3 Straight Printed Board Mount Terminations	26
Code 4 Right Angle (90°) Printed Board Mount Termination	27
Right Angle (90°) and Straight Printed Board Mount Contact Hole Pattern	27
Ordering Information.....	28



E V D S E R I E S

Technical Characteristics	35-36
Contact Variants	36
Standard Shell Assembly	37
EVD Series Design Environmental Sealing Features	38
Sealing Plug	38
Interfacial Seals and Rear Grommets	38
Contact Reels For Automatic Pneumatic Crimp Tools	40
Ordering Information	41

A C C E S S O R I E S

Cul-de-sac Mounting Accessories	42
Enclosure Wall Mount Sealing Plate	42
Interfacial Seal	42
Composite Hoods	43
Enclosure Wall Cutout	44
Protective Cover	44



U N I Q U E F E A T U R E S

Introduction	45
Other Sealed D-subminiature Connectors Options	45
Machined Aluminum Mounting Plate with Conductive O-ring	46
Outside Wall Enclosure Mount	46
Lightweight Aluminum Hood	46
Other Environmental Connector Offerings	47



A P P L I C A T I O N T O O L S

Introduction	47
Application Tool Cross Reference List	48



A P P E N D I X

Explanation of Ingress Protection (IP) System for Enclosures	49
Description of NEMA Enclosure Types	50
Comparison between NEMA Enclosure Type Numbers and IEC Enclosure Classification Designations	51

EVD SERIES

ACCESSORIES

UNIQUE FEATURES

APPLICATION TOOLS

This page is intentionally left blank



INGRESS PROTECTION CONNECTION SYSTEMS

Electronic equipment is frequently used for outdoor or other applications requiring environmental protection. To answer industry's demand for affordable connection systems compatible with environmental protection to IEC 60529 and NEMA 250-1991 performance requirements for electrical enclosures, Positronic has introduced three dust and water ingress protection connection systems.

SYSTEM 1 is an enclosure mounted connector assembly. The connection system is designed for periodic electrical operation after being exposed to a variety of environmental conditions.

SYSTEM 2 is an enclosure mounted connector assembly, which is coupled to a compatible free cable connector. The connection system is designed for continuous electrical operation while being subjected to varying environmental conditions.

SYSTEM 3 is a cable to cable connection system designed for continuous electrical operation while subjected to varying environmental conditions.

An explanation of the dust and water ingress protection requirements as defined by IEC 60529 Degrees of Protection Provided by Enclosures, and NEMA 250-1991 Enclosures for Electrical Equipment, may be found in the Appendix section of this catalog. (See section beginning on page 49)

It is recommended that readers familiarize themselves with the technical information and ingress protection rating systems contained in the Appendix so that a better understanding of dust and water ingress protection connection systems can be achieved.





CONNECTION SYSTEM 1

FIXED ENCLOSURE MOUNTED CONNECTOR

Provides ingress protection in an unmated condition.

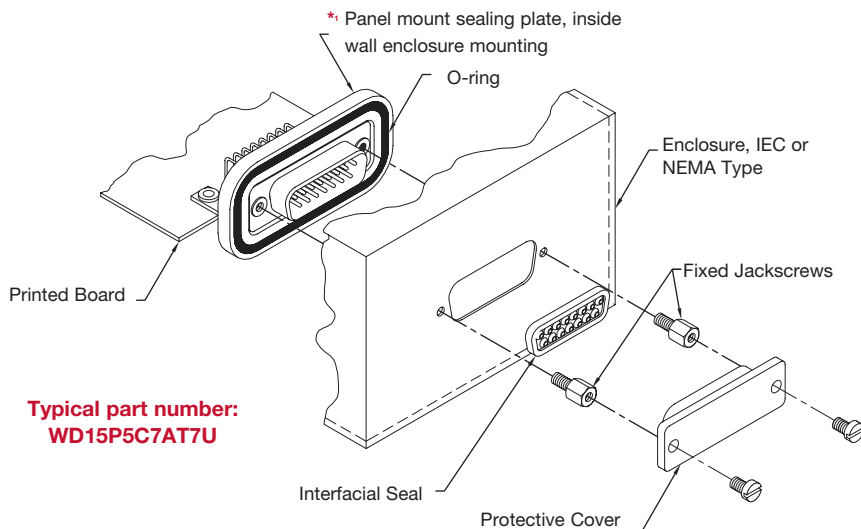

Typical part number:
WD15P5C7AT7U

This type of ingress protection can be achieved by selecting:

WD Series (page 13)

OR

WDD Series (page 18)

Note:

* Outside enclosure wall panel mount sealing plate also available. See Unique Features section, page 46.

SYSTEM 1

System 1 consists of an input/output connector mechanically mounted and sealed to an enclosure. The connector and enclosure together provide a degree of protection from dust and moisture in accordance with IEC or NEMA ingress protection requirements. The enclosure and connector may be exposed to dust, splashing water, rain, or limited water immersion during its use.

“**Corrosion Protection**” option is standard. When “**Corrosion Resistance**” is a requirement, the connector is equipped with stainless steel shells and jackscrews, and contacts plated 0.000030 inch [0.76 μ] gold over nickel.

CONNECTOR/ENCLOSURE ENVIRONMENTAL RATINGS

IEC 60529 Classification
Designations Rated to
IP67 Degree of Protection
(See Appendix for detail)

NEMA Enclosure Types
Approximate Equivalents of
IP67 Degree of Protection
(See Appendix page 49 for details)

IP67, “Corrosion Protected”

Dust tight and limited effects of water immersion, 0.5 meters for 30 minutes. Corrosion protected with zinc plated chromate sealed shells and jackscrews. Contacts plated gold flash over nickel.

NEMA Types 3, 3R, 4 and 6

IP67, “Corrosion Resistance”

Dust tight and limited effects of water immersion 0.5 meters for 30 minutes. Corrosion resistant with stainless steel shells and jackscrews. Contacts plated 0.000030 inch [0.76 μ] gold over nickel.

NEMA Type 4X

For information regarding IEC 60529 and NEMA 250-1991, see Appendix, page 49.

CONNECTION SYSTEM 2

FIXED ENCLOSURE MOUNTED CONNECTOR MATED TO FREE CABLE CONNECTOR

Provides ingress protection of connector system for continuous electrical operation.

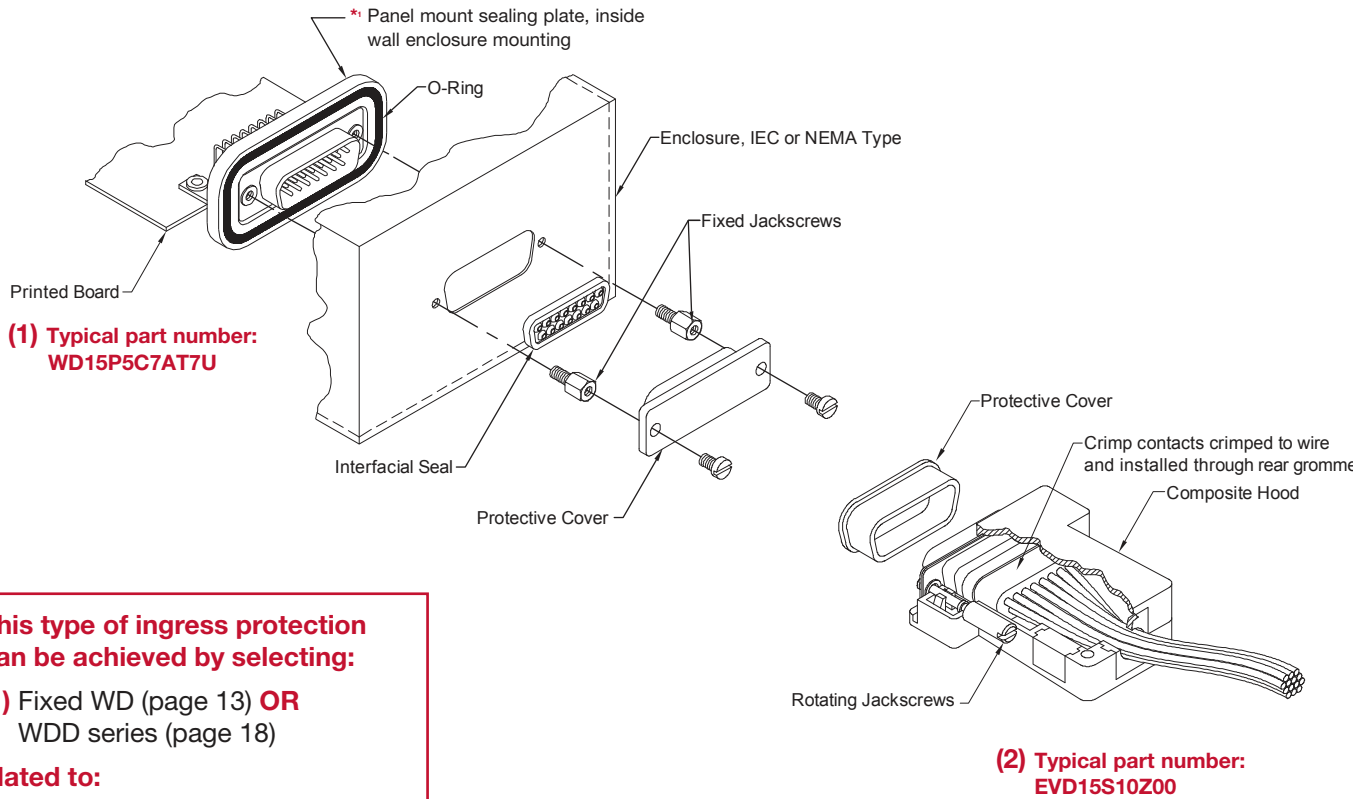

This type of ingress protection can be achieved by selecting:

(1) Fixed WD (page 13) OR WDD series (page 18)

Mated to:

(2) Free cable EVD series (page 41)

Note:

*1. Outside enclosure wall panel mount sealing plate also available. See Unique Features section, page 46.

SYSTEM 2

System 2 consists of a fixed input/output connector and a compatible free cable connector. The system is normally in operation and may be exposed to dust, splashing water, rain, limited water immersion or hose directed water.

The fixed connector is selected from the connectors offered in System 1. The mating (free or cable) connector must be electrically, mechanically, and chemically compatible with

the fixed connector. This requirement enables System 2 to provide the desired **“Corrosion Resistance”** or **“Corrosion Protection”** and maintain the degree of ingress protection IP67 as specified in IEC 60529.

The male connector of System 2 is always equipped with an interfacial seal.

This page is intentionally left blank



CONNECTION SYSTEM 3

FREE CABLE-TO-CABLE CONNECTORS WITH CRIMP REMOVABLE CONTACTS

Provides ingress protection of connector system for continuous electrical operation.

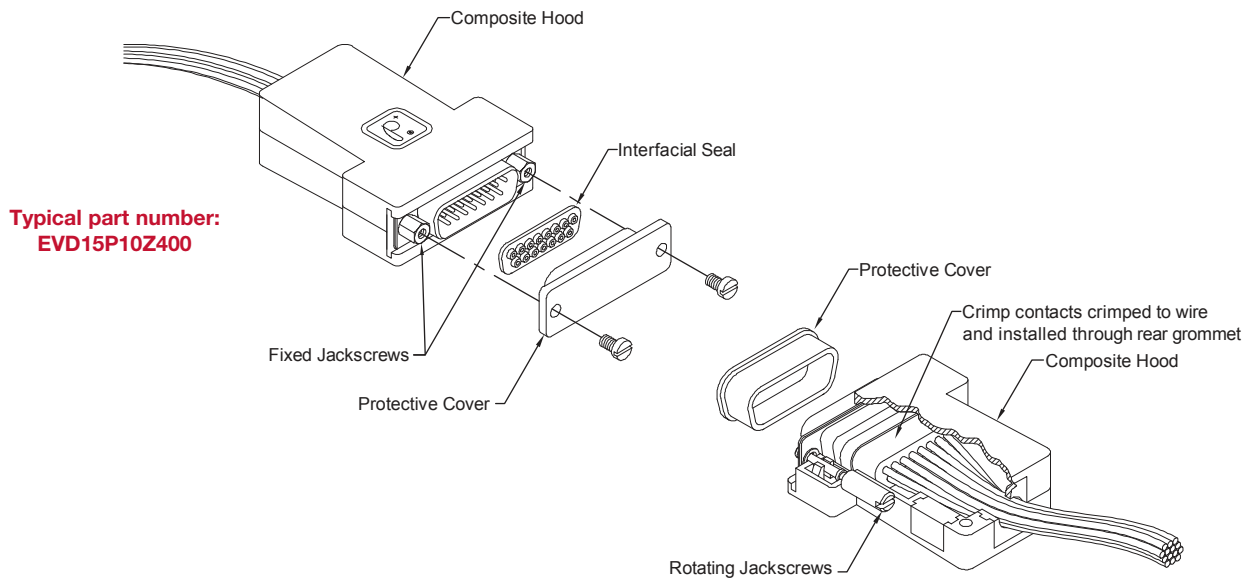

This type of ingress protection can be achieved by selecting:

Free cable EVD series (page 41)

SYSTEM 3

System 3 is a cable-to-cable interconnection system consisting of two free cable connectors. The system is normally in operation and may be exposed to dust, splashing water, rain, limited water immersion or hose directed water.

The connectors must be electrically, mechanically, and chemically compatible with each other. This requirement

enables System 3 to provide the desired level of **“Corrosion Resistance”** or **“Corrosion Protection”** and maintain the degree of ingress protection IP67 as specified in IEC 60529.

The male connector of System 3 is always equipped with an interfacial seal.

For information regarding IEC 60529 and NEMA 250-1991, see Appendix, page 49.



WD SERIES UNIBODY DESIGN
ENVIRONMENTAL SEALING FEATURES

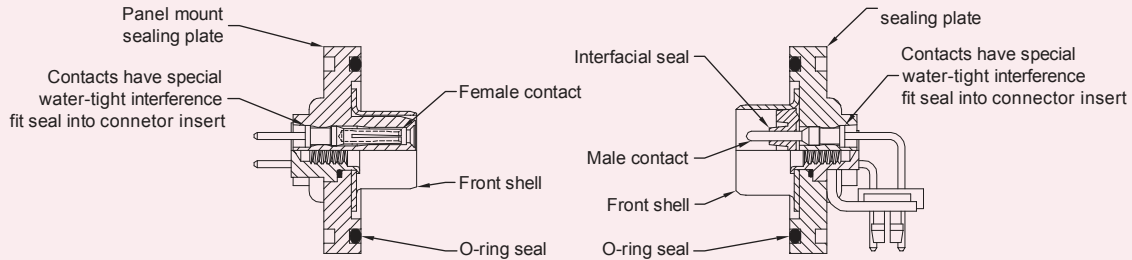

- FEATURES:**
- Popular, economical option for applications requiring **sealed** connectors.
 - One piece **Unibody** connector insert eliminates need for secondary sealing processes.
 - Improved temperature range, increased performance, and lower cost.

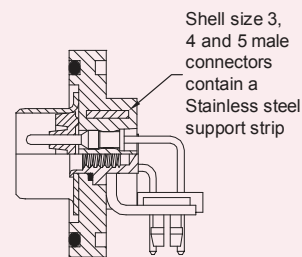

WD SERIES LEGACY DESIGN
ENVIRONMENTAL SEALING FEATURES

ENCLOSURE MOUNTED CONNECTORS
SYSTEMS 1 AND 2

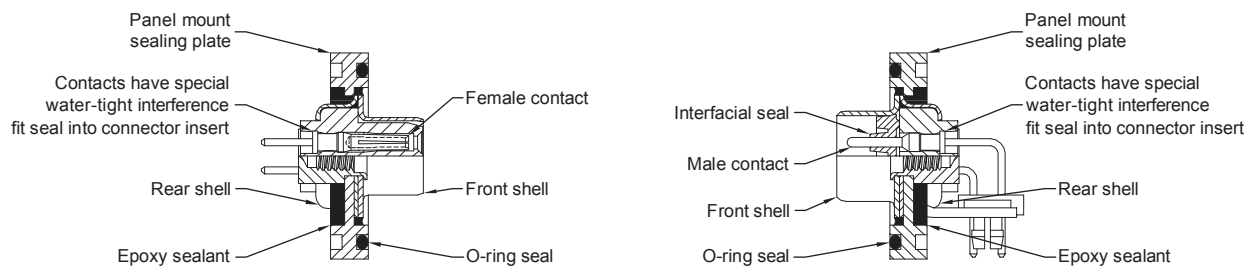

Information regarding the **SEALING DESIGN FEATURES** of the EVD series on page 38.



CONNECTOR SEALING PLATE

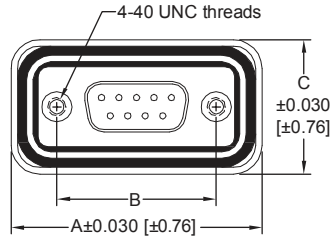

SHELL SIZE	CONNECTOR VARIANT		A	B	C
	WD SERIES STANDARD DENSITY	WDD SERIES HIGH DENSITY			
1	9	15	1.550 [39.37]	0.984 [24.99]	0.830 [21.08]
2	15	26	1.878 [47.70]	1.312 [33.32]	0.830 [21.08]
3	25	44	2.418 [61.42]	1.852 [47.04]	0.830 [21.08]
4	37	62	3.066 [77.88]	2.500 [63.50]	0.830 [21.08]
5	50	78	2.972 [75.49]	2.406 [61.11]	0.941 [23.90]
6	--	104	Contact Technical Sales For Availability		

Connectors Designed To Customer Specifications

Positronic's WD / WDD / EVD connectors can be modified to customers specifications.

Examples: select loading of contacts for cost savings or to gain creepage and clearance distances;
longer printed circuit board terminations; customer specified hardware.

Contact Technical Sales with your particular requirements.



Positronic
connectpositronic.com

GENERAL INFORMATION

Environmental
D-Sub

INFORMATION RELATIVE TO COUPLING OF WD, WDD AND EVD SERIES CONNECTORS RECOMMENDED COUPLING DIMENSION TO ENSURE WATER AND DUST INGRESS PROTECTION

SHELL SIZE	SERIES		G	
	WD, EVD	WDD	MIN.	MAX.
1	9	15	0.230 [5.84]	0.260 [6.60]
2	15	26	0.230 [5.84]	0.260 [6.60]
3	25	44	0.221 [5.61]	0.251 [6.38]
4	37	62	0.221 [5.61]	0.251 [6.38]
5	50	78	0.221 [5.61]	0.251 [6.38]

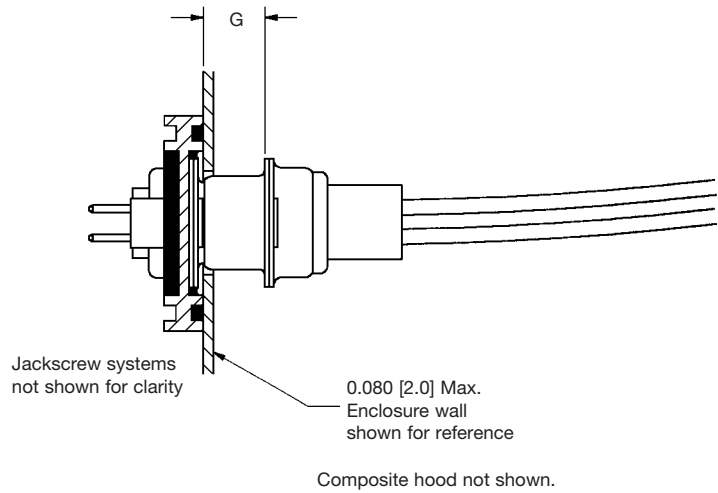

WD25P5C7AT7S

WDD15F220Z40



-  Popular, economical option for applications requiring **sealed** connectors.
-  One piece **Unibody** connector insert eliminates need for secondary sealing processes.
See page 6 for details.
-  Improved temperature range, increased performance, and lower cost.
-  **Fixed**, size 20 contacts
-  Terminations include solder cup, straight and right angle (90°) printed board mount.
-  Five connector variants with 9, 15, 25, 37, and 50.
-  Corrosion protected and corrosion resistant options.
-  A wide variety of options and accessories.



Connectors Conforms to:

- IP 67 per IEC 60529
- IEC 60807-2, Performance Level 2
- UL File # E49351
- CSA File # LR 54219

Telecommunication:

- UL File # E140980

TECHNICAL CHARACTERISTICS

ENVIRONMENTAL CHARACTERISTICS:

WIN-D series connectors mounted on IEC 60529 or NEMA 250-1991 enclosures.

WIN-D Connector Panel mount sealing plates, when mounted on the walls of enclosures, maintain the dust and water ingress protection rating of IEC 60529 or NEMA 250 enclosure on which they are mounted. WIN-D connector enclosure assemblies provide dust and water ingress protection to IP67. Refer to Appendix A for details of IP 67 ratings and NEMA enclosure types 6 and 4X, as well as other IEC and NEMA enclosures having less stringent environmental requirements.

ENVIRONMENTAL TEST SPECIFICATIONS:

Applicable IEC Moisture Tests:

IP65 IEC 60529 Test 14.2.5: Spray nozzle 6.3 mm diameter, delivery rate 12.5 liters per minute, 1 minute duration of connector exposure to spray. When conducting this test on Portable Enclosure Connectors, the protective cover must be securely fastened over the face of the connector. **Requirements:** No water to have penetrated enclosure through connector.

IP67 IEC 60529, Test 14.2.7: Temporary immersion, 1.0 meter for
continued on next page. . . .



Positronic
connectpositronic.com



WD UNIBODY SERIES

IMPROVED UNIBODY DESIGN
PROFESSIONAL QUALITY
STANDARD DENSITY FIXED CONTACTS

Environmental
D-Sub

TECHNICAL CHARACTERISTICS, *continued*

continued from previous page. . . .

30 minutes. **Requirements:** No water to have penetrated enclosure through connector.

Applicable IEC Connector Tests After Moisture Conditioning Has Been Performed:

IEC 60512-2, Test 3a: Insulation Resistance
IEC 60512-2, Test 4a: Voltage proof
Requirements: Portable enclosure. 1 G ohm minimum insulation resistance after connector face and contacts are dried. Voltage proof 1,000 V rms.

- It is recommended that connectors be tested in the specific application.
- Service life of connectors cannot be predicted for all applications.

MATERIALS AND FINISHES:

Connector Insert: Nylon resin, UL 94V-0 black color.
Contacts: Precision machined copper alloy.
Contact Plating:
Corrosion Protection: Gold flash over nickel plate.
Corrosion Resistant: Gold plate 0.000030 inch [0.76 μ] over nickel plate.

Shells, Jackscrew Systems and

Cul-de-sac Mounting Accessories:
Corrosion Protection: Steel, zinc plated with chromate seal.
Corrosion Resistant: Stainless steel passivated.
Push-on Fasteners: Phosphor bronze with tin plate.
Angle Brackets: Brass, zinc plate with chromate seal.
Interfacial Seal: Thermoplastic Elastomer (TPE), Santoprene™ or equivalent.

Panel Mount Sealing

Plate Assembly: Glass filled thermoplastic with elastomer O-ring. Shell size 3, 4, and 5 male connectors contain stainless steel support strip.

Protective Cover Over Connector Shell: Conductive polyethylene or conductive polyester.

MECHANICAL CHARACTERISTICS:

Size 20 Fixed Contacts: Male contact - 0.040 inch [1.02 mm] mating diameter. Female contact - rugged open entry design.

Contact Retention in Insulator: 6 lbs. [27N]

Contact Terminations: Solder cup contacts - 0.042 inch [1.06 mm] minimum hole diameter for 20 AWG [0.5 mm²] wire maximum.

Straight printed board mount - 0.028 inch [0.71 mm] termination diameter.

Right angle (90°) printed board mount - 0.028 inch [0.71 mm] termination diameter for all printed board contact footprints.

Coding (keying): Trapezoidally shaped shells.

Enclosure Mounting

Accessories: Cul-de-sac blind hole fasteners, angle brackets and push-on fasteners.

Inside Wall

Enclosure Mount: Minimum thickness 0.040 inch [1.02 mm]. Maximum thickness 0.080 inch [2.03 mm].

Locking Systems: Jackscrews.

Mechanical Operations: 500 operations minimum per IEC 60512-5.

Required Sealing

Plate Mounting Torque: 1.75 in-lb. [0.20 Nm] minimum.
2.25 in-lb. [0.25 Nm] maximum.

ELECTRICAL CHARACTERISTICS:

Contact Current Rating: 7.5 amperes nominal,

Initial Contact Resistance: 0.008 ohms maximum.

Insulator Resistance: 5 G ohms.

Clearance and Creepage

Distance Minimum: 0.039 inch [1.0mm].

Proof Voltage: 1000 V r.m.s.

Working Voltage: 300 V r.m.s.

CLIMATIC CHARACTERISTICS:

Temperature Range: -40°C to +125°C

Visit our web site for the latest catalog updates and supplements at
www.connectpositronic.com/connector-details/d-subminiature/environmentally-sealed/catalog

Do you need 2-D drawings or 3-D models?

Once you have made a connector selection, contact Technical Sales if you would like a 2-D drawing or 3-D model. If we do not have your specific part number on file, we can create one for you. Or, please visit www.connectpositronic.com and use the search function.

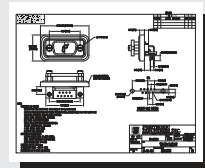



CONTACT VARIANTS *

FACE VIEW OF MALE OR REAR VIEW OF FEMALE

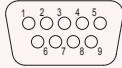

WD 9

Available with male and female contacts

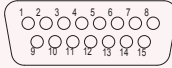

WD 15

Available with male and female contacts

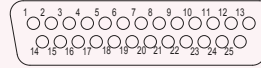

WD 25

Currently available with female contacts.
For male contact variants, see page 21.

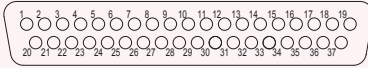

WD 37

Available with male and female contacts

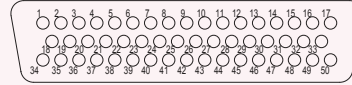

WD 50

Currently available with female contacts.
For male contact variants, see page 21.

* If a variant is not listed above, consult Technical Sales, as Positronic is ready to support requirements for other D-subminiature variants and is tooling additional variants. For information on existing design variants, see page 21.
For sealing plate dimensions see page 7.

SOLDER CUP TERMINATION

WITH ENCLOSURE WALL MOUNT SEALING PLATE

CODE 2

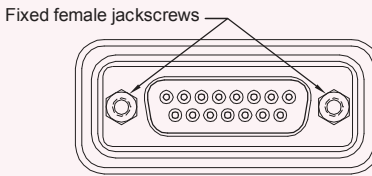
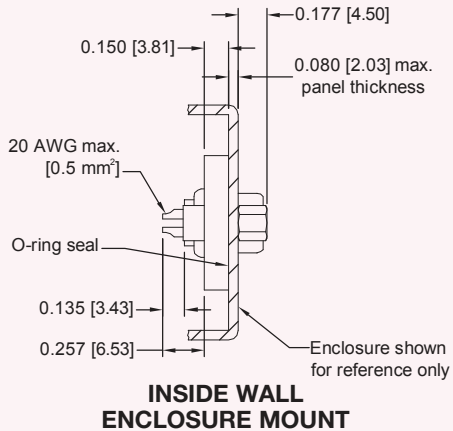

Typical part number:
WD15F2C5AT7U

OUTSIDE WALL ENCLOSURE MOUNT
Not available in Unibody design.
See Unique Feature section, page 46.

STRAIGHT SOLDER PRINTED BOARD MOUNT TERMINATION

WITH ENCLOSURE WALL MOUNT SEALING PLATE

CODE 3, 0.150 [3.81] CONTACT EXTENSION

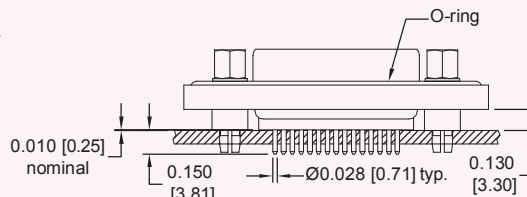
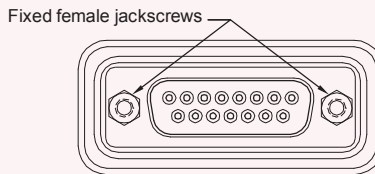
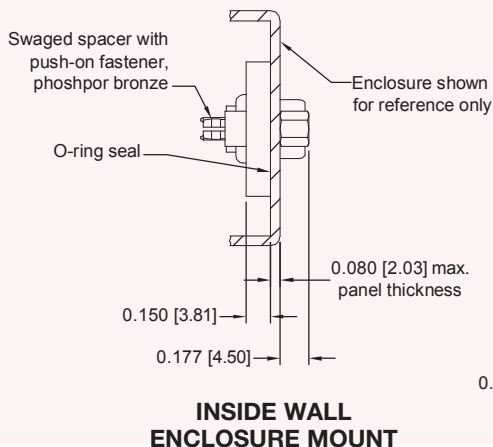

OUTSIDE WALL ENCLOSURE MOUNT
Not available in Unibody design.
See Unique Feature section, page 46.

Typical part number:
WD15F3C8AT7U



Positronic
connectpositronic.com



WD UNIBODY SERIES

IMPROVED UNIBODY DESIGN
PROFESSIONAL QUALITY
STANDARD DENSITY FIXED CONTACTS

Environmental
D-Sub

RIGHT ANGLE (90°) PRINTED BOARD MOUNT TERMINATION

WITH ENCLOSURE MOUNT SEALING PLATE
CODE 5, 0.188 [4.78] CONTACT EXTENSION

INSIDE WALL ENCLOSURE MOUNT

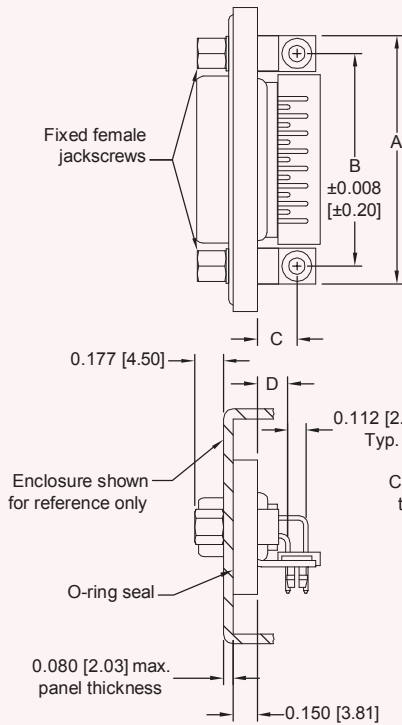

Typical Part Number:
WD15P5C7AT7U

WD**5***U 0.188 [4.78] CONTACT EXTENSION				
PART NUMBER	A	B	C	D
WD9*5***U	1.204 [30.58]	0.984 [24.99]	0.244 [6.20]	0.188 [4.78]
WD15*5***U	1.532 [38.91]	1.312 [33.32]	0.244 [6.20]	0.188 [4.78]
WD25F5***U	2.072 [52.63]	1.852 [47.04]	0.244 [6.20]	0.188 [4.78]
WD37*5***U	2.720 [69.09]	2.500 [63.50]	0.244 [6.20]	0.188 [4.78]
WD50F5***U	2.626 [66.70]	2.406 [61.11]	0.300 [7.62]	0.188 [4.78]

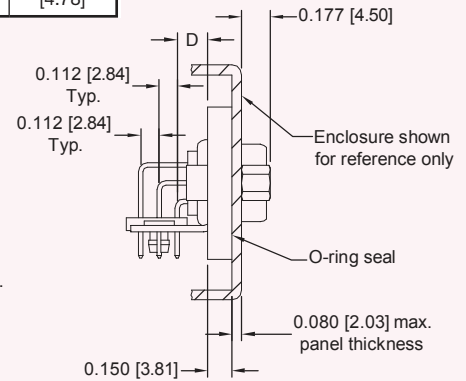
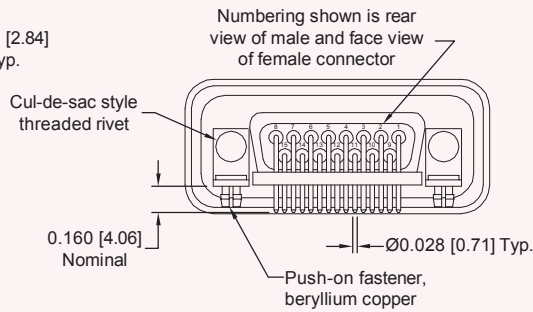

Typical Part Number:
WD50F5C7AT7U

RIGHT ANGLE (90°) AND STRAIGHT PRINTED BOARD CONTACT HOLE PATTERN

MOUNT CONNECTOR WITH MATING FACE POSITIONED TO FOLLOW DIRECTION OF ARROWS.

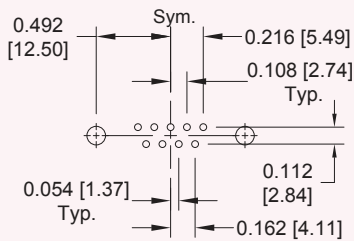

WD 9

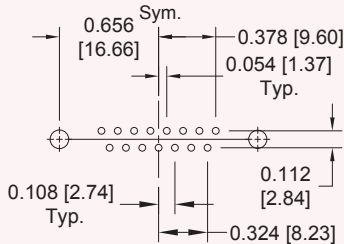

WD 15

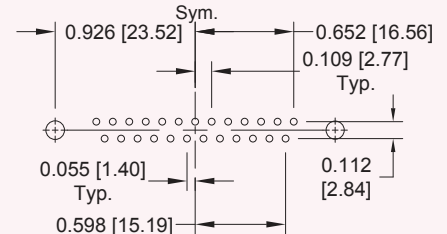

WD 25

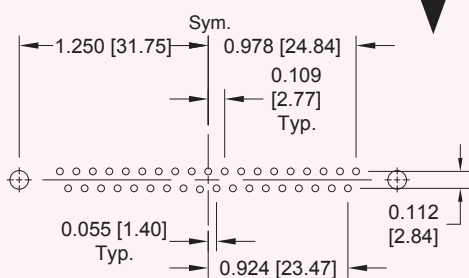

WD 37

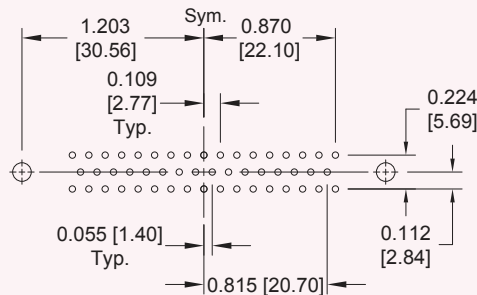

WD 50

SUGGESTED PRINTED BOARD HOLE SIZES:

Suggest 0.123 ±0.003 [3.12] Ø holes for mounting connector with push-on fasteners.

Suggest 0.045 [1.14] Ø hole for contact termination positions.



ORDERING INFORMATION - CODE NUMBERING SYSTEM

Specify Complete Connector By Selecting An Option From Step 1 Through 8

† **Unibody is the preferred design.** If a variant is not listed in Step 2, consult Technical Sales, as Positronic is ready to support requirements for other D-subminiature variants and is tooling additional variants. For information on existing design variants, see page 21.

STEP	1	2	3	4	5	6	7	8	9	10
EXAMPLE	WD	9	F	2	C5	A	T7	SU	/AA	
STEP 1 - BASIC SERIES WD - WD Unibody series										STEP 10 - SPECIAL OPTIONS CONTACT TECHNICAL SALES FOR SPECIAL OPTIONS
† STEP 2 - CONNECTOR VARIANTS 9 - Male and Female 15 - Male and Female † 25 - Female only 37 - Male and Female † 50 - Female only										STEP 9 - ENVIRONMENTAL COMPLIANCE OPTIONS /AA - Compliant per EU Directive 2002/95/EC (RoHS) NOTE: If compliance to environmental legislation is not required, this step will not be used. Example: WD9F2C5AT7SU
STEP 3 - CONNECTOR GENDER P - Male with interfacial seal F - Female										STEP 8 - SHELLS AND ACCESSORY OPTIONS U - Corrosion Protected Unibody Design Steel shells and jackscrews zinc plated with chromate seal. Contacts gold flash over nickel plate. SU- Corrosion Resistant Unibody Design Stainless steel shells and jackscrews Contacts 0.000030 inch [0.76µ] gold plated over nickel.
STEP 4 - CONTACT TERMINATION TYPE 2 - Solder cup 3 - Solder, straight printed board mount with 0.150 [3.81] tail length. 5 - Solder, right angle (90°) printed board mount, contact extension 0.188 [4.78].										*1 STEP 7 - FEMALE FIXED JACKSCREWS T7 - Always used when ordering C5, C7 and C8 (Step 5).
*1 STEP 5 - CUL-DE-SAC STYLE MOUNTING ACCESSORIES C5 - Inside wall mounting for Code 2 and 3 (step 4) only. C7 - Inside wall mounting for Code 5 (step 4), right angle (90°) printed board mount only. Consists of an assembly of angle bracket, alignment bar and push-on fastener. C8 - Inside wall mounting for Code 3 (step 4) only. Includes push-on fastener. NOTE: For C9 outside wall mounting option, refer to Unique Features section, page 46.										*1 STEP 6 - ENCLOSURE WALL MOUNT SEALING PLATE A - Inside wall enclosure mounted connector.

NOTE:

*1 For additional information listed in Steps 5, 6, and 7, see the Accessories section, page 42.

Do you need 2-D drawings or 3-D models?

See page 10 for more information



Positronic
connectpositronic.com



WDD UNIBODY SERIES

IMPROVED UNIBODY DESIGN
PROFESSIONAL QUALITY
HIGH DENSITY FIXED CONTACTS

Environmental
D-Sub



Popular, economical, high density option for applications requiring **sealed** connectors.



One piece **Unibody** connector insert eliminates need for secondary sealing processes.

See page 6 for details.



Improved temperature range, increased performance, and lower cost.



Fixed, size 22 contacts



Terminations include solder cup, straight and right angle (90°) printed board mount.



Three connector variants include 15, 26 and 44, with more being tooled.

See WDD section (page 26) for all other high density sizes.



Corrosion protected and corrosion resistant options.



A wide variety of options and accessories.



WDD UNIBODY

TECHNICAL CHARACTERISTICS

ENVIRONMENTAL CHARACTERISTICS:

WIN-DD series connectors mounted on IEC 60529 or NEMA 250-1991 enclosures.

WIN-DD connector panel mount sealing plates, when mounted on the walls of enclosures, maintain the dust and water ingress protection rating of IEC 60529 or NEMA 250 enclosure on which they are mounted. WIN-DD connector enclosure assemblies provide dust and water ingress protection to IP67. Refer to Appendix A for detail of IP 67 ratings and NEMA enclosure types 6 and 4X, as well as other enclosures having less stringent environmental requirements.

ENVIRONMENTAL TEST SPECIFICATIONS:

Applicable IEC Moisture Tests:

IP65 IEC 60529 Test 14.2.5: Spray nozzle 6.3 mm diameter, delivery rate 12.5 liters per minute, 1 minute duration of connector exposure to spray. When conducting this test on Portable Enclosure Connectors, the protective cover must be securely fastened over the face of the connector. **Requirements:** No water to have penetrated enclosure through connector.

continued on next page. . . .



TECHNICAL CHARACTERISTICS, *continued*

continued from previous page. . . .

IP67 IEC 60529 Test 14.2.7: Temporary immersion, 1.0 meter for 30 minutes. **Requirements:** No water to have penetrated enclosure through connector.

Applicable IEC Connector Tests After Moisture Conditioning Has Been Performed:

IEC 60512-2, Test 3a: Insulation Resistance
IEC 60512-2, Test 4a: Voltage proof
Requirements: Portable enclosure. 1 G ohm minimum insulation resistance after connector face and contacts are dried. Voltage proof 1,000 V rms.

- It is recommended that connectors be tested in the specific application.
- Service life of connectors cannot be predicted for all applications.

MATERIALS AND FINISHES:

Connector Insert: Nylon resin, UL 94V-0 black color.
Contacts: Precision machined copper alloy
Contact Plating:
Corrosion Protection: Gold flash over nickel plate.
Corrosion Resistant: Gold plate 0.000030 inch [0.76 μ] over nickel plate.

Shell, Jackscrew Systems and

Cul-de-sac Mounting Accessories:
Corrosion Protection: Steel, zinc plated with chromate seal.
Corrosion Resistant: Stainless steel passivated.

Push-on Fasteners: Phosphor bronze with tin plate.
Angle Brackets: Brass, zinc plate with chromate seal.
Interfacial Seal: Thermoplastic Elastomer (TPE), Santoprene™ or equivalent.

Panel Mount Sealing Plate Assembly: Glass filled thermoplastic with elastomer O-ring.

Protective Cover Over Connector Shell: Conductive polyethylene or conductive polyester.

MECHANICAL CHARACTERISTICS:

Size 22 Fixed Contacts: Male contact - 0.030 inch [0.75 mm] mating diameter. Female contact - rugged open entry design.

Contact Retention in Connector insert: 6 lbs. [27N]
Contact Terminations: Solder cup contacts - 0.035 inch [0.89 mm] minimum hole diameter for 22 AWG [0.3 mm²] wire maximum. Straight printed board mount - 0.020 inch [0.51 mm] termination diameter. Right angle (90°) printed board mount contact terminations 0.030 inch [0.76 mm] termination diameter. Trapezoidally shaped shells.

Coding (keying):
Enclosure Mounting Accessories: Cul-de-sac blind hole fasteners, angle brackets and push-on fasteners.

Inside Wall Enclosure Mount: Minimum thickness 0.040 inch [1.02 mm]. Maximum thickness 0.080 inch [2.03 mm].

Locking Systems: Jackscrews.
Mechanical Operations: 500 operations minimum per IEC 60512-5.
Required Sealing: 1.75 in-lb. [0.20 Nm] minimum.

Plate Mounting Torque: 2.25 in-lb. [0.25 Nm] maximum.

ELECTRICAL CHARACTERISTICS:

Contact Current Rating: 5 amperes nominal
Initial Contact Resistance: 0.010 ohms maximum.
Insulator Resistance: 5 G ohms.
Clearance and Creepage Distance Minimum: 0.039 inch [1.0mm].
Proof Voltage: 1000 V r.m.s.
Working Voltage: 300 V r.m.s.

CLIMATIC CHARACTERISTICS:

Temperature Range: -40°C to +125°C

WDD UNIBODY

Visit our web site for the latest catalog updates and supplements at www.connectpositronic.com/connector-details/d-subminiature/environmentally-sealed/catalog

Do you need 2-D drawings or 3-D models?

Once you have made a connector selection, contact Technical Sales if you would like a 2-D drawing or 3-D model. If we do not have your specific part number on file, we can create one for you. Or, please visit www.connectpositronic.com and use the search function.

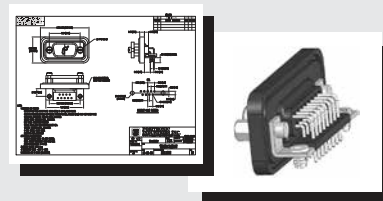



Positronic
connectpositronic.com



WDD UNIBODY SERIES

IMPROVED UNIBODY DESIGN
PROFESSIONAL QUALITY
HIGH DENSITY FIXED CONTACTS

Environmental
D-Sub

CONTACT VARIANTS *

FACE VIEW OF MALE OR REAR VIEW OF FEMALE

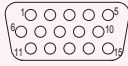

WDD 15

Available with male and female contacts

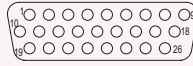

WDD 26

Available with male and female contacts

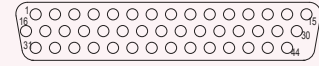

WDD 44

Currently available with female contacts.
For male contact variants, see page 26.

* If a variant is not listed above, consult Technical Sales, as Positronic is ready to support requirements for other D-subminiature variants and is tooling additional variants. For information on existing design variants, see page 26.
For sealing plate dimensions see page 7.

SOLDER CUP TERMINATION

WITH ENCLOSURE WALL MOUNT SEALING PLATE
CODE 2

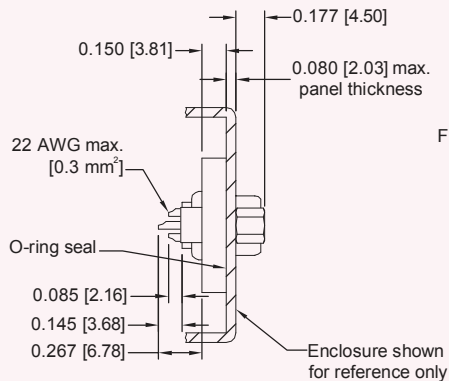

INSIDE WALL ENCLOSURE MOUNT

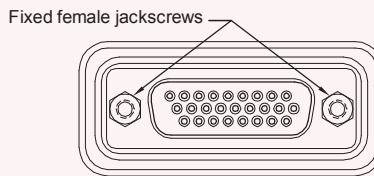

Typical part number:
WDD26P2C5AT7U

OUTSIDE WALL ENCLOSURE MOUNT
Not available in Unibody design.
See Unique Feature section, page 46.

STRAIGHT SOLDER PRINTED BOARD MOUNT TERMINATION

WITH ENCLOSURE WALL MOUNT SEALING PLATE
CODE 3, 0.150 [3.81] CONTACT EXTENSION

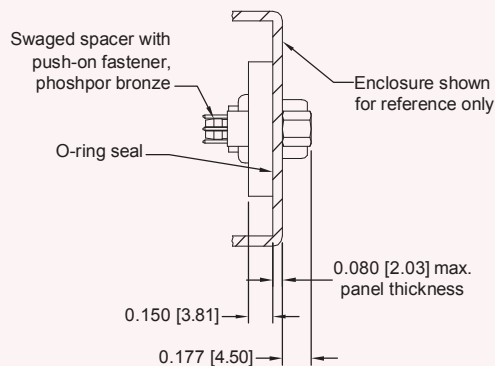

INSIDE WALL ENCLOSURE MOUNT

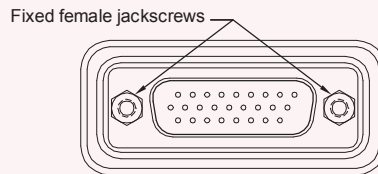

Typical part number:
WDD26P3C8AT7U

OUTSIDE WALL ENCLOSURE MOUNT
Not available in Unibody design.
See Unique Feature section, page 46.

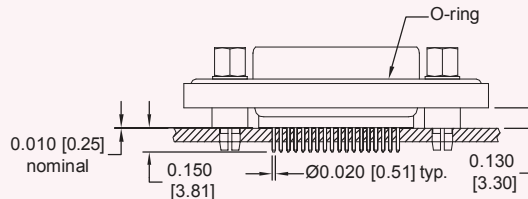

WDD UNIBODY



RIGHT ANGLE (90°) PRINTED BOARD MOUNT TERMINATION

WITH ENCLOSURE MOUNT SEALING PLATE
CODE 4, 0.219 [5.56] CONTACT EXTENSION

INSIDE WALL ENCLOSURE MOUNT

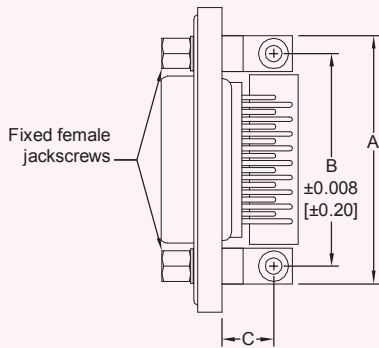

WDD26*4**** 0.219 [5.56] CONTACT EXTENSION				
PART NUMBER	A	B	C	D
WDD15*4****	1.204 [30.58]	0.984 [24.99]	0.319 [8.10]	0.219 [5.56]
WDD26*4****	1.532 [38.91]	1.312 [33.32]	0.319 [8.10]	0.219 [5.56]
WDD44F4****	2.072 [52.63]	1.852 [47.04]	0.319 [8.10]	0.219 [5.56]

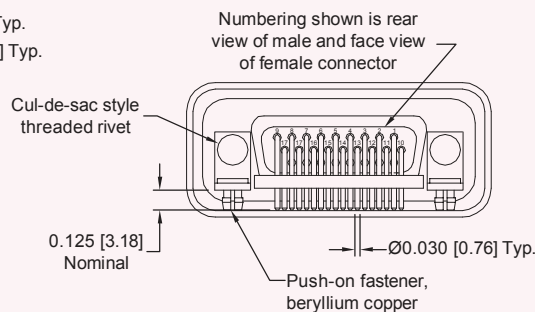
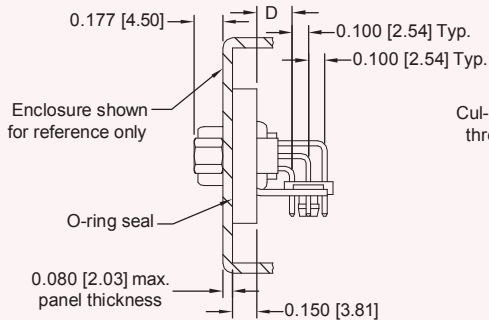

Typical part number:
WDD26P4C7AT7U

RIGHT ANGLE (90°) AND STRAIGHT PRINTED BOARD CONTACT HOLE PATTERN

MOUNT CONNECTOR WITH MATING FACE POSITIONED TO FOLLOW DIRECTION OF ARROWS.

WDD15 MALE

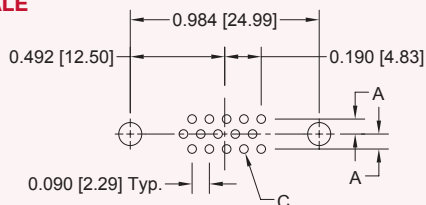

WDD15 FEMALE

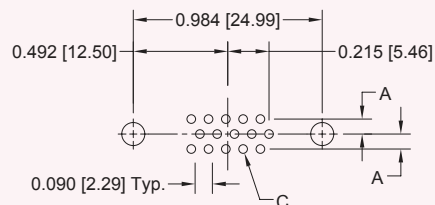

WDD26 MALE

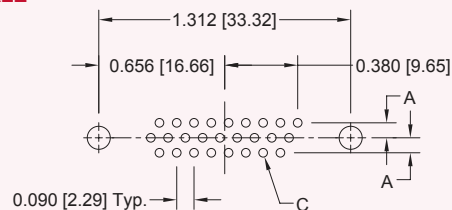

WDD26 FEMALE

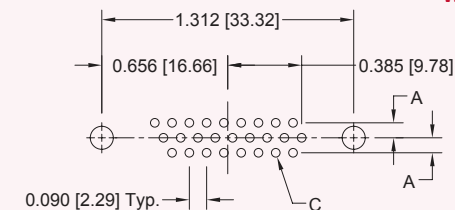

CODE NUMBER	A	C
3	0.078 [1.98]	0.035 [0.89]
4	0.100 [2.54]	0.045 [1.14]

WDD44 FEMALE

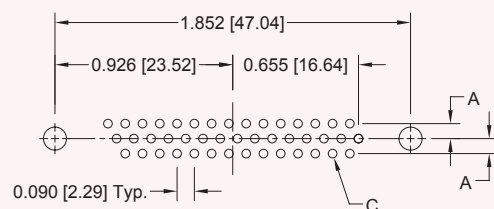

SUGGESTED PRINTED BOARD HOLE SIZES:

Suggest 0.123 ±0.003 [3.12] Ø holes for mounting connector with push-on fasteners

DIMENSIONS ARE IN INCHES [MILLIMETERS].
ALL DIMENSIONS ARE SUBJECT TO CHANGE.



Positronic
connectpositronic.com



WDD UNIBODY SERIES

IMPROVED UNIBODY DESIGN
PROFESSIONAL QUALITY
HIGH DENSITY FIXED CONTACTS

Environmental
D-Sub

ORDERING INFORMATION - CODE NUMBERING SYSTEM

Specify Complete Connector By Selecting An Option From Step 1 Through 8

† Unibody is the preferred design. If a variant is not listed in Step 2, consult Technical Sales, as Positronic is ready to support requirements for other D-subminiature variants and is tooling additional variants. For information on existing design variants, see page 26.

STEP	1	2	3	4	5	6	7	8	9	10
EXAMPLE	WDD	26	F	2	C5	A	T7	SU	/AA	

STEP 1 - BASIC SERIES

WDD - WDD Unibody series

† STEP 2 - CONNECTOR VARIANTS

- 15 - Male and Female
- 26 - Male and Female
- † 44 - Female only

STEP 3 - CONNECTOR GENDER

- P - Male with interfacial seal
- F - Female

STEP 4 - CONTACT TERMINATION TYPE

- 2 - Solder cup.
- 3 - Solder, straight printed board mount with 0.150 [3.81] tail length.
- 4 - Solder, right angle (90°) printed board mount, contact extension 0.219 [5.56].

*1 STEP 5 - CUL-DE-SAC STYLE MOUNTING ACCESSORIES

- C5 - Inside wall mounting for Code 2 and 3 (step 4) only.
- C7 - Inside wall mounting for Code 4 (step 4), right angle (90°) printed board mount only. Consists of an assembly of angle bracket, alignment bar and push-on fastener.
- C8 - Inside wall mounting for Code 3 (step 4) only. Includes push-on fastener.

NOTE: For C9 outside wall mounting option, refer to Unique Features section, page 46.

NOTE:

- *1 For additional information listed in Steps 5, 6, and 7, see the Accessories section, page 42.

STEP 10 - SPECIAL OPTIONS

CONTACT TECHNICAL SALES FOR SPECIAL OPTIONS

STEP 9 - ENVIRONMENTAL COMPLIANCE OPTIONS

/AA - Compliant per EU Directive 2002/95/EC (RoHS)

NOTE: If compliance to environmental legislation is not required, this step will not be used. Example: WDD26F2C5AT7SU



STEP 8 - SHELLS AND ACCESSORY OPTIONS

- U - **Corrosion Protected Unibody Design**
Steel shells and jackscrews zinc plated with chromate seal. Contacts gold flash over nickel plate.
- SU - **Corrosion Resistant Unibody Design**
Stainless steel shells and jackscrews
Contacts 0.000030 inch [0.76 μ] gold plated over nickel.

*1 STEP 7 - FEMALE FIXED JACKSCREWS

- T7 - Always used when ordering C5, C7 and C8 (step 5).

*1 STEP 6 - ENCLOSURE WALL MOUNT SEALING PLATE

- A - Inside wall enclosure mounted connector.

Do you need 2-D drawings or 3-D models?
See page 10 for more information



- ✓ Popular, economical option for applications requiring **sealed** connectors.
- ✓ Precision sealing process ensures environmental performance. *See page 6 for details.*
- ✓ **Fixed**, size 20 contacts
- ✓ Terminations include solder cup, straight and right angle (90°) printed board mount.
- ✓ Five connector variants with 9, 15, 25, 37, and 50 contacts. *See WD Unibody section (page 11) for variants supplied in Unibody design.*
- ✓ Corrosion protected and corrosion resistant options.
- ✓ A wide variety of options and accessories.

Connectors Conforms to:

- IP 67 per IEC 60529
- IEC 60807-2, performance level 2
- UL File # E49351
- CSA File # LR 54219

Telecommunication:

- UL File # E140980

TECHNICAL CHARACTERISTICS

ENVIRONMENTAL CHARACTERISTICS:

WIN-D series connectors mounted on IEC 60529 or NEMA 250-1991 enclosures for electrical equipment.

WIN-D connector panel mount sealing plates, when mounted on the walls of enclosures, maintain the dust and water ingress protection rating of IEC 60529 or NEMA 250 enclosure on which they are mounted. WIN-D connector enclosure assemblies provide dust and water ingress protection to IP67 which allows temporary immersion in water to a depth of 0.5 meters for 30 minutes without ingress of water or dust to the enclosure. Refer to Appendix A for details of IP67 ratings and NEMA enclosure types 6 and 4X, as well as other IEC and NEMA enclosures having less stringent environmental requirements.

WIN-D series cable connector with cable support WIN-D cable connectors meet all the requirement of IEC 60807-2 Performance Level 2, plus the ingress protection requirement of IP67 thereby maintaining the electrical integrity and the ingress protection level of the connection system.

ENVIRONMENTAL TEST SPECIFICATIONS

Applicable IEC Moisture Tests

IP65 IEC 60529 Test 14.2.5 Spray nozzle 6.3 mm diameter, delivery rate 12.5 liters per minute, 1 minute duration of connector exposure to spray. When conducting this test on System 1 – Portable Enclosure Connectors, the protective cover must be securely fastened over the face of the connector. **Requirements:** No water to have penetrated enclosure through connector.

IP67 IEC 60529 Test 14.2.7 Temporary immersion, 0.5 meters for 30 minutes. **Requirements:** No water to have penetrated enclosure through connector.

continued on next page. . . .



Positronic
connectpositronic.com

WD SERIES

PROFESSIONAL QUALITY STANDARD DENSITY FIXED CONTACTS

Environmental
D-Sub

TECHNICAL CHARACTERISTICS

... continued from previous page.

Applicable IEC Connector Tests After Moisture Exposure Tests Have Been Performed

IEC 60512-2, Test 3a: Insulation Resistance
IEC 60512-2, Test 4a: Voltage proof
Requirements:

- System 1 –** Portable enclosure. 1 G ohm minimum insulation resistance after connector face and contacts are dried. Voltage proof 1,000 V rms.
- System 2 –** Enclosure mounted connector to cable connector. 1 G ohm minimum insulation resistance. 1,000 V rms. Voltage proof.
- System 3 –** Cable to cable connection systems. 1 G ohm minimum insulation resistance. 1,000 V rms. Voltage proof.

- It is recommended that connectors be tested in the specific application.
- Service life of connectors cannot be predicted for all applications.

MATERIALS AND FINISHES:

- Connector Insert:** Nylon resin, UL 94V-0 black color.
Contacts: Precision machined copper alloy.
Contact Plating:
Corrosion Protection: Gold flash over nickel plate.
Corrosion Resistant: Gold plate 0.000030 inch [0.76 μ] over nickel plate.
- Shells, Jackscrew Systems and Cul-de-sac Mounting Accessories:**
Corrosion Protection: Steel, zinc plated with chromate seal.
Corrosion Resistant: Stainless steel passivated.
Push-on Fasteners: Phosphor bronze with tin plate.
Angle Brackets: Brass, zinc plate with chromate seal.
Hoods (Cable supports): Composite.
Interfacial Seal: Thermoplastic Elastomer (TPE), Santoprene™ or equivalent.
- Panel Mount Sealing Plate Assembly:** Glass filled thermoplastic with elastomer O-ring.
- Protective Cover Over Connector Shell:** Conductive polyethylene or conductive polyester.

MECHANICAL CHARACTERISTICS:

- Size 20 Fixed Contacts:** Male contact – 0.040 inch [1.02 mm] mating diameter. Female contact - rugged open entry design.
- Contact Retention in Connector insert:** 6 lbs. [27N]
- Resistance to Solder Iron Heat:** 500°F (260°C) for 10 seconds duration per IEC 60512-6.
- Contact Terminations:** Solder cup contacts – 0.042 inch [1.06 mm] minimum hole diameter for 20 AWG [0.5 mm²] wire maximum. Straight printed board mount – 0.028 inch [0.71 mm] termination diameter. Right angle (90°) printed board mount – 0.028 inch [0.71 mm] termination diameter for all printed board contact footprints. Trapezoidally shaped shells. Cul-de-sac blind hole fasteners, angle brackets and push-on fasteners.
- Coding (keying):** Trapezoidally shaped shells.
- Enclosure Mounting Accessories:** Cul-de-sac blind hole fasteners, angle brackets and push-on fasteners.
- Inside Wall Enclosure Mount:** Minimum thickness 0.040 inch [1.0 mm]. Maximum thickness 0.080 inch [2.0 mm].
- Locking Systems:** Jackscrews.
- Mechanical Operations:** 250 operations minimum per IEC 60512-5 IP67 immersion rated. 500 operations minimum per IEC 60512-5 IP65 spray nozzle rated.
- Required Sealing Plate Mounting Torque:** 1.75 in-lb. [0.20 Nm] minimum. 2.25 in-lb. [0.25 Nm] maximum.
- ELECTRICAL CHARACTERISTICS:**
- Contact Current Rating:** 7.5 amperes nominal.
Initial Contact Resistance: 0.008 ohms maximum.
Insulator Resistance: 5 G ohms.
Clearance and Creepage Distance Minimum: 0.039 inch [1.0mm].
Proof Voltage: 1000 V r.m.s.
Working Voltage: 300 V r.m.s.
- CLIMATIC CHARACTERISTICS:**
Temperature Range: -25°C to +85°C

Visit our web site for the latest catalog updates and supplements at
www.connectpositronic.com/connector-details/d-subminiature/environmentally-sealed/catalog

Do you need 2-D drawings or 3-D models?

Once you have made a connector selection, contact Technical Sales if you would like a 2-D drawing or 3-D model. If we do not have your specific part number on file, we can create one for you. Or, please visit www.connectpositronic.com and use the search function.

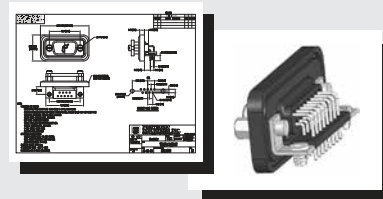

CONTACT VARIANTS *
FACE VIEW OF MALE

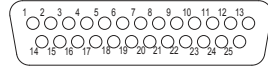

WD 25 *
Currently available with male contacts

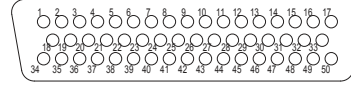

WD 50 *
Currently available with male contacts

* Contact variants for size 9, 15, 37, 25 (female) and 50 (female) are available in the **IMPROVED Unibody Design**. See page 11 for details.
For sealing plate dimensions see page 7.

SOLDER CUP TERMINATION
WITH ENCLOSURE WALL MOUNT SEALING PLATE
CODE 2

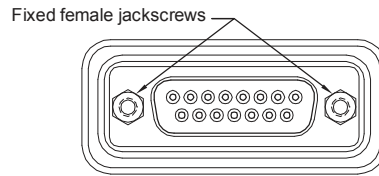
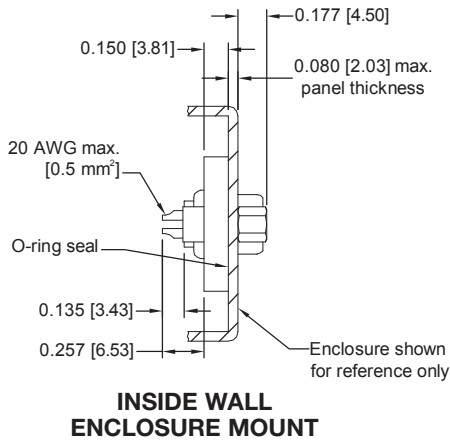

Typical part number:
WD9P2C5AT70

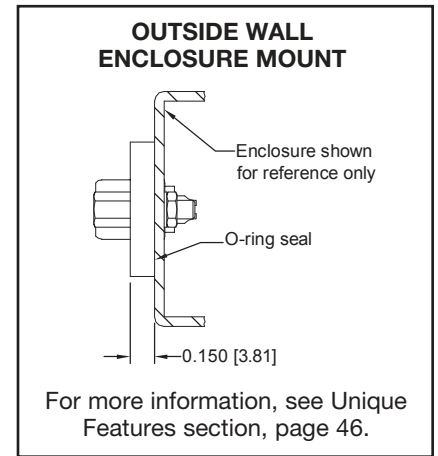

STRAIGHT SOLDER PRINTED BOARD MOUNT TERMINATION
WITH ENCLOSURE WALL MOUNT SEALING PLATE
CODE 3, 0.150 [3.81] CONTACT EXTENSION

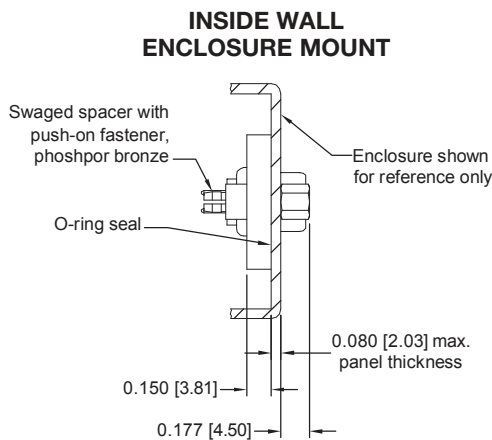

Typical part number:
WD15P3C8AT70

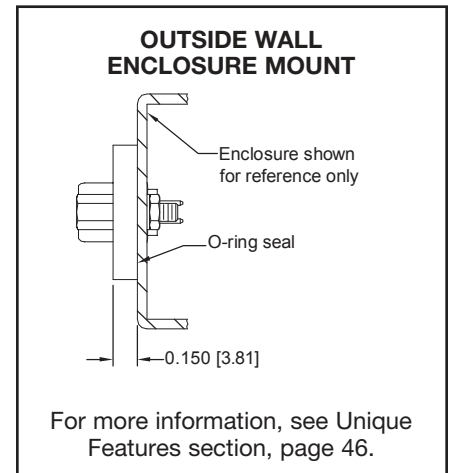
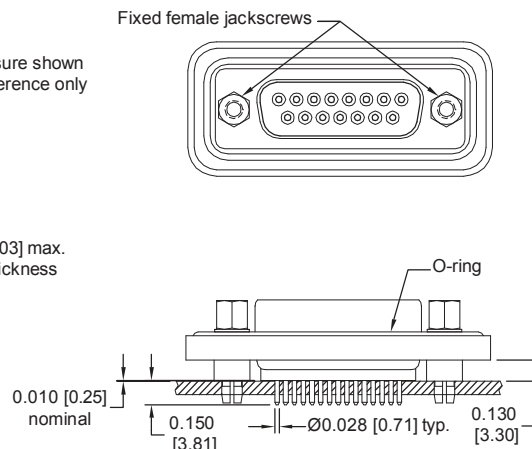



Positronic
connectpositronic.com

WD SERIES

PROFESSIONAL QUALITY
STANDARD DENSITY FIXED CONTACTS

Environmental
D-Sub

RIGHT ANGLE (90°) PRINTED BOARD MOUNT TERMINATION WITH ENCLOSURE MOUNT SEALING PLATE CODE 5, 0.188 [4.78] CONTACT EXTENSION

INSIDE WALL ENCLOSURE MOUNT

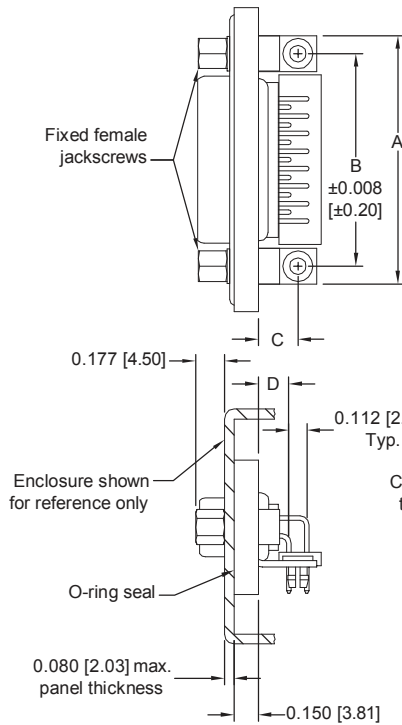

Typical part number:
WD25P5C7AT70

WD**5*** 0.188 [4.78] CONTACT EXTENSION				
PART NUMBER	A	B	C	D
WD25P5***	2.072 [52.63]	1.852 [47.04]	0.244 [6.20]	0.188 [4.78]
WD50P5***	2.626 [66.70]	2.406 [61.11]	0.300 [7.62]	0.188 [4.78]

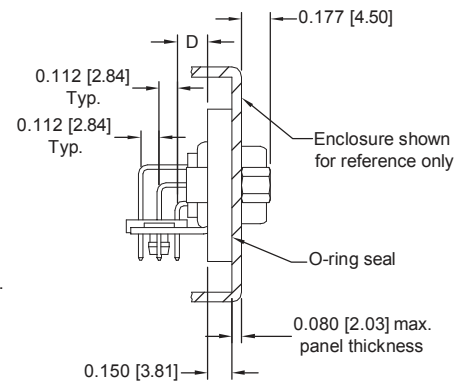
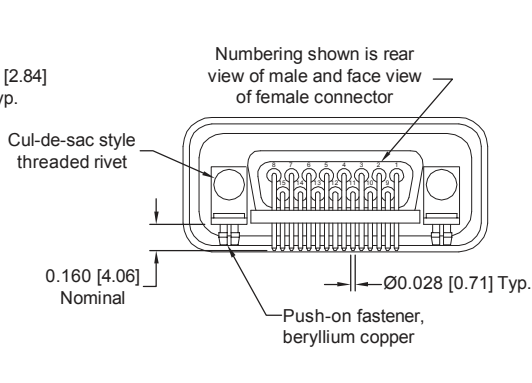

Typical part number:
WD50P5C7AT70

RIGHT ANGLE (90°) AND STRAIGHT PRINTED BOARD CONTACT HOLE PATTERN MOUNT CONNECTOR WITH MATING FACE POSITIONED TO FOLLOW DIRECTION OF THE ARROW.

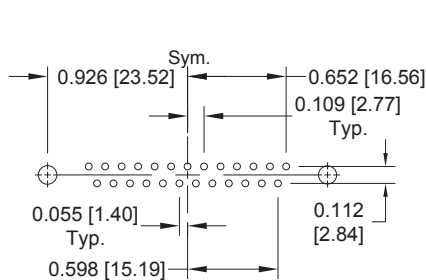

WD 25

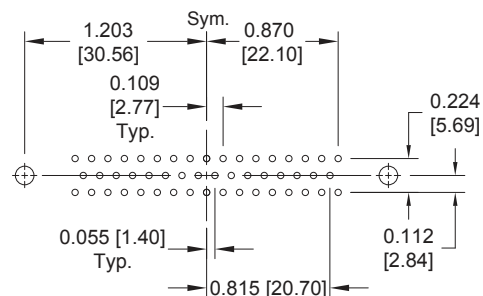

WD 50

SUGGESTED PRINTED BOARD HOLE SIZES:

Suggest 0.123 ±0.003 [3.12] Ø holes for mounting connector with push-on fasteners.
Suggest 0.045 [1.14] hole for contact termination positions.



ORDERING INFORMATION - CODE NUMBERING SYSTEM

Specify Complete Connector By Selecting An Option From Step 1 Through 8

† Contact variants for size 9, 15, 37, 25 (female) and 50 (female) have been **transitioned** to the preferred **Unibody** design. For WD Unibody Ordering Information, see page 13.

STEP	1	2	3	4	5	6	7	8	9	10
EXAMPLE	WD	25	P	2	C5	A	T7	S	/AA	
STEP 1 - BASIC SERIES WD Series										STEP 10 - SPECIAL OPTIONS CONTACT TECHNICAL SALES FOR SPECIAL OPTIONS
† STEP 2 - CONNECTOR VARIANTS † 25 - Male only. † 50 - Male only.										STEP 9 - ENVIRONMENTAL COMPLIANCE OPTIONS /AA - Compliant per EU Directive 2002/95/EC (RoHS) NOTE: If compliance to environmental legislation is not required, this step will not be used. Example: WD25P2C5AT7S
STEP 3 - CONNECTOR GENDER P - Male with interfacial seal F - Female										STEP 8 - SHELLS AND ACCESSORY OPTIONS 0 - Corrosion Protected Steel shells and jackscrews zinc plated with chromate seal. Contacts gold flash over nickel plate. S - Corrosion Resistant Stainless steel shells and jackscrews Contacts 0.000030 inch [0.76µ] gold plated over nickel.
STEP 4 - CONTACT TERMINATION TYPE 2 - Solder cup. 3 - Solder, straight printed board mount with 0.150 [3.81] tail length. 5 - Solder, right angle (90°) printed board mount, contact extension 0.188 [4.78].										STEP 7 - FEMALE FIXED JACKSCREWS T7 - Always used when ordering C5, C7 and C8 (step 5).
STEP 5 - CUL-DE-SAC STYLE MOUNTING ACCESSORIES C5 - Inside wall mounting for Code 2 and 3 (step 4) only. <i>Available for sizes: 25 male, and 50 male.</i> C7 - Inside wall mounting for Code 5 (step 4), right angle (90°) printed board mount only. Consists of an assembly of angle bracket, alignment bar and push-on fastener. <i>Available for sizes: 25 male, and 50 male.</i> C8 - Inside wall mounting for Code 3 (step 4) only. Includes push-on fastener. <i>Available for sizes: 25 male, and 50 male.</i>										STEP 6 - ENCLOSURE WALL MOUNT SEALING PLATE A - Inside wall enclosure mounted connector.
NOTE: For C9 outside wall mounting option, refer to Unique Features section, page 46.										

Do you need 2-D drawings or 3-D models?

See page 10 for more information



Positronic
connectpositronic.com

WDD SERIES

PROFESSIONAL QUALITY HIGH DENSITY FIXED CONTACTS

Environmental
D-Sub



- ✓ Popular, economical, high density option for applications requiring **sealed** connectors.
- ✓ Precision sealing process ensures environmental performance.
See page 6 for details.
- ✓ **Fixed**, size 22 contacts
- ✓ Terminations include solder cup, straight and right angle (90°) printed board mount.
- ✓ Five connector variants with 15, 26, 44, 62, and 78 contacts.
See WDD Unibody section (page 16) for variants supplied in Unibody design.
- ✓ Corrosion protected and corrosion resistant options.
- ✓ A wide variety of options and accessories.

Connectors Conforms to:

- IP67 per IEC 60529
- UL File # E49351
- CSA File # LR 54219

Telecommunication:

- UL File # E140980

TECHNICAL CHARACTERISTICS

ENVIRONMENTAL CHARACTERISTICS:

WIN-DD series connectors mounted on IEC 60529 or NEMA 250 enclosures for electrical equipment.

WIN-DD connector panel mount sealing plates, when mounted on the walls of enclosures, maintain the dust and water ingress protection rating of IEC 60529 or NEMA 250 enclosures on which they are mounted. WIN-DD connector-enclosure assemblies provide dust and water ingress protection to IP67 which allows temporary immersion in water to a depth of 0.5 meters for 30 minutes without ingress of water or dust to the enclosure. Refer to Appendix A for details of IP67 ratings and NEMA enclosure types 6 and 4X, as well as other enclosures having less stringent environmental requirements.

WIN-DD series cable connectors with cable support WIN-DD cable connectors meet the requirements of IEC 60807-2 Performance Level 2, where applicable, plus the ingress protection requirements of IP67 thereby maintaining the electrical integrity and the ingress protection level of the connection system.

ENVIRONMENTAL TEST SPECIFICATIONS

Applicable IEC Moisture Tests

IP65 IEC 60529 Test 14.2.5: Spray nozzle 6.3 mm diameter, delivery rate 12.5 liters per minute, 1 minute duration of connector exposure to spray. When conducting this test on System 1 – Portable Enclosure Connectors, the protective cover must be securely fastened over the face of the connector. **Requirements:** No water to have penetrated enclosure through connector.

IP67 IEC 60529 Test 14.2.7: Temporary immersion, 0.5 meters for 30 minutes. **Requirements:** No water to have penetrated enclosure through connector.

continued on next page. . . .



TECHNICAL CHARACTERISTICS, continued

continued from previous page. . . .

Applicable IEC Connector Tests After Moisture Exposure Tests Have Been Performed

IEC 60512-2, Test 3a: Insulation Resistance
IEC 60512-2, Test 4a: Voltage proof

Requirements:

- System 1** – Portable enclosure. 1 G ohm minimum insulation resistance after connector face and contacts are dried. Voltage proof 1,000 V rms.
- System 2** – Enclosure mounted connector to cable connector. 1 G ohm minimum insulation resistance. 1,000 V rms. Voltage proof.
- System 3** – Cable to cable connection systems. 1 G ohm minimum insulation resistance. 1,000 V rms. Voltage proof.
- It is recommended that connectors be tested in the specific application.
- Service life of connectors cannot be predicted for all applications.

MATERIALS AND FINISHES:

Connector insert: Glass filled polyester per ASTM D5927 , UL 94V-0, black color.
Contacts: Precision machined copper alloy.
Contact Plating:
Corrosion Protection: Gold flash over nickel plate.
Corrosion Resistant: Gold plate 0.000030 inch [0.76 μ] over nickel plate.

Shells, Jackscrew Systems and Cul-de-sac Mounting Accessories:
Corrosion Protection: Steel, zinc plated with chromate seal.
Corrosion Resistant: Stainless steel passivated.
Push-on Fasteners: Phosphor bronze with tin plate.
Angle Brackets: Brass, zinc plate with chromate seal.
Hoods (Cable supports): Composite.
Interfacial Seal: Thermoplastic Elastomer (TPE), Santoprene™ or equivalent.

Panel Mount Sealing Plate Assembly: Glass filled thermoplastic with elastomer O-ring.

Protective Cover Over Connector Shell: Conductive polyethylene or conductive polyester.

MECHANICAL CHARACTERISTICS:

Size 22 Fixed Contacts: Male contact – 0.030 inch [0.75 mm] mating diameter. Female contacts - rugged “Robi-D” open entry design. Closed entry design available, contact technical sales.

Contact Retention in Insulator: 9 lbs. [40N]

Resistance to Solder Iron Heat: 500°F [260°C] for 10 seconds duration per IEC 60512-6.

Contact Terminations: Solder cup contacts – 0.035 inch [0.89 mm] minimum hole diameter for 22 AWG [0.3 mm²] wire maximum.
Straight printed board mount – 0.020 inch [0.5 mm] termination diameter.
Right angle (90°) printed board mount - 0.030 inch [0.76 mm] termination diameter.
Trapezoidally shaped shells.
Cul-de-sac blind hole fasteners, angle brackets and push-on fasteners.
Minimum thickness 0.040 inch [1.0 mm].
Maximum thickness 0.080 inch [2.0 mm].
Jackscrews.
250 operations minimum per IEC 60512-5 IP67 immersion rated.
500 operations minimum per IEC 60512-5 IP65 spray nozzle rated.
1.75 in-lb. [0.20 Nm] minimum.
2.25 in-lb. [0.25 Nm] maximum.

Coding (keying):

Enclosure Mounting Accessories:
Inside Wall Enclosure Mount:
Locking Systems:
Mechanical Operations:

Required Sealing Plate Mounting Torque:

ELECTRICAL CHARACTERISTICS:
Contact Current Rating: 5 amperes nominal.
Initial Contact Resistance: 0.010 ohms maximum.
Insulator Resistance: 5 G ohms.
Clearance and Creepage Distance (minimum): 0.042 inch [1.06 mm].
Proof Voltage: 1000 V r.m.s.
Working Voltage: 300 V r.m.s.

CLIMATIC CHARACTERISTICS:
Temperature Range: -25°C to +85°C

Visit our web site for the latest catalog updates and supplements at www.connectpositronic.com/connector-details/d-subminiature/environmentally-sealed/catalog

Do you need 2-D drawings or 3-D models?

Once you have made a connector selection, contact Technical Sales if you would like a 2-D drawing or 3-D model. If we do not have your specific part number on file, we can create one for you. Or, please visit www.connectpositronic.com and use the search function.

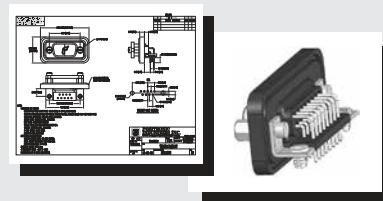



Positronic
connectpositronic.com

WDD SERIES

PROFESSIONAL QUALITY HIGH DENSITY FIXED CONTACTS

Environmental
D-Sub

CONTACT VARIANTS*

FACE VIEW OF MALE OR REAR VIEW OF FEMALE

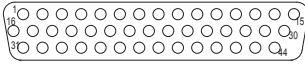

WDD 44

Currently available with male contacts.
For female contact variants,
see page 16.

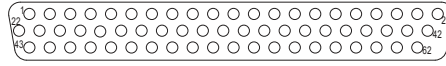

WDD 62

Currently available with male and female contacts.

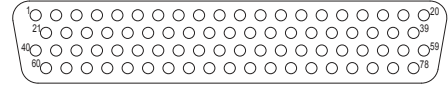

WDD 78

Currently available with male and female contacts.

* Contact variants for size 15, 26 and 44 (female) are available in the **IMPROVED Unibody design**. See page 16 for details.
For sealing plate dimensions see page 7.

SOLDER CUP TERMINATION

WITH ENCLOSURE WALL MOUNT SEALING PLATE

CODE 2

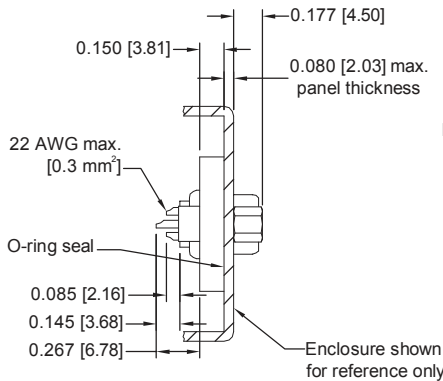

**INSIDE WALL
ENCLOSURE MOUNT**

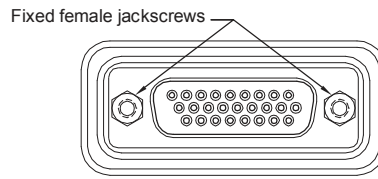

Typical part number:
WDD62F2C5AT70

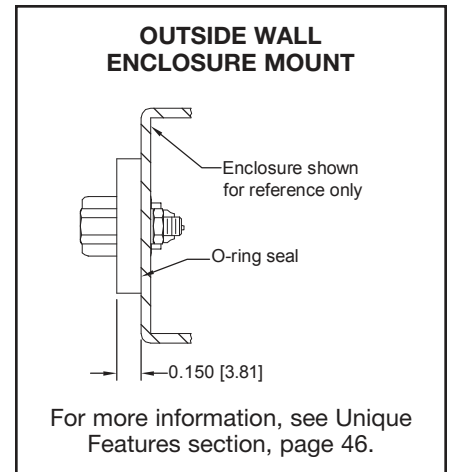

STRAIGHT SOLDER PRINTED BOARD MOUNT TERMINATION

WITH ENCLOSURE WALL MOUNT SEALING PLATE

CODE 3, 0.150 [3.81] CONTACT EXTENSION

**INSIDE WALL
ENCLOSURE MOUNT**

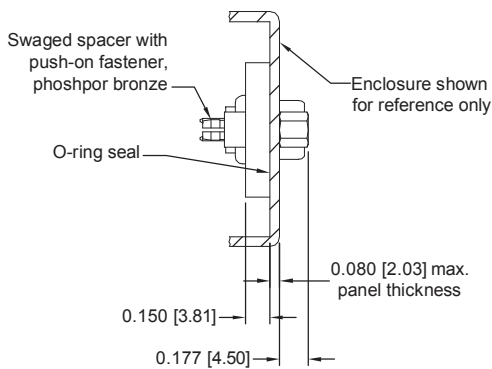

Typical part number:
WDD62F3C8AT70

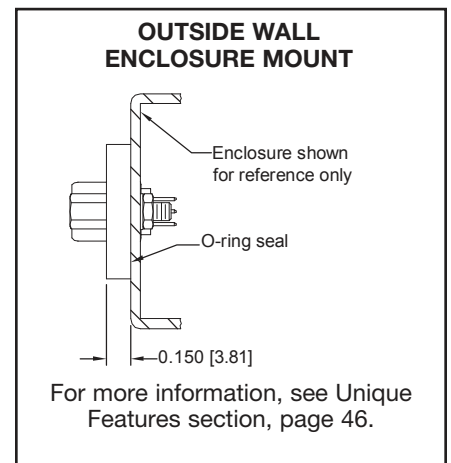
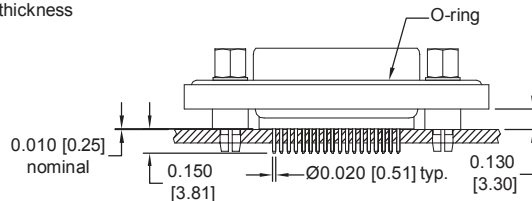
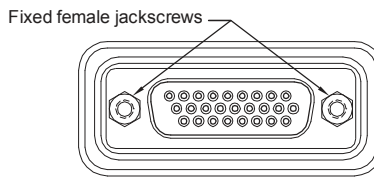

WDD SERIES



RIGHT ANGLE (90°) PRINTED BOARD MOUNT TERMINATION
WITH ENCLOSURE MOUNT SEALING PLATE
CODE 4, 0.219 [5.56] CONTACT EXTENSION

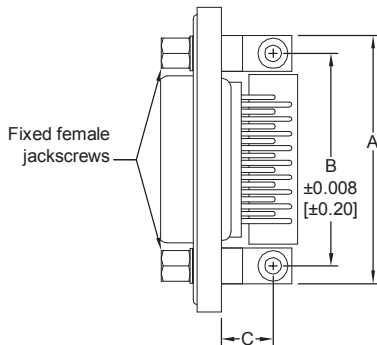

WDD**4**** 0.219 [5.56] CONTACT EXTENSION				
PART NUMBER	A	B	C	D
WDD44M4****	2.072 [52.63]	1.852 [47.04]	0.319 [8.10]	0.219 [5.56]
WDD62*4****	2.720 [69.09]	2.500 [63.50]	0.319 [8.10]	0.219 [5.56]
WDD78*4****	2.626 [66.70]	2.406 [61.11]	0.319 [8.10]	0.219 [5.56]

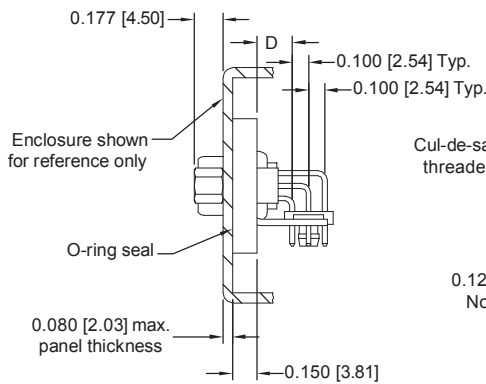

INSIDE WALL ENCLOSURE MOUNT

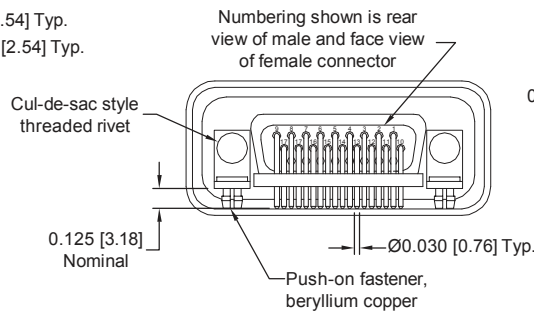

Typical part number:
WDD62P4C7AT70

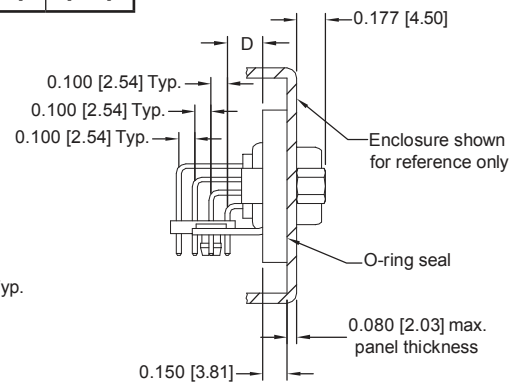

Typical part number:
WDD78P4C7AT70

RIGHT ANGLE (90°) AND STRAIGHT PRINTED BOARD CONTACT HOLE PATTERN
MOUNT CONNECTOR WITH MATING FACE POSITIONED TO FOLLOW DIRECTION OF ARROWS.

WDD44 MALE

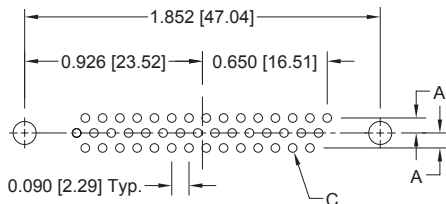

CODE NUMBER	A	B	C	D
3	0.078 [1.98]	0.082 [2.08]	0.035 [0.89]	0.123 [3.12]
4	0.100 [2.54]	0.100 [2.54]	0.045 [1.14]	0.100 [2.54]

WDD62 MALE

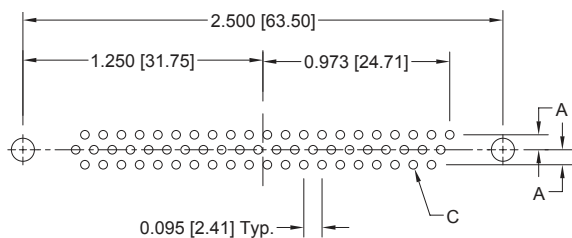

WDD62 FEMALE

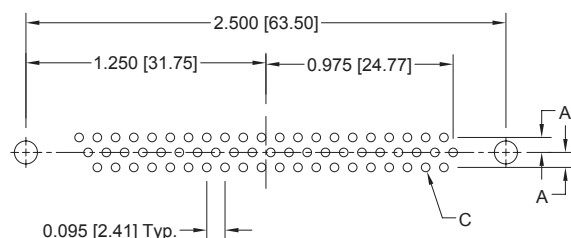

WDD78 MALE

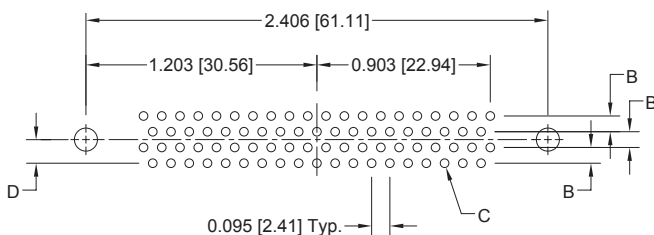

WDD78 FEMALE

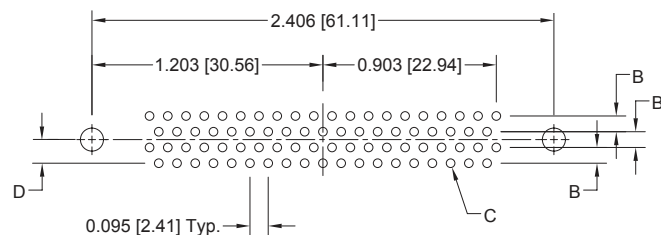

SUGGESTED PRINTED BOARD HOLE SIZES:

Suggest 0.123 ±0.003 [3.12] Ø holes for mounting connector with push-on fasteners

DIMENSIONS ARE IN INCHES [MILLIMETERS]. ALL DIMENSIONS ARE SUBJECT TO CHANGE.



ORDERING INFORMATION - CODE NUMBERING SYSTEM

Specify Complete Connector By Selecting An Option From Step 1 Through 8

† Contact variants for size 15, 26 and 44 (female) have been **transitioned** to the preferred **Unibody** design. For WDD Unibody Ordering Information, see page 18

STEP	1	2	3	4	5	6	7	8	9	10
EXAMPLE	WDD	62	F	2	C5	A	T7	S	/AA	
STEP 1 - BASIC SERIES WDD series										STEP 10 - SPECIAL OPTIONS CONTACT TECHNICAL SALES FOR SPECIAL OPTIONS
† STEP 2 - CONNECTOR VARIANTS † 44 - Male only. 62 - Male and Female 78 - Male and Female										STEP 9 - ENVIRONMENTAL COMPLIANCE OPTIONS /AA - Compliant per EU Directive 2002/95/EC (RoHS) NOTE: If compliance to environmental legislation is not required, this step will not be used. Example: WDD62F2C5AT7S
STEP 3 - CONNECTOR GENDER P - Male with interfacial seal F - Female										
STEP 4 - CONTACT TERMINATION TYPE 2 - Solder cup 3 - Solder, straight printed board mount with 0.150 [3.81] tail length. 4 - Solder, right angle (90°) printed board mount, contact extension 0.219 [5.56].										STEP 8 - SHELLS AND ACCESSORY OPTIONS 0 - Corrosion Protected Steel shells and jackscrews zinc plated with chromate seal. Contacts gold flash over nickel plate. S - Corrosion Resistant Stainless steel shells and jackscrews Contacts 0.000030 inch [0.76 μ] gold plated over nickel.
STEP 5 - CUL-DE-SAC STYLE MOUNTING ACCESSORIES C5 - Inside wall mounting for Code 2 and 3 (step 4) only. Available for sizes: 62 and 78. C7 - Inside wall mounting for Code 4 (step 4), right angle (90°) printed board mount only. Consists of an assembly of angle bracket, alignment bar and push-on fastener. Available for sizes: 62 and 78. C8 - Inside wall mounting for Code 3 (step 4) only. Includes push-on fastener. Available for sizes: 62 and 78. NOTE: For C9 outside wall mounting option, refer to Unique Features section, page 46.										STEP 7 - FEMALE FIXED JACKSCREWS T7 - Always used when ordering C5, C7 and C8 (step 5).
										STEP 6 - ENCLOSURE WALL MOUNT SEALING PLATE A - Inside wall enclosure mounted connector.

Do you need 2-D drawings or 3-D models?
See page 10 for more information

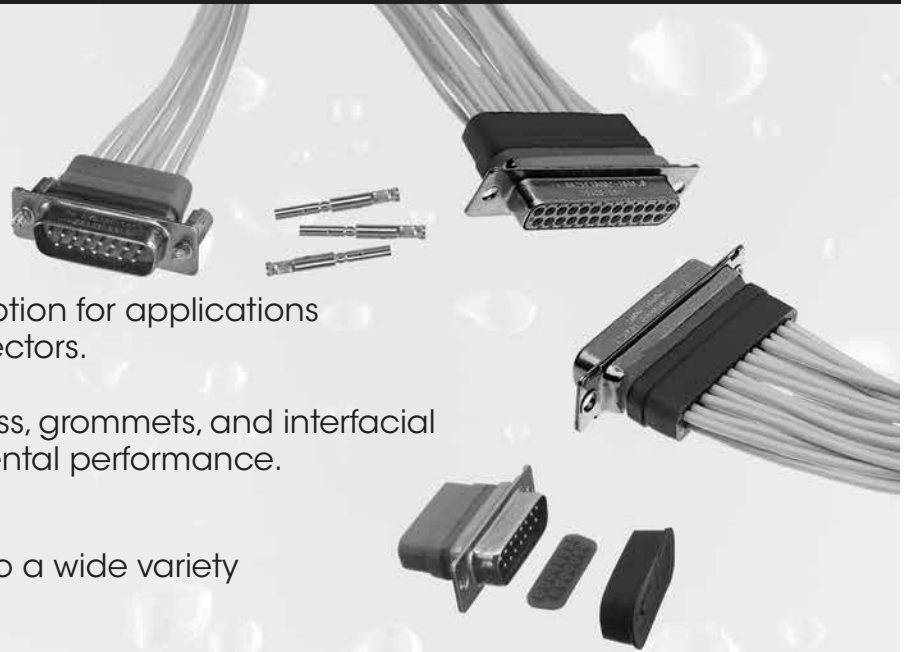

- ✓ Popular, economical option for applications requiring **sealed** connectors.
- ✓ Precision sealing process, grommets, and interfacial seals ensure environmental performance. *See page 38 for details.*
- ✓ Materials are resistant to a wide variety of harsh liquids.
- ✓ **Crimp removable**, size 20 contacts
- ✓ Five connector variants include 9, 15, 25, 37, and 50 contacts.
- ✓ Corrosion protected and corrosion resistant options.
- ✓ A wide variety of options and accessories.

Connectors Conforms to:

- IP 67 per IEC 60529
- Performance conforms to applicable requirements of MIL-DTL-24308 and SAE AS39029

EVD SERIES

T E C H N I C A L C H A R A C T E R I S T I C S

ENVIRONMENTAL CHARACTERISTICS:

EVD connectors, having crimp contacts, meet all of the applicable requirements of MIL-DTL-24308 in addition to the requirements shown below:

<p>Test IP67</p>	<p>Requirements Temporary immersion, 0.5 meters for 30 minutes. Mated condition. No water to have penetrated enclosure through connector.</p>
<p>Humidity per EIA 364-31 method IV, Method 1002.2, Type II</p>	<p>1) No deterioration of performance. 2) Insulation resistance greater than 100 mega ohms. 3) Withstand a potential of 1000 VAC (rms) without evidence of flashover or breakdown.</p>
<p>Fluid Immersion per ANSI/EIA-364-10 Test Conditions A and D</p>	<p>1) No detrimental damage. 2) Meet mating and unmating requirements of MIL-DTL-24308.</p>

Immersion, 2 hours at a depth of 36 inch [914.4 mm] in mated condition per MIL-STD 810 Method 512.3. Procedure 1.

While Immersed:
1) Insulation resistance greater than 100 mega ohms.
2) Withstand a potential of 1000 VAC (rms) without evidence of flashover or breakdown.

MATERIALS AND FINISHES:

<p>Connector Insert:</p>	<p>Glass-filled DAP per ASTM-D-5948 type SDG-F, UL 94V-0, green color.</p>
<p>Contacts:</p>	<p>Precision machined cooper alloy.</p>
<p>Contact Plating:</p>	<p>Military performance - 0.000050 inch [1.27 µ] gold over nickle plate. Industrial performance - 0.000030 inch [0.76 µ] gold over nickel.</p>
<p>Shells:</p>	<p>Steel with zinc plate with chromate seal and stainless steel, passivated.</p>



Positronic
connectpositronic.com

EVD SERIES

MILITARY / INDUSTRIAL QUALITY
FOR MILITARY AND SEVERE INDUSTRIAL ENVIRONMENTAL APPLICATIONS
STANDARD DENSITY REMOVABLE CONTACTS

Environmental
D-Sub

TECHNICAL CHARACTERISTICS, continued

continued from previous page. . . .

Mounting Spacers:	Steel or brass, zinc plate with chromate seal.
Jackscrew Systems:	Steel with zinc plate and chromate seal; and stainless steel, passivated.
Hoods:	Composite.
Grommet and Interfacial Seal:	Fluorosilicone Rubber per MIL-DTL-25988.
Bonding Material:	Fluorosilicone based sealant/adhesive.
Protective Cover Over Connector Shell:	Conductive polyethylene or conductive polyester.
Sealing Plug:	Teflon.

MECHANICAL CHARACTERISTICS:

Size 20 Removable Contacts:	Install contact to rear face of connector insert and release from rear face of connector insert. Male - 0.040 inch [1.02 mm] diameter. Female - PosiBand closed entry design
Contact Retention in Insulator:	9 lbs. [40 N].
Contact Terminations:	Closed barrel crimp, wire sizes 20 AWG [0.5 mm ²] through 24 AWG [0.25 mm ²]; Solder contacts - 0.042 inch [1.06 mm] minimum hole diameter for 20 AWG [0.5 mm ²] through 24 AWG [0.25 mm ²] wire size.
Coding (keying):	Trapezoidally shaped shells.
Locking Systems:	Jackscrews.
Mechanical Operations:	500 operations minimum per IEC 60512-5.

ELECTRICAL CHARACTERISTICS:

Dry Conditions, Basic Connector Body:	
Contact Current Rating, Tested per UL 1977:	18 amperes, 2 contacts energized. 14 amperes, 6 contacts energized. 11 amperes, 15 contacts energized. 10 amperes, 25 contacts energized. 9 amperes, 50 contacts energized.
Visit http://www.connectpositronic.com/connector-details/d-subminiature/environmentally-sealed/technical-specifications/ to view temperature rise curves.	
Initial Contact Resistance:	0.004 ohms maximum.
Proof Voltage:	1,000 V r.m.s.
Insulation Resistance:	5 G ohms.
Clearance and Creepage Distance (minimum):	0.039 inch [1.0 mm].
Working Voltage:	300 V r.m.s.

CLIMATIC CHARACTERISTICS:

Temperature Range:	-55°C to +125°C.
---------------------------	------------------

THERMOCOUPLE CONTACTS:

Size 20 crimp contacts are available, see page 40 for details.

Visit our web site for the latest catalog updates and supplements at www.connectpositronic.com/connector-details/d-subminiature/environmentally-sealed/catalog

CONTACT VARIANTS

FACE VIEW OF MALE OR REAR VIEW OF FEMALE

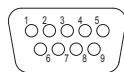

EVD 9

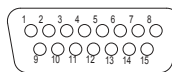

EVD 15

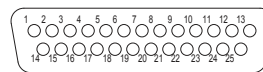

EVD 25

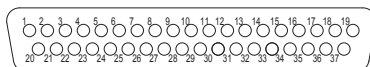

EVD 37

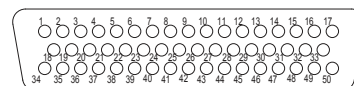

EVD 50

For information regarding **REMOVABLE CONTACTS**, see illustration/drawing and charts on pages 39 & 40.



STANDARD SHELL ASSEMBLY

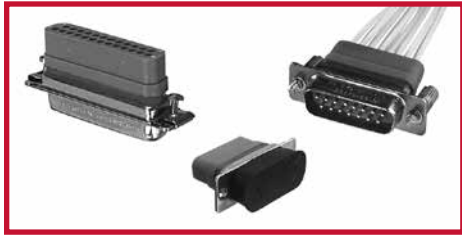

EVD25P000E20 (upper left), **EVD15P00000** (middle) and **EVD15P1000** (upper right).

RECOMMENDED MATING DIMENSIONS

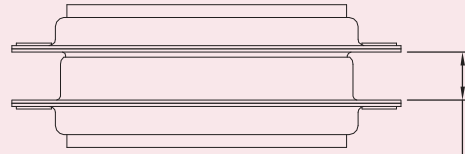

Shell Sizes 1 & 2 =
0.265±0.015 [6.73±0.38]
Shell Sizes 3, 4, 5 & 6 =
0.256±0.015 [6.50±0.38]

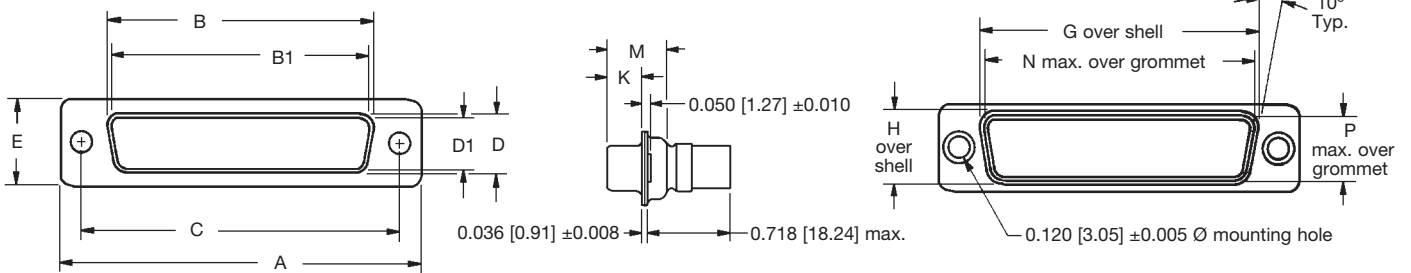

OPTIONAL SHELL ASSEMBLY (0)

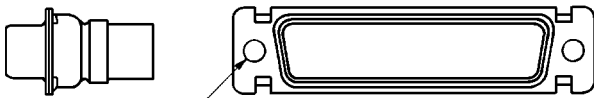

Ø0.120±0.005 [3.05±0.13]
Mounting hole, two places for stainless steel shell (0 option)

OPTIONAL SHELL ASSEMBLY WITH UNIVERSAL FLOAT MOUNTS (F)

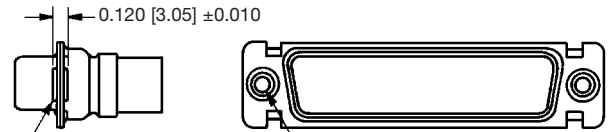

0.032 [0.81] Total diametral float
0.086 [2.18] +0.005-0.000 Mounting hole, two places

CONNECTOR VARIANT SIZES	GENDER	A	B	B1	C	D	D1	E	G	H	K	M
		±0.015 [0.38]	±0.005 [0.13]	±0.005 [0.13]	±0.005 [0.13]	±0.005 [0.13]	±0.005 [0.13]	±0.005 [0.13]	±0.015 [0.38]	±0.010 [0.25]	±0.010 [0.25]	±0.005 [0.13]
EVD 9 (SHELL SIZE 1)	MALE	1.213 [30.81]		0.666 [16.92]	0.984 [24.99]		0.329 [8.36]	0.494 [12.55]	0.759 [19.28]	0.422 [10.72]	0.233 [5.92]	0.422 [10.72]
	FEMALE	1.213 [30.81]	0.643 [16.33]		0.984 [24.99]	0.311 [7.90]		0.494 [12.55]	0.759 [19.28]	0.422 [10.72]	0.243 [6.17]	0.429 [10.90]
EVD 15 (SHELL SIZE 2)	MALE	1.541 [39.14]		0.994 [25.25]	1.312 [33.32]		0.329 [8.36]	0.494 [12.55]	1.083 [27.51]	0.422 [10.72]	0.233 [5.92]	0.422 [10.72]
	FEMALE	1.541 [39.14]	0.971 [24.66]		1.312 [33.32]	0.311 [7.90]		0.494 [12.55]	1.083 [27.51]	0.422 [10.72]	0.243 [6.17]	0.429 [10.90]
EVD 25 (SHELL SIZE 3)	MALE	2.088 [53.04]		1.534 [38.96]	1.852 [47.04]		0.329 [8.36]	0.494 [12.55]	1.625 [41.28]	0.422 [10.72]	0.230 [5.84]	0.426 [10.82]
	FEMALE	2.088 [53.04]	1.511 [38.38]		1.852 [47.04]	0.311 [7.90]		0.494 [12.55]	1.625 [41.28]	0.422 [10.72]	0.243 [6.17]	0.429 [10.90]
EVD 37 (SHELL SIZE 4)	MALE	2.729 [69.32]		2.182 [55.42]	2.500 [63.50]		0.329 [8.36]	0.494 [12.55]	2.272 [57.71]	0.422 [10.72]	0.230 [5.84]	0.426 [10.82]
	FEMALE	2.729 [69.32]	2.159 [54.84]		2.500 [63.50]	0.311 [7.90]		0.494 [12.55]	2.272 [57.71]	0.422 [10.72]	0.243 [6.17]	0.429 [10.90]
EVD 50 (SHELL SIZE 5)	MALE	2.635 [66.93]		2.079 [52.81]	2.406 [61.11]		0.441 [11.20]	0.605 [15.37]	2.178 [55.32]	0.534 [13.56]	0.230 [5.84]	0.426 [10.82]
	FEMALE	2.635 [66.93]	2.064 [52.43]		2.406 [61.11]	0.423 [10.74]		0.605 [15.37]	2.178 [55.32]	0.534 [13.56]	0.243 [6.17]	0.429 [10.90]



Positronic
connectpositronic.com

EVD SERIES

MILITARY / INDUSTRIAL QUALITY
FOR MILITARY AND SEVERE INDUSTRIAL ENVIRONMENTAL APPLICATIONS
STANDARD DENSITY REMOVABLE CONTACTS

Environmental
D-Sub

EVD SERIES DESIGN ENVIRONMENTAL SEALING FEATURES

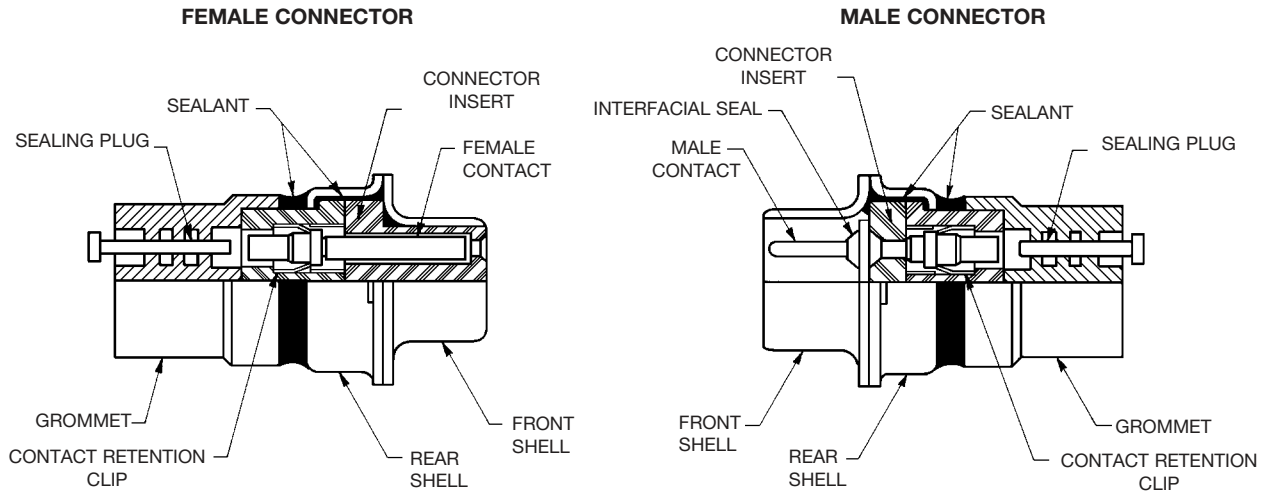

SEALING PLUG

ORDER SEPARATELY, PART NUMBER 4737-37-0-0



INTERFACIAL SEALS AND REAR GROMMETS

FOR USE WITH EVD SERIES

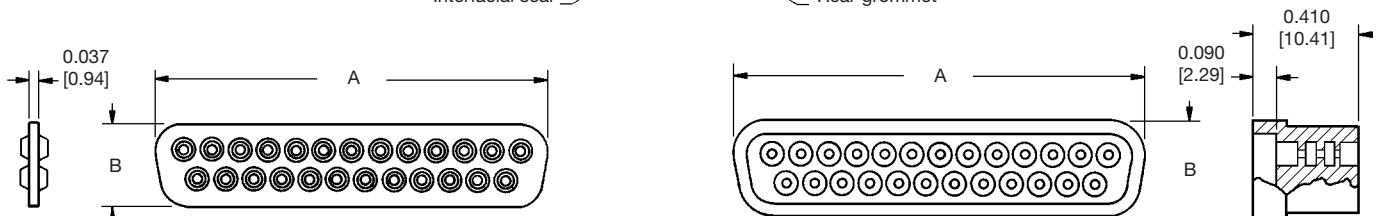
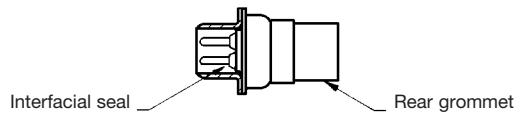

INTERFACIAL SEAL		
CONNECTOR VARIANT	A	B
9	0.650 [16.51]	0.318 [8.08]
15	0.978 [24.84]	0.318 [8.08]
25	1.513 [38.43]	0.318 [8.08]
37	2.156 [54.76]	0.318 [8.08]
50	2.058 [52.27]	0.425 [10.80]

REAR GROMMET		
CONNECTOR VARIANT	A	B
9	0.725 [18.42]	0.375 [9.53]
15	1.051 [26.70]	0.375 [9.53]
25	1.595 [40.51]	0.375 [9.53]
37	2.247 [57.07]	0.375 [9.53]
50	2.147 [54.53]	0.490 [12.45]

Material: Fluorosilicone and silicone blend.
Contact technical sales for ordering information.



MILITARY LEVEL REMOVABLE CRIMP CONTACT
FOR USE WITH EVD SERIES CONNECTORS

SIZE 20

Note: Connectors can be kitted with all applicable crimp contacts, contact Technical Sales for connector part number.

***MILITARY SPECIFICATION CONTACTS**

STANDARD FINISH:
0.000050 inch [1.27µ] gold over nickel

COLOR CODE:
MALE CONTACT:
ORANGE/BLUE/WHITE
FEMALE CONTACT:
ORANGE/BLUE/GRAY

FEMALE CONTACT
"CLOSED ENTRY" DESIGN

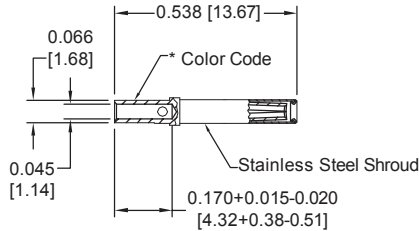

FEMALE PART NUMBER	WIRE SIZE AWG/[mm ²]
*M39029/63-368	20 / 22 / 24 [0.5/0.3/0.25]

MALE CONTACT

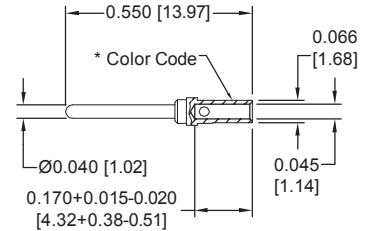

MALE PART NUMBER	WIRE SIZE AWG/[mm ²]
*M39029/64-369	20 / 22 / 24 [0.5/0.3/0.25]



INDUSTRIAL / MILITARY LEVEL REMOVABLE CRIMP CONTACT
FOR USE WITH EVD SERIES CONNECTORS

SIZE 20



Note: Connectors can be kitted with all applicable crimp contacts, contact Technical Sales for connector part number.

FEMALE CONTACT
"CLOSED ENTRY" DESIGN

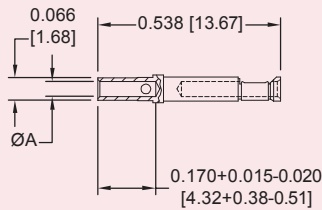

FEMALE PART NUMBER	WIRE SIZE AWG/[mm ²]	ØA
FC6020D2-14	20 / 22 / 24 [0.5/0.3/0.25]	0.045 [1.14]

MALE CONTACT

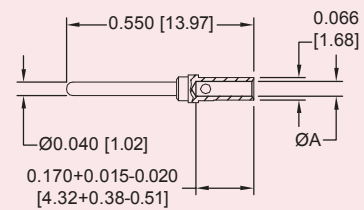

MALE PART NUMBER	WIRE SIZE AWG/[mm ²]	ØA
MC6020D-14	20 / 22 / 24 [0.5/0.3/0.25]	0.045 [1.14]

PROFESSIONAL LEVEL REMOVABLE CRIMP CONTACT
FOR USE WITH EVD SERIES CONNECTORS

SIZE 20

FEMALE CONTACT
"ROBI-D" OPEN ENTRY DESIGN

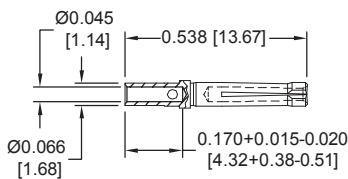

FEMALE PART NUMBER	WIRE SIZE AWG/[mm ²]
FC6520D-14	20 / 22 / 24 [0.5/0.3/0.25]

Note: Connectors can be kitted with all applicable crimp contacts, contact Technical Sales for connector part number.

For information regarding **CRIMP TOOL AND CRIMPING TOOL TECHNIQUES**, see page 47.



Positronic
connectpositronic.com

EVD SERIES

MILITARY / INDUSTRIAL QUALITY
FOR MILITARY AND SEVERE INDUSTRIAL ENVIRONMENTAL APPLICATIONS
STANDARD DENSITY REMOVABLE CONTACTS

Environmental
D-Sub



REMOVABLE THERMOCOUPLE CRIMP CONTACT

FOR USE WITH EVD SERIES CONNECTORS

SIZE 20

Note: Connectors can be kitted with all applicable crimp contacts, contact Technical Sales for connector part number.



FEMALE CONTACT
"CLOSED ENTRY" DESIGN

MALE CONTACT

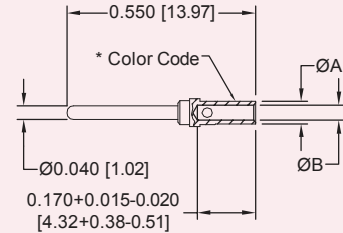
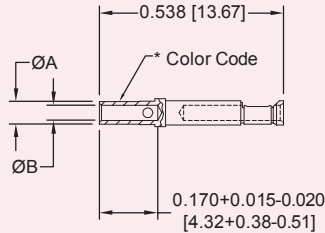

TYPE	MATERIAL	FEMALE PART NUMBER	MALE PART NUMBER	COLOR CODE	WIRE SIZE AWG [mm ²]	ØA	ØB
K	CHROMEL (+)	FC6020D2CH ^{††}	MC6020DCH [†]	WHITE	20 / 22 / 24 [0.5 / 0.3 / 0.25]	0.066 [1.68]	0.045 [1.14]
	ALUMEL (-)	FC6020D2AL ^{††}	MC6020DAL [†]	GREEN	20 / 22 / 24 [0.5 / 0.3 / 0.25]	0.066 [1.68]	0.045 [1.14]
T	COPPER (+)	FC6020D2CU ^{††}	MC6020DCU [†]	RED	20 / 22 / 24 [0.5 / 0.3 / 0.25]	0.066 [1.68]	0.045 [1.14]
	CONSTANTAN (-)	FC6020D2CO ^{††}	MC6020DCO [†]	YELLOW	20 / 22 / 24 [0.5 / 0.3 / 0.25]	0.066 [1.68]	0.045 [1.14]
E	CHROMEL (+)	FC6020D2CH ^{††}	MC6020DCH [†]	WHITE	20 / 22 / 24 [0.5 / 0.3 / 0.25]	0.066 [1.68]	0.045 [1.14]
	CONSTANTAN (-)	FC6020D2CO ^{††}	MC6020DCO [†]	YELLOW	20 / 22 / 24 [0.5 / 0.3 / 0.25]	0.066 [1.68]	0.045 [1.14]

For more information on the availability of Type J thermocouple contacts, and information about thermocouple contacts with printed circuit board solder termination, please contact Technical Sales.

Chromel[®] and Alumel[®] are registered trademarks of Hoskins Manufacturing Company.

[†]Dimensionally equivalent to M39029/64-369

^{††}Dimensionally equivalent to M39029/63-368

For information regarding **CRIMP TOOL AND CRIMPING TOOL TECHNIQUES**, see page 47.

EVD SERIES



ORDERING INFORMATION - CODE NUMBERING SYSTEM

Specify Complete Connector By Selecting An Option From Step 1 Through 8

STEP	1	2	3	4	5	6	7	8	9	10
EXAMPLE	EVD	25	P	1	0	Z	0	S	/AA	
STEP 1 - BASIC SERIES EVD Series										STEP 10 - SPECIAL OPTIONS Consult Technical Sales
STEP 2 - EVD Connector Variants 9, 15, 25, 37, 50										STEP 9 - ENVIRONMENTAL COMPLIANCE OPTIONS /AA - Compliant per EU Directive 2002/95/EC (RoHS) NOTE: If compliance to environmental legislation is not required, this step will not be used. Example: EVD25P10Z0S
STEP 3 - CONNECTOR GENDER P - Male with interfacial seal S - Female - PosiBand closed entry contact design										STEP 8 - SHELL OPTIONS *2S - Stainless steel, passivated. 0 - Zinc plated with chromate seal.
STEP 4 - Type of Contacts 0 - Contacts ordered separately. See pages 39 & 40 . 1 - Crimp, 20 AWG - 24 AWG [0.5 mm ² - 0.25 mm ²] kitted with connector. 2 - Solder, 20 AWG - 24 AWG [0.5 mm ² - 0.25 mm ²] kitted with connector.										*1 STEP 7 - LOCKING SYSTEMS 0 - None. Use only with 'Z' or 'Z4' (step 6). T2 - Fixed female jackscrews. E - Rotating male jackscrews.
*1 STEP 5 - MOUNTING STYLE 0 - Mounting hole, 0.120 [3.05] diameter. F - Float mounts, universal. S2 - Swaged spacer, 4-40 threads, 0.125 [3.18] length. S5 - Swaged locknut, 4-40 threads.										*1 STEP 6 - HOODS 0 - None. Z - Composite hood with rotating male jackscrews. Z4 - Composite hood with fixed female jackscrews.

NOTES:

- *1 For additional information listed in Steps 5, 6, and 7, see the Accessories section, page 42.
- *2 For stainless steel dimpled male versions, contact Technical Sales.

For information regarding **REMOVABLE CONTACTS**, see illustration/drawing and charts on pages 39 & 40 .

Do you need 2-D drawings or 3-D models?

Once you have made a connector selection, contact Technical Sales if you would like a 2-D drawing or 3-D model. If we do not have your specific part number on file, we can create one for you. Or, please visit www.connectpositronic.com and use the search function.

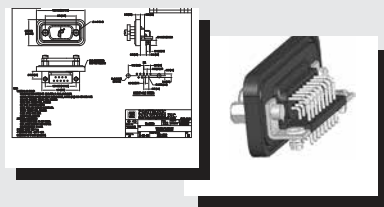



Positronic
connectpositronic.com



ACCESSORIES

Environmental
D-Sub

CUL-DE-SAC STYLE MOUNTING ACCESSORIES

FOR USE WITH WD AND WDD SERIES

CODE C5, C7 AND C8 (STEP 5)

INSIDE WALL

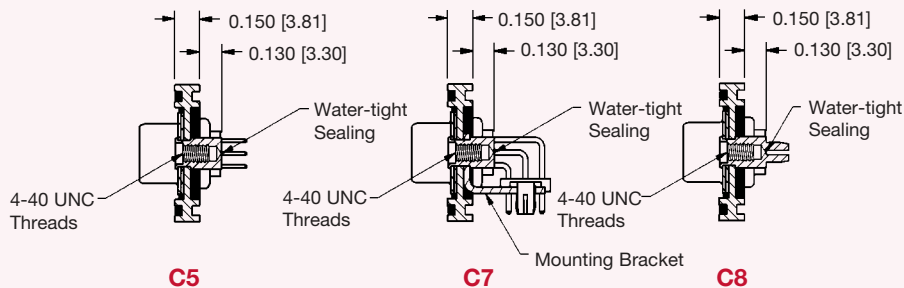

C5

STEEL, ZINC PLATE
WITH CHROMATE SEAL
OR STAINLESS STEEL,
PASSIVATED

C7

STEEL, ZINC PLATE
WITH CHROMATE SEAL,
OR STAINLESS STEEL,
PASSIVATED

C8

PHOSPHOR BRONZE,
TIN PLATE

OUTSIDE WALL ENCLOSURE MOUNT

Not available in Unibody design.
See Unique Feature
section, page 46.

ENCLOSURE WALL MOUNT SEALING PLATE

FOR USE WITH WD AND WDD SERIES

CODE A (STEP 6)

INSIDE WALL ENCLOSURE MOUNT

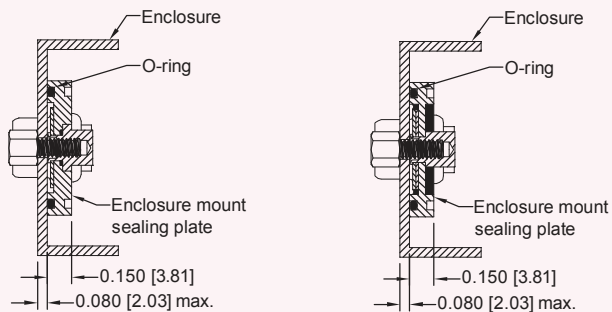

UNIBODY DESIGN

LEGACY DESIGN

OUTSIDE WALL ENCLOSURE MOUNT

Not available in Unibody design.
See Unique Feature
section, page 46.

Sealing Plate Material:

Glass filled thermoplastic

Note: Sealing plate is mounted to enclosure wall with jackscrews torqued to a value of 1.75 in-lb [0.20 Nm] minimum, 2.25 in-lb [0.25 Nm] maximum.

CONNECTOR VARIANT		A	B
WD	WDD		
9	15	0.67 [17.02]	0.34 [8.64]
15	26	1.00 [25.40]	0.34 [8.64]
25	44	1.53 [38.86]	0.34 [8.64]
37	62	2.18 [55.37]	0.34 [8.64]
50	78	2.08 [52.83]	0.45 [11.43]

INTERFACIAL SEAL

FOR USE WITH WD, AND WDD SERIES*
FURNISHED ON ALL MALE CONNECTORS

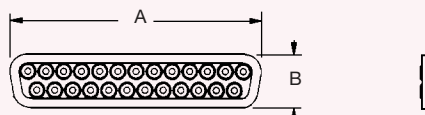

Material: Thermoplastic Elastomer (TPE), Santoprene™ or equivalent.

*NOTE:

For information on the interfacial seal supplied with EVD Series, see page 38.



COMPOSITE HOODS
FOR USE WITH WD, WDD OR EVD SERIES
CODE Z OR Z4 (STEP 6)

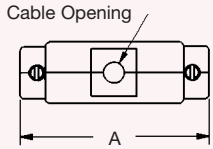

CODE Z: Composite hood with rotating male jackscrews.

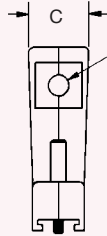
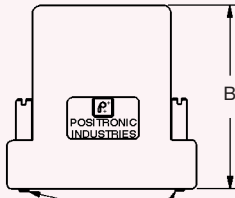

Cable Opening
(Side cable opening not available for size 50 hood)

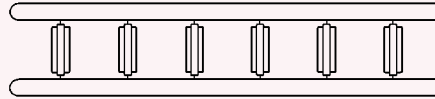

Insert Tree Assembly

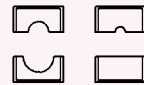

Typical Inserts

Various inserts are provided to accommodate different cable sizes

Typical part number:
D25000Z00

Rotating Male Jackscrews
4-40 UNC Threads, Steel, Zinc plated or Stainless Steel, passivated

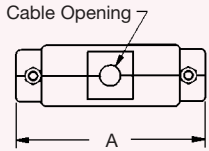

CODE Z4: Composite hood with fixed female jackscrews.

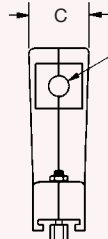
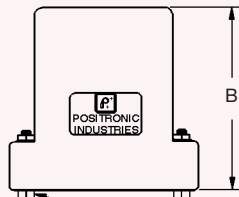

Cable Opening
(Side cable opening not available for size 50 hood)

Typical part number:
D25000Z400

Fixed Female Jackscrews
4-40 UNC Threads, Steel, Zinc plated or Stainless Steel, passivated

PART NUMBER	A	B	C	Cable Opening	
				MIN.	MAXIMUM
D9000Z00 D9000Z400	1.387 [35.23]	1.935 [49.15]	0.735 [18.67]	0.100 [2.54]	0.400 x 0.570 [10.16] x [14.48]
D15000Z00 D15000Z400	1.715 [43.56]	1.935 [49.15]	0.735 [18.67]	0.100 [2.54]	0.400 x 0.570 [10.16] x [14.48]
D25000Z00 D25000Z400	2.254 [57.25]	2.200 [55.88]	0.735 [18.67]	0.100 [2.54]	0.550 x 0.570 [13.97] x [14.48]
D37000Z00 D37000Z400	2.903 [73.74]	2.200 [55.88]	0.735 [18.67]	0.100 [2.54]	0.550 x 0.570 [13.97] x [14.48]
D50000Z00 D50000Z400	2.809 [71.35]	2.700 [68.58]	0.900 [22.86]	0.100 [2.54]	Ø 0.630 [16.00]

Material: Composite, conductive volume resistivity [1.0 OHM-cm max]. Alternate material: Glass filled nylon, UL 94V-0.

Attenuation: 40+ decibels



ENCLOSURE WALL CUTOUT FOR CONNECTORS

WD SERIES AND WDD SERIES

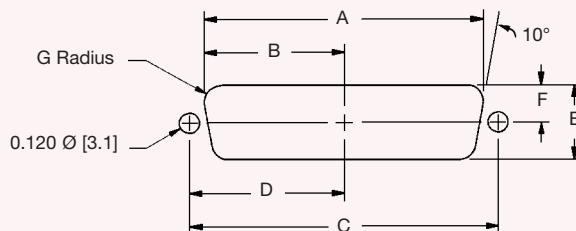

SHELL SIZE	WD	WDD	MOUNTING	A ±0.005	B ±0.005	C ±0.005	D ±0.005	E ±0.005	F ±0.005	G ±0.002
1	9	15	Inside Wall	0.806 [20.47]	0.403 [10.24]	0.984 [24.99]	0.492 [12.50]	0.449 [11.40]	0.225 [5.72]	0.132 [3.35]
			Outside Wall	0.874 [22.20]	0.437 [11.10]	0.984 [24.99]	0.492 [12.50]	0.513 [13.03]	0.257 [6.53]	0.083 [2.11]
2	15	26	Inside Wall	1.134 [28.80]	0.567 [14.40]	1.312 [33.32]	0.656 [16.66]	0.449 [11.40]	0.225 [5.72]	0.132 [3.35]
			Outside Wall	1.202 [30.53]	0.601 [15.27]	1.312 [33.32]	0.656 [16.66]	0.513 [13.03]	0.257 [6.53]	0.083 [2.11]
3	25	44	Inside Wall	1.674 [42.52]	0.837 [21.26]	1.852 [47.04]	0.926 [23.52]	0.449 [11.40]	0.225 [5.72]	0.132 [3.35]
			Outside Wall	1.743 [44.27]	0.872 [22.15]	1.852 [47.04]	0.926 [23.52]	0.513 [13.03]	0.257 [6.53]	0.083 [2.11]
4	37	62	Inside Wall	2.326 [59.08]	1.163 [29.54]	2.500 [63.50]	1.250 [31.75]	0.449 [11.40]	0.225 [5.72]	0.132 [3.35]
			Outside Wall	2.391 [60.73]	1.196 [30.38]	2.500 [63.50]	1.250 [31.75]	0.513 [13.03]	0.257 [6.53]	0.083 [2.11]
5	50	78	Inside Wall	2.218 [56.34]	1.109 [28.17]	2.406 [61.11]	1.203 [30.57]	0.555 [14.10]	0.278 [7.06]	0.132 [3.35]
			Outside Wall	2.297 [58.34]	1.149 [29.18]	2.406 [61.11]	1.203 [30.57]	0.623 [15.82]	0.312 [7.92]	0.083 [2.11]

PROTECTIVE COVER

SUPPLIED AS STANDARD WITH ALL CONNECTORS
WD, WDD AND EVD SERIES

COVER WITHOUT EARS

(FOR CONNECTORS WITHOUT FIXED JACKSCREWS)

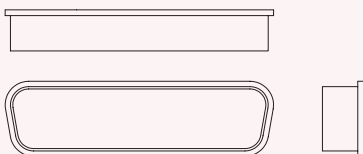

Material: Conductive polyethylene
Color: Black
Optional:
Material: Static dissipative ethylene vinyl acetate
Optional: Pink

COVER WITH EARS

(FOR CONNECTORS WITH FIXED JACKSCREWS)

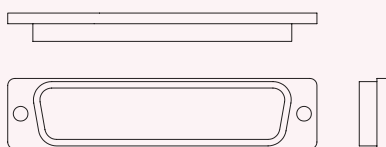

Material: Conductive polyester
Color: Black

WD EVD	WDD	CONDUCTIVE REPLACEMENT PART NUMBER WITHOUT EARS	STATIC DISSIPATIVE REPLACEMENT PART NUMBER WITHOUT EARS	REPLACEMENT PART NUMBER WITH EARS
9M	15M	4931-9-0-0	4931-9-1-0	4931-9-100-0
9F	15F	4932-9-0-0	4932-9-1-0	4932-9-100-0
15M	26M	4931-15-0-0	4931-15-1-0	4931-15-100-0
15F	26F	4932-15-0-0	4932-15-1-0	4932-15-100-0
25M	44M	4931-25-0-0	4931-25-1-0	4931-25-100-0
25F	44F	4932-25-0-0	4932-25-1-0	4932-25-100-0
37M	62M	4931-37-0-0	4931-37-1-0	4931-37-100-0
37F	62F	4932-37-0-0	4932-37-1-0	4932-37-100-0
50M	78M	4931-50-0-0	4931-50-1-0	4931-50-100-0
50F	78F	4932-50-0-0	4932-50-1-0	4932-50-100-0



Positronic
connectpositronic.com



UNIQUE FEATURES

Environmental
D-Sub

U N I Q U E F E A T U R E S

Positronic is **known** around the world **for**
offering our customers **flexibility** when choosing connectors.

In addition to allowing **customers** to **create** part numbers for **particular applications**,
Positronic offers a **wide variety** of features and accessories within our products.

Positronic is also **eager** to modify existing products **to meet unique**
customer requirements. If you do not find what you need
with this catalog, please contact us for assistance.



OTHER SEALED D-SUBMINIATURE CONNECTOR OPTIONS

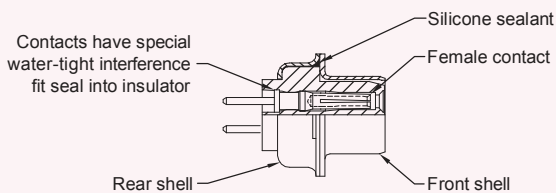

MD STYLE CONNECTOR

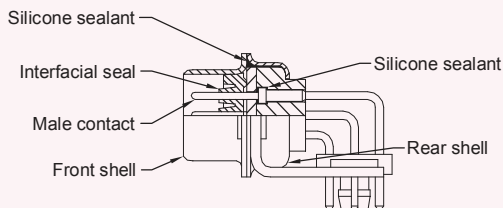

ODD STYLE CONNECTOR

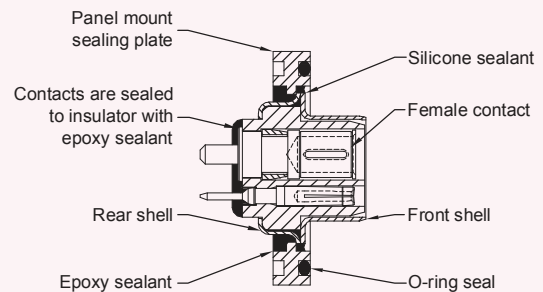

COMBO-D STYLE CONNECTOR

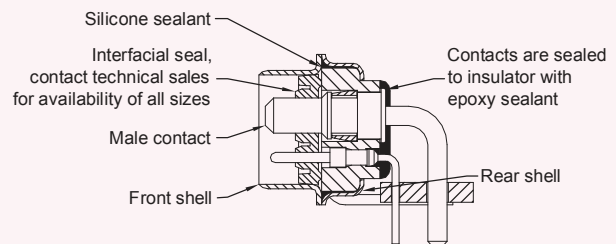

COMBO-D STYLE CONNECTOR

SEALED STANDARD OR HIGH DENSITY D-SUBMINIATURE

- Available in both standard density and high density connector variants.
- Standard MD or ODD series connectors can be sealed between the connector shell and the connector insert.
- Contact technical sales for more information.

SEALED COMBINATION D-SUBMINIATURE

- Could be supplied with mounting plate or without.
- Contact technical sales for more information or additional contact configurations.

UNIQUE FEATURES



MACHINED ALUMINUM MOUNTING PLATE WITH CONDUCTIVE O-RING

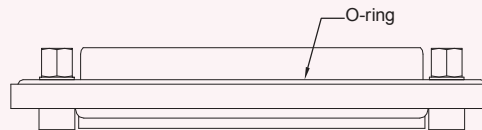
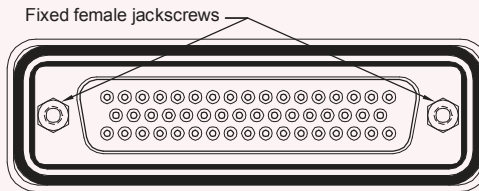
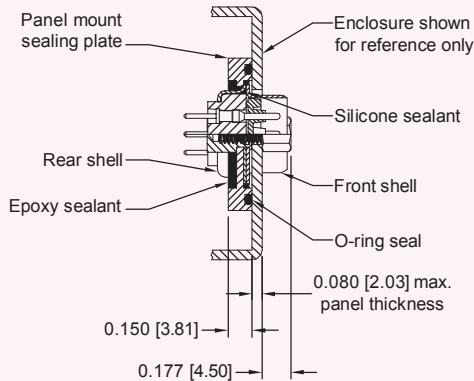

MATERIALS AND FINISHES:

Panel mount sealing plate - Aluminum, yellow chromate coating.

Conductive O-ring - Silver coated thermoplastic elastomer.

CONTACT TECHNICAL SALES FOR MORE INFORMATION

OUTSIDE WALL ENCLOSURE MOUNT

FOR APPLICATIONS REQUIRING SEALED D-SUBMINIATURE CONNECTOR TO BE MOUNTED ON THE OUTSIDE OF THE ENCLOSURE.

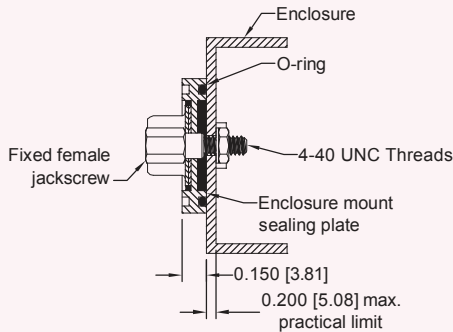

Sealing Plate Material: Glass filled thermoplastic

Note: Sealing plate is mounted to enclosure wall with jackscrews torqued to a value of 1.75 in-lb [0.20 Nm] minimum, 2.25 in-lb [0.25 Nm] maximum.

CONTACT TECHNICAL SALES FOR PART NUMBER

LIGHTWEIGHT ALUMINUM HOOD

Positronic now offers a **Lightweight Aluminum Hood** for use with D-subminiature connectors!

These hoods are offered in the following material and finish combinations:

- Aluminum
- Aluminum with electroless nickel plate
- Aluminum with yellow anodize,
- Aluminum with yellow chromate conversion, zinc content is 1% maximum.

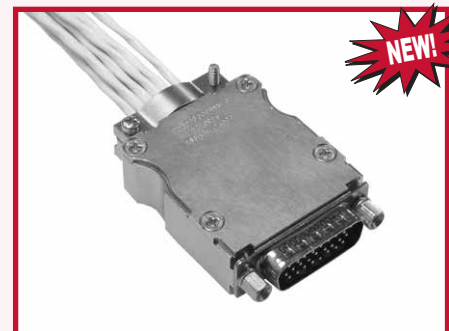



Positronic
connectpositronic.com



UNIQUE FEATURES

Environmental
D-Sub

OTHER ENVIRONMENTAL CONNECTOR OFFERINGS



HERMETIC CONNECTORS

Intended for use as an electrical feed through in high vacuum applications • Leakage rate: $< 5 \times 10^{-9}$ mbar.l/s under a vacuum 1.5×10^{-2} mbar • Signal, power, coax and high voltage versions available • Connectors can be mounted on flange assembly per customer specification

ENVIRONMENTAL CIRCULAR CONNECTORS

Non-corrodible / lightweight composite construction
• EMI/RFI shielded versions • Thermocouple contacts
• Environmentally sealed versions • Rear insertion / front release of removable contacts • Two level sequential mating
• Over molding available on full assemblies



Positronic
connectpositronic.com



APPLICATION TOOLS

Environmental
D-Sub

A P P L I C A T I O N T O O L S S E C T I O N

*EVD connectors are offered with **removable crimp contacts**.*

*Positronic recognizes the **importance of** supplying **application tooling** to support our customers' use of our products.*

Information on application tooling is

***available** on our web site at*

www.connectpositronic.com/tooling

*There you will find **downloadable PDF** cross reference charts for removable and compliant press-in contacts. These charts will **supply part numbers** for insertion, removal and crimping tools, along with **information regarding use** of tools and techniques.*





CONTACT APPLICATION TOOLS CROSS REFERENCE LIST

USE INDICATED POSITRONIC TOOLS FOR BEST RESULTS

Positronic Contact Part Number	Hand Crimp Tool	Mfg. Cross	Mil Equip	Positioner	Mfg. Cross	Mil Equip,	Insertion Tool	Mfg. Cross	Mil Equip.	Removal Tool	Mfg. Cross	Mil. Equip
FC6020D2-14	9507-0-0-0	AFM8	M22520/2-01	9502-5-0-0	K13-1	M22520/2-08	4711-2-0-0	91067-2	M81969/1-02	4711-2-0-0	91067-2	M81969/1-02
FC6020D2AL	9507-0-0-0	AFM8	M22520/2-01	9502-5-0-0	K13-1	M22520/2-08	4711-2-0-0	91067-2	M81969/1-02	4711-2-0-0	91067-2	M81969/1-02
FC6020D2CH	9507-0-0-0	AFM8	M22520/2-01	9502-5-0-0	K13-1	M22520/2-08	4711-2-0-0	91067-2	M81969/1-02	4711-2-0-0	91067-2	M81969/1-02
FC6020D2CO	9507-0-0-0	AFM8	M22520/2-01	9502-5-0-0	K13-1	M22520/2-08	4711-2-0-0	91067-2	M81969/1-02	4711-2-0-0	91067-2	M81969/1-02
FC6020D2CU	9507-0-0-0	AFM8	M22520/2-01	9502-5-0-0	K13-1	M22520/2-08	4711-2-0-0	91067-2	M81969/1-02	4711-2-0-0	91067-2	M81969/1-02
FC6520D2-14	9507-0-0-0	AFM8	M22520/2-01	9502-5-0-0	K13-1	M22520/2-08	4711-2-0-0	91067-2	M81969/1-02	4711-2-0-0	91067-2	M81969/1-02
M39029/63-368	9507-0-0-0	AFM8	M22520/2-01	9502-5-0-0	K13-1	M22520/2-08	4711-2-0-0	91067-2	M81969/1-02	4711-2-0-0	91067-2	M81969/1-02
M39029/64-369	9507-0-0-0	AFM8	M22520/2-01	9502-5-0-0	K13-1	M22520/2-08	4711-2-0-0	91067-2	M81969/1-02	4711-2-0-0	91067-2	M81969/1-02
MC6020D-14	9507-0-0-0	AFM8	M22520/2-01	9502-5-0-0	K13-1	M22520/2-08	4711-2-0-0	91067-2	M81969/1-02	4711-2-0-0	91067-2	M81969/1-02
MC6020DAL	9507-0-0-0	AFM8	M22520/2-01	9502-5-0-0	K13-1	M22520/2-08	4711-2-0-0	91067-2	M81969/1-02	4711-2-0-0	91067-2	M81969/1-02
MC6020DCH	9507-0-0-0	AFM8	M22520/2-01	9502-5-0-0	K13-1	M22520/2-08	4711-2-0-0	91067-2	M81969/1-02	4711-2-0-0	91067-2	M81969/1-02
MC6020DCO	9507-0-0-0	AFM8	M22520/2-01	9502-5-0-0	K13-1	M22520/2-08	4711-2-0-0	91067-2	M81969/1-02	4711-2-0-0	91067-2	M81969/1-02
MC6020DCU	9507-0-0-0	AFM8	M22520/2-01	9502-5-0-0	K13-1	M22520/2-08	4711-2-0-0	91067-2	M81969/1-02	4711-2-0-0	91067-2	M81969/1-02







EXPLANATION OF INGRESS PROTECTION (IP) SYSTEM FOR ENCLOSURES

This system outlined in IEC 60529 is designed to indicate the standard degrees of protection: from (a) touch and ingress of solids, and (b) from ingress of liquids, which enclosures may exhibit, and must not be confused with explosion protection techniques. These degrees of protection are, however, frequently referred to in standards and literature, and hence are listed below.

The first numeral designates the degree of protection against touching live parts and ingress of solid foreign bodies, the second designates the degree of protection against ingress of liquid.

The higher the numeral of the first and second characteristic, the greater degree of protection the enclosure offers, e.g. IP55 meets all the less onerous degrees such as IP22, IP23, IP34 and IP54. The term “weatherproof” is not included at present in the IP system but IP54 enclosures are frequently described in this way.

PROTECTION OF EQUIPMENT AGAINST INGRESS OF SOLID BODIES AND LIQUIDS

SOLID FOREIGN BODIES			LIQUIDS	
FIRST CHARACTERISTIC NUMERAL	OBJECT SIZE	DEGREE OF PROTECTION	SECOND CHARACTERISTIC NUMERAL	DEGREE OF PROTECTION
0		No protection of persons against contact with live or moving parts inside the enclosure. No protection of equipment against ingress of solid foreign bodies.	0	No protection.
1	>50 mm 	Protection against accidental or inadvertent contact with live or moving parts inside the enclosure by a large surface of the human body, e.g. a hand, but not protection against deliberate access to such parts. Protection against ingress of large solid foreign bodies.	1	Protection against drops of condensed water. Drops of condensed water falling on the enclosure shall have no harmful effect.
2	>12.5 mm 	Protection against contact with live or moving parts inside the enclosure by fingers. Protection against ingress of medium size solid foreign bodies.	2	Protection against drops of liquid. Drops of falling liquid shall have no harmful effect when the enclosure is tilted at any angle up to 15° from the vertical.
3	>2.5 mm 	Protection against contact with live or moving parts inside the enclosure by tools, wires or such objects of thickness greater than 2.5 mm. Protection against ingress of small solid foreign bodies.	3	Protection against rain. Water falling in rain at an angle equal to or smaller than 60° with respect to the vertical shall have no harmful effect.
4	>1.0 mm 	Protection against contact with live or moving parts, inside the enclosure by tools, wires or such objects of thickness greater than 1 mm. Protection against ingress of small solid foreign bodies.	4	Protection against splashing. Liquid splashed from any direction shall have no harmful effect.
5		Complete protection against contact with live or moving parts inside the enclosure. Protection against harmful deposits of dust. The ingress of dust is not totally prevented, but dust cannot enter in an amount sufficient to interfere with satisfactory operation of the equipment enclosed.	5	Protection against water jets. Water projected by a nozzle from any direction under stated conditions shall have no harmful effect.
6		Complete protection against contact with live or moving parts inside the enclosure. Protection against ingress of dust.	6	Protection against conditions on ships' decks (deck watertight equipment). Water from heavy seas shall not enter the enclosures under prescribed conditions.
			7	Protection against immersion in water. It shall not be possible for water to enter the enclosure under stated conditions of pressure and time.
			8	Protection against indefinite immersion in water under specified pressure. It shall not be possible for water to enter the enclosure.



DESCRIPTION OF NEMA ENCLOSURE TYPES

TYPE	INTENDED USE AND DESCRIPTION
1	Indoor use primarily to provide a degree of protection against limited amounts of falling dirt.
2	Indoor use primarily to provide a degree of protection against limited amounts of falling water and dirt.
3	Outdoor use primarily to provide a degree of protection against rain, sleet, windblown dust and damage from external ice formation.
3R	Outdoor use primarily to provide a degree of protection against rain, sleet and damage from external ice formation.
3S	Outdoor use primarily to provide a degree of protection against rain, sleet, windblown dust and to provide for operation of external mechanisms when ice laden.
4	Indoor or outdoor use primarily to provide a degree of protection against windblown dust and rain, splashing water, hose-directed water and damage from external ice formation.
4X	Indoor or outdoor use primarily to provide a degree of protection against corrosion, windblown dust and rain, splashing water, hose-directed water and damage from external ice formation.
5	Indoor use primarily to provide a degree of protection against settling airborne dust, falling dirt and dripping noncorrosive liquids.
6	Indoor or outdoor use primarily to provide a degree of protection against hose-directed water and the entry of water during occasional temporary submersion at a limited depth and damage from external ice formation.
6P	Indoor or outdoor use primarily to provide a degree of protection against hose-directed water, the entry of water during prolonged submersion at a limited depth and damage from external ice formation.
12, 12K	Indoor use primarily to provide a degree of protection against circulating dust, falling dust, falling dirt and dripping noncorrosive liquids.
13	Indoor use primarily to provide a degree of protection against dust, spraying of water, oil and noncorrosive coolant.

This material is reproduced from NEMA Standards Publication 250-1991 by permission of the National Electrical Manufacturers Association which holds the copyright.



COMPARISON BETWEEN NEMA ENCLOSURE TYPE NUMBERS AND IEC ENCLOSURE CLASSIFICATION DESIGNATIONS

IEC Publication 60529, Classification of Degrees of Protection Provided by Enclosures, provides a system for specifying the enclosures of electrical equipment on the basis of the degree of protection provided by the enclosure. IEC 60529 does not specify degrees of protection against mechanical damage of equipment, risk of explosions or conditions such as moisture (produced for example by condensation), corrosive vapors, fungus or vermin. NEMA Standards Publication 250 does test for environmental conditions such as corrosion, rust, icing, oil and coolants. For this reason, and because the tests and evaluations for other characteristics are not identical, the IEC Enclosure Classification Designations cannot be exactly equated with NEMA Enclosure Type Numbers.

The IEC designation consists of the letters IP followed by two numerals. The first characteristic numeral indicates the degree of protection provided by the first enclosure with respect to persons and solid foreign objects entering the enclosure. The second characteristic numeral indicates the degree of protection provided by the enclosure with respect to the harmful ingress of water.

The Table provides an approximate equivalent conversion from NEMA Enclosure Type Numbers to IEC Enclosure Classification Designations. The NEMA Types meet or exceed the test requirements for the associated IEC Classifications; for this reason the Table cannot be used to convert exactly from IEC Classifications to NEMA Types.

COMPARISON OF NEMA TYPE NUMBERS TO IEC CLASSIFICATION DESIGNATIONS

(Cannot be used to convert IEC Classification Designations to NEMA Type Numbers)

NEMA ENCLOSURE TYPE NUMBER	IEC ENCLOSURE CLASSIFICATION DESIGNATION
1	IP10
2	IP11
3	IP54
3r	IP14
3s	IP54
4 and 4x	IP56
5	IP52
6 and 6p	IP67
12 and 12K	IP52
13	IP54

This material is reproduced from NEMA Standards Publication 250-1991 by permission of the National Electrical Manufacturers Association which holds the copyright.

Note: This comparison is based on tests specified in IEC Publication 60529.

OTHER D-SUBMINIATURE PRODUCTS

Positronic offers a full line of D-subminiature connectors in a wide variety of contact variants and package sizes with press-fit, solder and cable terminations. All Positronic connector products provide quality, reliability and flexibility.

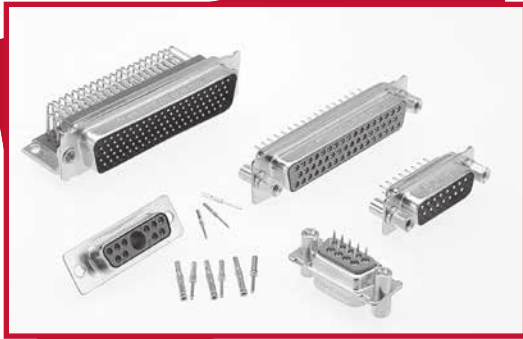

HIGH PERFORMANCE D-SUBMINIATURE CONNECTORS

Standard and high density connectors manufactured to MIL-PRF-24308, Class M; Goddard Space Flight Center S-311-P-4 and Goddard Space Flight Center S-311-P-10.

COMPLIANT PRESS-IN CONNECTORS

Standard and high density connectors
Straight and right angle (90°) printed board mount
Low press-in force eliminates stress on printed circuit board during insertion.



COMBO-D CONNECTORS

Connectors with signal, shielded, power, thermocouple or high voltage contacts in a single package.
Power press-fit terminations now available.

DUAL PORT CONNECTORS

Right angle (90°) printed board mount connectors assembled stacked to maximize real estate; contact variants 9 through 62; available in standard density, high density, and mixed density.

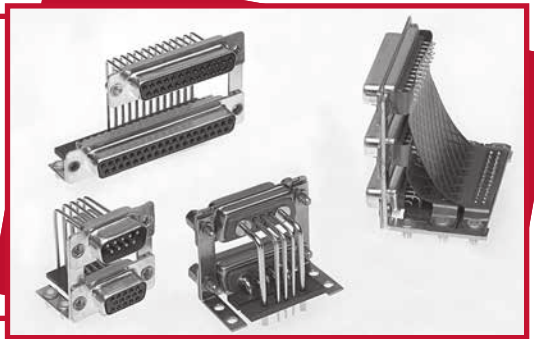

Connector Excellence[®]

Positronic HIGH RELIABILITY Products

POWER



FEATURES:

- High current density
- Energy saving - low contact resistance
- AC/DC operation in a single connector
- Signal contacts for hardware management
- Blind mating
- Sequential mating
- Large surface area contact mating system
- Wide variety of accessories
- Customer-specified contact arrangements
- Modular tooling which produces a single piece connector insert

Contact Sizes: 0, 8, 12, 16, 20, 22 and 24
Current Ratings: To 200 amperes per contact
Terminations: Crimp and fixed cable connector, straight solder, right angle (90°) solder, straight compliant press-in and right angle (90°) compliant press-in
Configurations: Multiple variants in a variety of package sizes
Compliance: PICMG 2.11, PICMG 3.0, VITA 41, DSCC, GSFC S-311-P-4, GSFC S-311-P-10

D - SUB MINIATURE



FEATURES:

- Four performance levels available for best cost/performance ratio: professional, industrial, military and space-flight quality
- Options include high voltage, coax, thermocouple and air coupling contacts; environmentally sealed and dual port connector packages including mixed density
- Broad selection of accessories
- Size 20 and 22 contacts suitable for use in carrying power
- IP65, IP67

Contact Sizes: 8, 16, 20 and 22
Current Ratings: To 100 amperes
Terminations: Crimp, wire solder, straight solder, right angle (90°) compliant press-in and right angle (90°) compliant press-in
Configurations: Multiple variants in both standard and high densities, seven connector housing sizes
Qualifications: MIL-DTL-24308, GSFC S-311-P-4, GSFC S-311-P-10, SAE AS39029, DSCC

RECTANGULAR



FEATURES:

- Two performance levels available: industrial quality and military quality
- A wide variety of accessories
- Broad selection of contact arrangement and package sizes
- Connector coding device (keying) options

Contact Sizes: 16, 20 and 22
Current Ratings: To 13 amperes nominal
Terminations: Crimp, wire solder, straight solder, right angle (90°) solder, and straight compliant press-in
Configurations: Multiple variants in both standard and high densities, thirty package sizes
Qualifications: MIL-DTL-28748, SAE AS39029, CCITT V,35

CIRCULAR



FEATURES:

- Non-corrodible / lightweight composite construction
- EMI/RFI shielded versions
- Thermocouple contacts
- Environmentally sealed versions
- Rear insertion/ front release of removable contacts
- Two level sequential mating
- Overmolding available on full assemblies

Contact Sizes: 12, 16, 20 and 22
Current Ratings: To 25 amperes nominal
Terminations: Crimp, wire solder, straight solder, and right angle (90°) solder
Configurations: Multiple variants in four package sizes
Qualifications: Environmental protection to IP67

CABLE



FEATURES:

- Shorten the supply chain and reduce additional costs and delays by "cabling" your Positronic connector selection
- Overmolding available
- Shielded and environmentally sealed versions available
- Power cables and access boxes which meet the SAE J2496 specification

- ✓ Design assemblies in accordance with customer specifications.
- ✓ Prepare wire harness connector configuration and performance specifications.
- ✓ Design each system in accordance with applicable customer, domestic, and international standards.
- ✓ Define and conduct performance and verification testing.

HERMETIC



FEATURES:

- Intended for use as an electrical feedthrough in high vacuum applications
- Helium leakage rate at ambient temperature: $< 5 \times 10^{-9}$ mbar.l/s under a vacuum 1.5×10^{-2} mbar
- Signal, power, coax and high voltage versions available
- Connectors can be mounted on flange assembly per customer specification

Contact Sizes: 8, 12, 16, 20 and 22
Current Ratings: To 40 amperes nominal
Terminations: Feedthrough is standard; flying leads and board mount available upon request
Configurations: See D-subminiature and circular configurations above
Compliance: Space-D32

For more information, visit www.connectpositronic.com or call your nearest Positronic sales office listed on the back of this catalog.



Positronic[®]
an Amphenol company

Regional Headquarters

Positronic | USA
1325 N Eldon Ave
Springfield MO 65803 USA

+1 800 641 4054
info@connectpositronic.com

Positronic | Europe
Z.I. d'Engachies
46, route d'Engachies
F-32020 Auch Cedex 9 France

+33 5 6263 4491
contact@connectpositronic.com

Positronic | Asia
3014A Ubi Rd 1 #07-01
Singapore 408703

+65 6842 1419
singapore@connectpositronic.com

Sales Offices

Positronic has local sales representation all over the world. To find the nearest sales office, please visit www.connectpositronic.com/locations

LOCATIONS

www.connectpositronic.com