



soberton inc.

# PB PIEZO AUDIO BUZZER

Acoustic Product Specification

Product Number: PB-4333N-1



Release | Revision: B/2018

## CONTENTS

This document contains the technical specifications for the piezo audio buzzer.

### Page 1

Specifications

Mechanical Characteristics

### Page 2

Environment Test

Reliability Test

### Page 3

Measuring Method

### Page 4

Dimensions

### Page 5

Packing

## Specifications

Item	Unit	Specification	Condition
Rated Voltage	VDC	24.0	
Operating Volt	VDC	12.0 ~ 36.0	
Mean Current	mA	20 Max.	At rated voltage
Sound Output	dBa	90 Min.	At 30cm at rated voltage
Resonant Frequency	Hz	2900 ±500	
Operating Temp	°C	-20 ~ +60	
Storage Temp	°C	-30 ~ +70	
Dimension	mm	Ø 43.0 × H33.0	
Housing Material	gram	40	
Material		ABS (black)	
Terminal		Screw type Plating (Ni)	See Dimensions
Environmental Protection Regulation		RoHS	

### Test condition:

Temperature: +25±2 °C    Related humidity: 65±5%    Air pressure: 86-106KPa

## Mechanical Characteristics

Item	Test condition	Evaluation standard
Terminal Mechanical Strength	The force of 9.8N(1.0kg) is applied to each terminal in axial direction for 10 seconds. No visible damage and cutting off.	No damage and cutting off
Vibration	The buzzer shall be measured after a vibration of amplitude of 1.5mm with 10Hz to 55Hz band of vibration frequency is applied to each of 3 perpendicular directions for 2 hours.	The value of oscillation frequency/ current consumption should be in ±10% compared with initial ones.
Drop Test	The part is dropped from a height of 70cm onto a 40mm thick wooden board 3 times in 3 axes(X,Y,Z). A total of 9 times.	The SPL should be in ±10dB compared with initial one.



soberton inc.

# PB PIEZO AUDIO BUZZER

Acoustic Product Specification

Product Number: PB-4333N-1



Release | Revision: B/2018

## CONTENTS

This document contains the technical specifications for the piezo audio buzzer.

### Page 1

Specifications

Mechanical Characteristics

### Page 2

Environment Test

Reliability Test

### Page 3

Measuring Method

### Page 4

Dimensions

### Page 5

Packing

## Environment Test

Item	Test condition	Evaluation standard
High temp. test	The part is placed in a chamber at +70°C for 96 hours	Being placed for 4 hours at +25°C, buzzer shall be measured.
Low temp. test	The part is placed in a chamber at -30°C for 96 hours	The value of oscillation, frequency / current consumption should be in ±10% compared with initial ones.
Humidity test	The part is placed in a chamber at +40°C and 90±5% relative humidity for 96 hours	The SPL should be in ±10dB compared with initial one.
Temp cycle test	The part shall be subjected to 5 cycles. Each cycle shall consist of:	

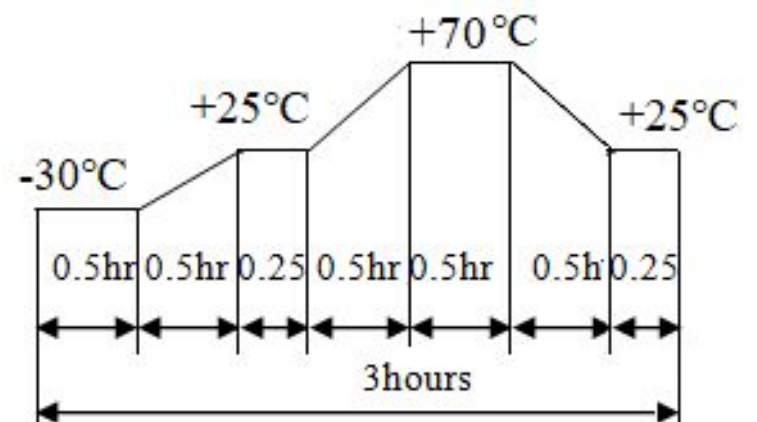

## Reliability Test

Item	Test condition	Evaluation standard
Operating Life Test	<p><b>1. Continuous life test</b> 72 hours of continuous operation at +70°C with the maximum rated voltage applied.</p> <p><b>2. Intermittent life test</b> A duty cycle of 1 minute on, 1 minutes off, a minimum of 1000 times at +25±2°C and the maximum rated voltage applied.</p>	<p>After the test, the part shall meet specifications without any degradation in appearance and performance except SPL.</p> <p>After 4 hours at +25°C, the SPL should be in ±10dBA compared with initial one.</p>

### Standard test condition:

- a) Temperature: +5~+35°C
- b) Humidity: 45~85%
- c) Pressure: 86~106KPa



soberton inc.

# PB PIEZO AUDIO BUZZER

Acoustic Product Specification

Product Number: PB-4333N-1



Release | Revision: B/2018

## CONTENTS

This document contains the technical specifications for the piezo audio buzzer.

### Page 1

Specifications

Mechanical Characteristics

### Page 2

Environment Test

Reliability Test

### Page 3

Measuring Method

### Page 4

Dimensions

### Page 5

Packing

## Measuring Method

### S.P.L Measuring Circuit

Input Signal: 24.0 VDC

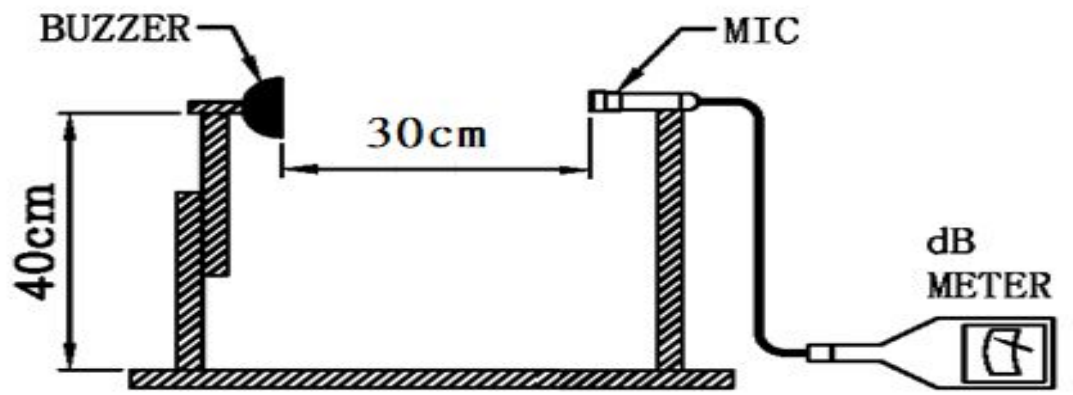

MIC: S.P.L meter TES1351B or equivalent



soberton inc.

# PB PIEZO AUDIO BUZZER

Acoustic Product Specification

Product Number: PB-4333N-1



Release | Revision: B/2018

## CONTENTS

This document contains the technical specifications for the piezo audio buzzer.

### Page 1

Specifications

Mechanical Characteristics

### Page 2

Environment Test

Reliability Test

### Page 3

Measuring Method

### Page 4

Dimensions

### Page 5

Packing

## Dimensions

Tolerance:  $\pm 0.5$  (unit: mm)

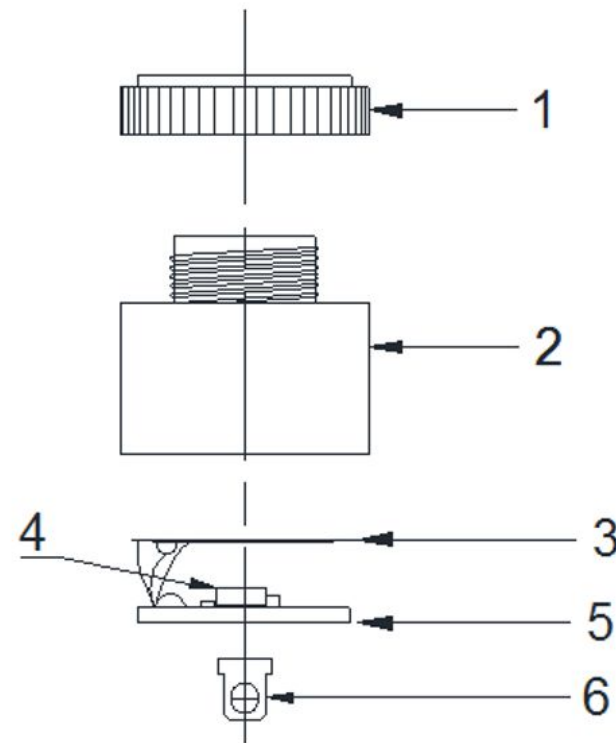
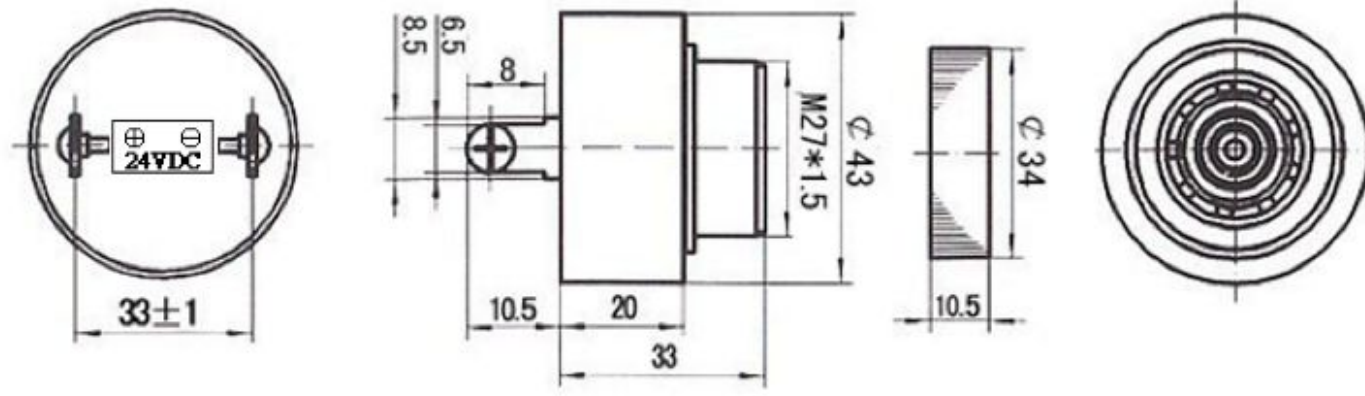

No.	Part Name	Material	Quantity
1	Case	ABS	1
2	Case	ABS	1
3	Piezo	Copper + Ceramics	1
4	Transistor	Epoxy + Copper	1
5	Cover/PCB	Epoxy	1
6	Screw	Fe	2



soberton inc.

# PB PIEZO AUDIO BUZZER

Acoustic Product Specification

Product Number: PB-4333N-1



Release | Revision: B/2018

## CONTENTS

This document contains the technical specifications for the piezo audio buzzer.

### Page 1

Specifications

Mechanical Characteristics

### Page 2

Environment Test

Reliability Test

### Page 3

Measuring Method

### Page 4

Dimensions

### Page 5

Packing

## Packing

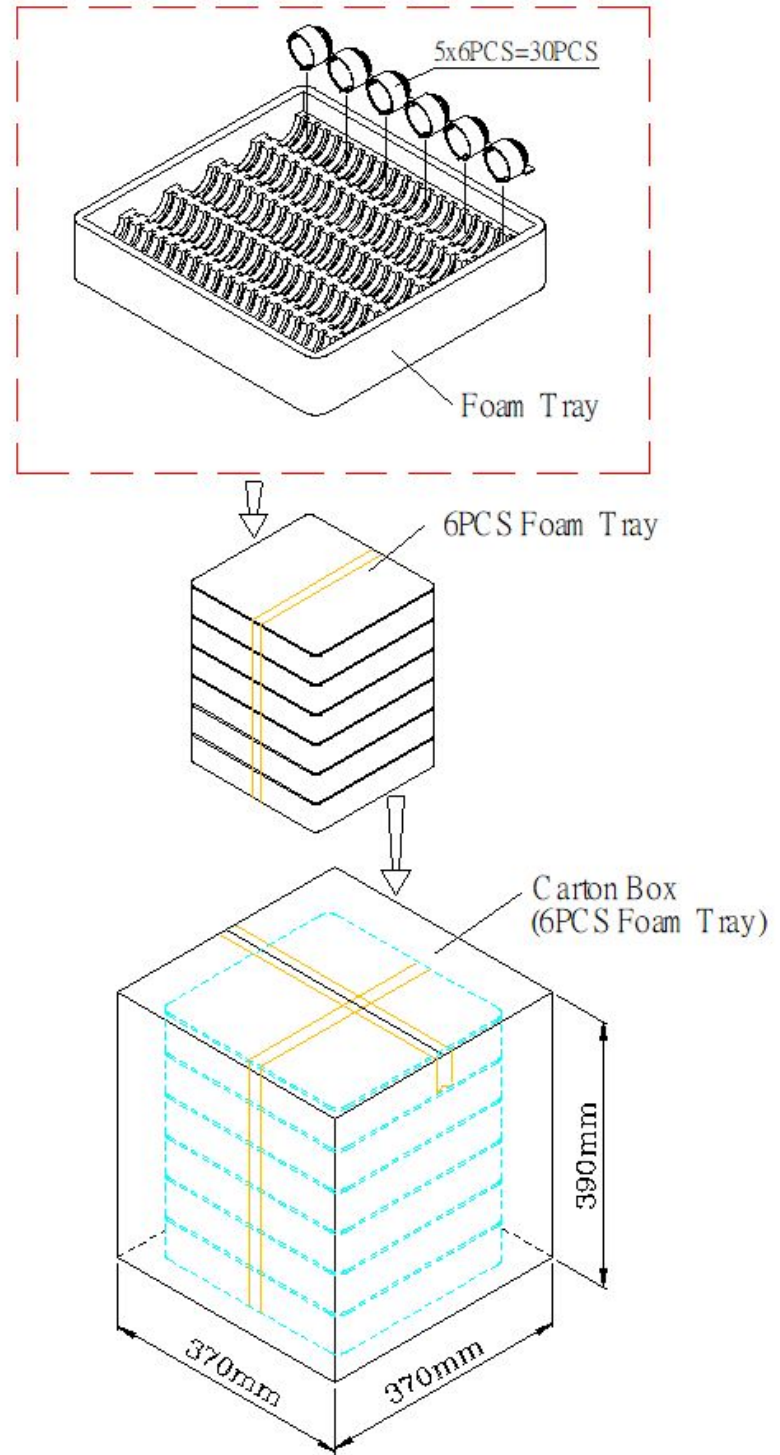

## Details

Foam Tray	300 x 280 x 60mm	1 x 30PCS = 30PCS
Carton Box	370 x 370 x 390mm	6 x 30PCS = 180PCS