

Features

- True dual-ported memory cells, which allow simultaneous reads of the same memory location
- 1K x 8 organization
- 0.65 micron CMOS for optimum speed and power
- High speed access: 15 ns
- Low operating power: $I_{CC} = 110$ mA (maximum)
- Fully asynchronous operation
- Automatic power down
- Master CY7C130/130A/CY7C131/131A easily expands data bus width to 16 or more bits using slave CY7C140/CY7C141
- \overline{BUSY} output flag on CY7C130/130A/CY7C131/131A; \overline{BUSY} input on CY7C140/CY7C141
- \overline{INT} flag for port-to-port communication
- Available in 48-pin DIP (CY7C130/130A/140), 52-pin PLCC, 52-pin TQFP
- Pb-free packages available

Functional Description

The CY7C130/130A/CY7C131/131A/CY7C140^[1] and CY7C141 are high speed CMOS 1K by 8 dual-port static RAMs. Two ports are provided permitting independent access to any location in memory. The CY7C130/130A/ CY7C131/131A can be used as either a standalone 8-bit dual-port static RAM or as a master dual-port RAM in conjunction with the CY7C140/CY7C141 slave dual-port device in systems requiring 16-bit or greater word widths. It is the solution to applications requiring shared or buffered data, such as cache memory for DSP, bit-slice, or multi-processor designs.

Each port has independent control pins; chip enable (\overline{CE}), write enable (R/W), and output enable (\overline{OE}). Two flags are provided on each port, \overline{BUSY} and \overline{INT} . \overline{BUSY} signals that the port is trying to access the same location currently being accessed by the other port. \overline{INT} is an interrupt flag indicating that data is placed in a unique location (3FF for the left port and 3FE for the right port). An automatic power down feature is controlled independently on each port by the chip enable (\overline{CE}) pins.

The CY7C130/130A and CY7C140 are available in 48-pin DIP. The CY7C131/131A and CY7C141 are available in 52-pin PLCC, 52-pin Pb-free PLCC, 52-pin PQFP, and 52-pin Pb-free PQFP.

Logic Block Diagram

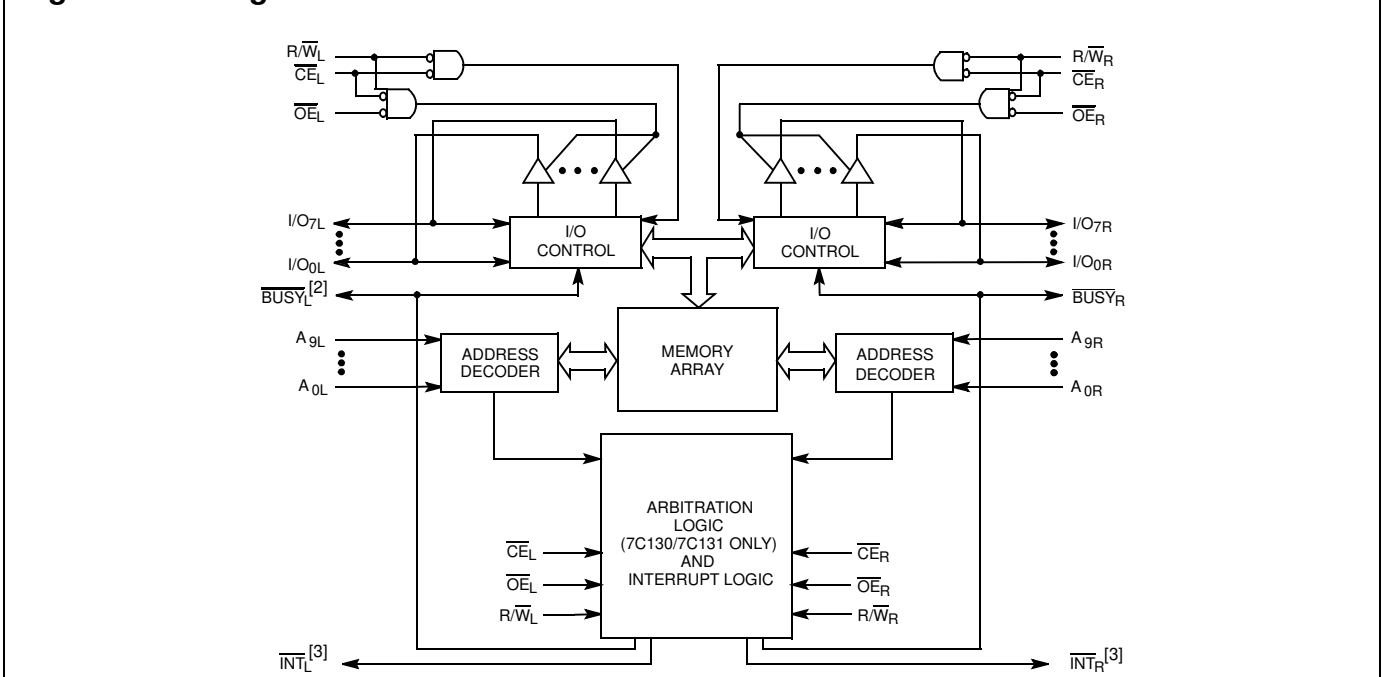

Notes

1. CY7C130 and CY7C130A are functionally identical; CY7C131 and CY7C131A are functionally identical.
2. CY7C130/130A/CY7C131/131A (Master): \overline{BUSY} is open drain output and requires pull-up resistor.
CY7C140/CY7C141 (Slave): \overline{BUSY} is input.
3. Open drain outputs: pull-up resistor required.

Pin Configurations

Figure 1. Pin Diagram - DIP (Top View)

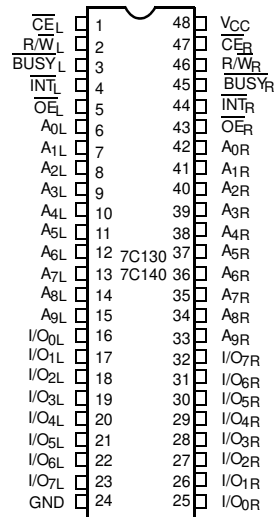

Figure 2. Pin Diagram - PLCC (Top View)

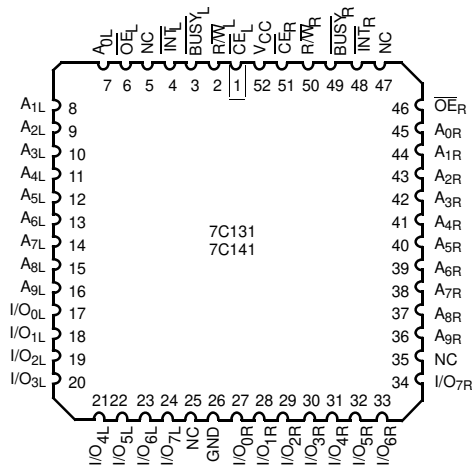
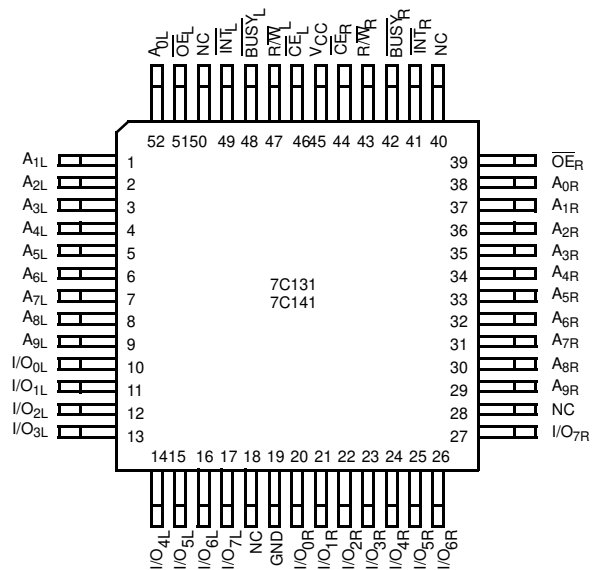

Figure 3. Pin Diagram - PQFP (Top View)



Pin Definitions

Left Port	Right Port	Description
\overline{CE}_L	\overline{CE}_R	Chip Enable
R/W_L	R/W_R	Read/Write Enable
\overline{OE}_L	\overline{OE}_R	Output Enable
$A_{0L}-A_{11/12L}$	$A_{0R}-A_{11/12R}$	Address
$I/O_{0L}-I/O_{15/17L}$	$I/O_{0R}-I/O_{15/17R}$	Data Bus Input/Output
\overline{INT}_L	\overline{INT}_R	Interrupt Flag
\overline{BUSY}_L	\overline{BUSY}_R	Busy Flag
V_{CC}		Power
GND		Ground

Selection Guide

Parameter		7C131-15 ^[4] 7C131A-15 7C141-15	7C131-25 ^[4] 7C141-25	7C130-30 7C130A-30 7C131-30 7C140-30 7C141-30	7C130-35 7C131-35 7C140-35 7C141-35	7C130-45 7C131-45 7C140-45 7C141-45	7C130-55 7C131-55 7C140-55 7C141-55	Unit
Maximum Access Time		15	25	30	35	45	55	ns
Maximum Operating Current	Com/I/Ind	190	170	170	120	120	110	mA
Maximum Standby Current	Com/I/Ind	75	65	65	45	45	35	mA

Shaded areas contain preliminary information.

Note

4. 15 and 25 ns version available only in PLCC/PQFP packages.

Maximum Ratings^[5]

Exceeding maximum ratings may shorten the useful life of the device. User guidelines are not tested.

Storage Temperature	-65°C to +150°C
Ambient Temperature with Power Applied	-55°C to +125°C
Supply Voltage to Ground Potential (Pin 48 to Pin 24)	-0.5V to +7.0V
DC Voltage Applied to Outputs in High Z State	-0.5V to +7.0V

DC Input Voltage	-3.5V to +7.0V
Output Current into Outputs (LOW)	20 mA
Static Discharge Voltage	>2001V (per MIL-STD-883, Method 3015)
Latch Up Current	>200 mA

Operating Range

Range	Ambient Temperature	V _{CC}
Commercial	0°C to +70°C	5V ± 10%
Industrial	-40°C to +85°C	5V ± 10%
Military ^[6]	-55°C to +125°C	5V ± 10%

Electrical Characteristics Over the Operating Range^[7]

Parameter	Description	Test Conditions	7C131-15 ^[4] 7C131A-15 7C141-15		7C130-30 ^[4] 7C130A-30 7C131-25,30 7C140-30 7C141-25,30		7C130-35,45 7C131-35,45 7C140-35,45 7C141-35,45		7C130-55 7C131-55 7C140-55 7C141-55		Unit
			Min	Max	Min	Max	Min	Max	Min	Max	
V _{OH}	Output HIGH Voltage	V _{CC} = Min, I _{OH} = -4.0 mA	2.4		2.4		2.4		2.4		V
V _{OL}	Output LOW Voltage	I _{OL} = 4.0 mA		0.4		0.4		0.4		0.4	V
		I _{OL} = 16.0 mA ^[8]		0.5		0.5		0.5		0.5	V
V _{IH}	Input HIGH Voltage		2.2		2.2		2.2		2.2		V
V _{IL}	Input LOW Voltage			0.8		0.8		0.8		0.8	V
I _{IX}	Input Leakage Current	GND ≤ V _I ≤ V _{CC}	-5	+5	-5	+5	-5	+5	-5	+5	μA
I _{OZ}	Output Leakage Current	GND ≤ V _O ≤ V _{CC} , Output Disabled	-5	+5	-5	+5	-5	+5	-5	+5	μA
I _{OS}	Output Short Circuit Current ^[9, 10]	V _{CC} = Max, V _{OUT} = GND		-350		-350		-350		-350	mA
I _{CC}	V _{CC} Operating Supply Current	CE = V _{IL} , Outputs Open, f = f _{MAX} ^[11]	Com'l	190		170		120		110	mA
I _{SB1}	Standby Current Both Ports, TTL Inputs	CE _L and CE _R ≥ V _{IH} , f = f _{MAX} ^[11]	Com'l	75		65		45		35	mA
I _{SB2}	Standby Current One Port, TTL Inputs	CE _L or CE _R ≥ V _{IH} , Active Port Outputs Open f = f _{MAX} ^[11]	Com'l	135		115		90		75	mA
I _{SB3}	Standby Current Both Ports, CMOS Inputs	Both Ports CE _L and CE _R ≥ V _{CC} - 0.2V, V _{IN} ≥ V _{CC} - 0.2V or V _{IN} ≤ 0.2V, f = 0	Com'l	15		15		15		15	mA
I _{SB4}	Standby Current One Port, CMOS Inputs	One Port CE _L or CE _R ≥ V _{CC} - 0.2V, V _{IN} ≥ V _{CC} - 0.2V or V _{IN} ≤ 0.2V, Active Port Outputs Open, f = f _{MAX} ^[11]	Com'l	125		105		85		70	mA

Shaded areas contain preliminary information.

Notes

- The voltage on any input or I/O pin cannot exceed the power pin during power up.
- T_A is the "instant on" case temperature
- See the last page of this specification for Group A subgroup testing information.
- BUSY and INT pins only.
- Duration of the short circuit should not exceed 30 seconds.
- This parameter is guaranteed but not tested.
- At f = f_{MAX}, address and data inputs are cycling at the maximum frequency of read cycle of 1/t_{RC} and using AC Test Waveforms input levels of GND to 3V.

Capacitance^[10]

Parameter	Description	Test Conditions	Max	Unit
C_{IN}	Input Capacitance	$T_A = 25^\circ\text{C}$, $f = 1\text{ MHz}$, $V_{CC} = 5.0\text{V}$	15	pF
C_{OUT}	Output Capacitance		10	pF

Figure 4. AC Test Loads and Waveforms

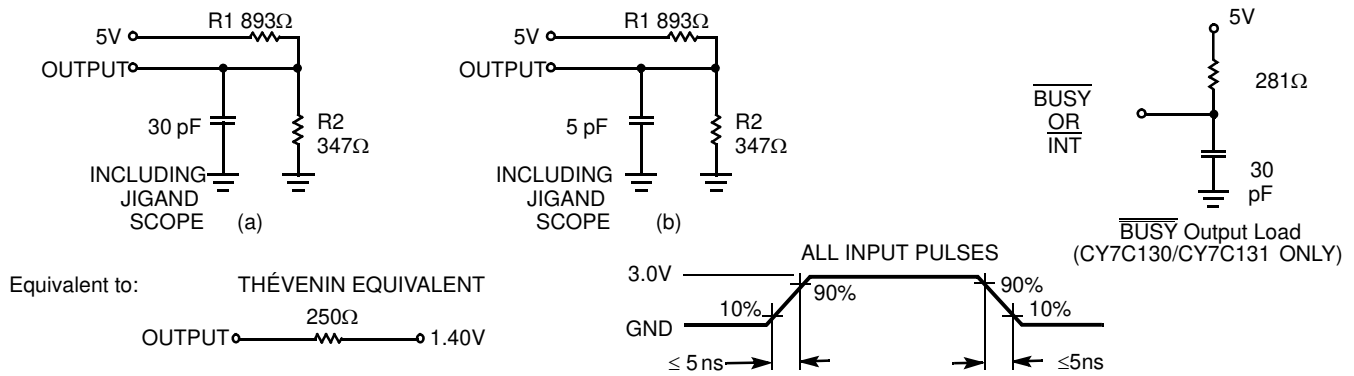

Switching Characteristics Over the Operating Range^[7, 12]

Parameter	Description	7C131-15 ^[4] 7C131A-15 7C141-15		7C130-25 ^[4] 7C131-25 7C140-25 7C141-25		7C130-30 7C130A-30 7C131-30 7C140-30 7C141-30		Unit
		Min	Max	Min	Max	Min	Max	
Read Cycle								
t _{RC}	Read Cycle Time	15		25		30		ns
t _{AA}	Address to Data Valid ^[13]		15		25		30	ns
t _{OHA}	Data Hold from Address Change	0		0		0		ns
t _{ACE}	CE LOW to Data Valid ^[13]		15		25		30	ns
t _{DOE}	OE LOW to Data Valid ^[13]		10		15		20	ns
t _{LZOE}	OE LOW to Low Z ^[10, 14, 15]	3		3		3		ns
t _{HZOE}	OE HIGH to High Z ^[10, 14, 15]		10		15		15	ns
t _{LZCE}	CE LOW to Low Z ^[10, 14, 15]	3		5		5		ns
t _{HZCE}	CE HIGH to High Z ^[10, 14, 15]		10		15		15	ns
t _{PU}	CE LOW to Power Up ^[10]	0		0		0		ns
t _{PD}	CE HIGH to Power Down ^[10]		15		25		25	ns
Write Cycle^[16]								
t _{WC}	Write Cycle Time	15		25		30		ns
t _{SCE}	CE LOW to Write End	12		20		25		ns
t _{AW}	Address Setup to Write End	12		20		25		ns
t _{HA}	Address Hold from Write End	2		2		2		ns
t _{SA}	Address Setup to Write Start	0		0		0		ns
t _{PWE}	R/W Pulse Width	12		15		25		ns
t _{SD}	Data Setup to Write End	10		15		15		ns
t _{HD}	Data Hold from Write End	0		0		0		ns
t _{HZWE}	R/W LOW to High Z ^[15]		10		15		15	ns
t _{LZWE}	R/W HIGH to Low Z ^[15]	0		0		0		ns

Shaded areas contain preliminary information.

Notes

12. Test conditions assume signal transition times of 5 ns or less, timing reference levels of 1.5V, input pulse levels of 0 to 3.0V and output loading of the specified I_{OL}/I_{OH} and 30 pF load capacitance.
13. AC Test Conditions use V_{OH} = 1.6V and V_{OL} = 1.4V.
14. At any given temperature and voltage condition for any given device, t_{HZCE} is less than t_{LZCE} and t_{HZOE} is less than t_{LZOE}.
15. t_{LZCE}, t_{LZWE}, t_{HZOE}, t_{LZOE}, t_{HZCE} and t_{HZWE} are tested with C_L = 5 pF as in part (b) of AC Test Loads. Transition is measured ±500 mV from steady state voltage.
16. The internal write time of the memory is defined by the overlap of CS LOW and R/W LOW. Both signals must be low to initiate a write and either signal can terminate a write by going high. The data input setup and hold timing should be referenced to the rising edge of the signal that terminates the write.

Switching Characteristics Over the Operating Range^[7, 12] (continued)

Parameter	Description	7C131-15 ^[4] 7C131A-15 7C141-15		7C130-25 ^[4] 7C131-25 7C140-25 7C141-25		7C130-30 7C130A-30 7C131-30 7C140-30 7C141-30		Unit
		Min	Max	Min	Max	Min	Max	
Busy/Interrupt Timing								
t _{BLA}	BUSY LOW from Address Match		15		20		20	ns
t _{BHA}	BUSY HIGH from Address Mismatch ^[17]		15		20		20	ns
t _{BLC}	BUSY LOW from CE LOW		15		20		20	ns
t _{BHC}	BUSY HIGH from CE HIGH ^[17]		15		20		20	ns
t _{PS}	Port Set Up for Priority	5		5		5		ns
t _{WB} ^[18]	R/W LOW after BUSY LOW	0		0		0		ns
t _{WH}	R/W HIGH after BUSY HIGH	13		20		30		ns
t _{BDD}	BUSY HIGH to Valid Data		15		25		30	ns
t _{DDD}	Write Data Valid to Read Data Valid		Note 19		Note 19		Note 19	ns
t _{WDD}	Write Pulse to Data Delay		Note 19		Note 19		Note 19	ns
Interrupt Timing								
t _{WINS}	R/W to INTERRUPT Set Time		15		25		25	ns
t _{EINS}	CE to INTERRUPT Set Time		15		25		25	ns
t _{INS}	Address to INTERRUPT Set Time		15		25		25	ns
t _{OINR}	OE to INTERRUPT Reset Time ^[17]		15		25		25	ns
t _{EINR}	CE to INTERRUPT Reset Time ^[17]		15		25		25	ns
t _{INR}	Address to INTERRUPT Reset Time ^[17]		15		25		25	ns

Shaded areas contain preliminary information.

Notes

- 17. These parameters are measured from the input signal changing, until the output pin goes to a high-impedance state.
- 18. CY7C140/CY7C141 only.
- 19. A write operation on Port A, where Port A has priority, leaves the data on Port B's outputs undisturbed until one access time after one of the following:
 BUSY on Port B goes HIGH.
 Port B's address is toggled.
 CE for Port B is toggled.
 R/W for Port B is toggled during valid read.

Switching Characteristics Over the Operating Range^[7,12]

Parameter	Description	7C130-35 7C131-35 7C140-35 7C141-35		7C130-45 7C131-45 7C140-45 7C141-45		7C130-55 7C131-55 7C140-55 7C141-55		Unit
		Min	Max	Min	Max	Min	Max	
Read Cycle								
t _{RC}	Read Cycle Time	35		45		55		ns
t _{AA}	Address to Data Valid ^[13]		35		45		55	ns
t _{OHA}	Data Hold from Address Change	0		0		0		ns
t _{ACE}	CE LOW to Data Valid ^[13]		35		45		55	ns
t _{DOE}	OE LOW to Data Valid ^[13]		20		25		25	ns
t _{LZOE}	OE LOW to Low Z ^[10, 14, 15]	3		3		3		ns
t _{HZOE}	OE HIGH to High Z ^[10, 14, 15]		20		20		25	ns
t _{LZCE}	CE LOW to Low Z ^[10, 14, 15]	5		5		5		ns
t _{HZCE}	CE HIGH to High Z ^[10, 14, 15]		20		20		25	ns
t _{PU}	CE LOW to Power Up ^[10]	0		0		0		ns
t _{PD}	CE HIGH to Power Down ^[10]		35		35		35	ns
Write Cycle^[16]								
t _{WC}	Write Cycle Time	35		45		55		ns
t _{SCE}	CE LOW to Write End	30		35		40		ns
t _{AW}	Address Setup to Write End	30		35		40		ns
t _{HA}	Address Hold from Write End	2		2		2		ns
t _{SA}	Address Setup to Write Start	0		0		0		ns
t _{PWE}	R/W Pulse Width	25		30		30		ns
t _{SD}	Data Setup to Write End	15		20		20		ns
t _{HD}	Data Hold from Write End	0		0		0		ns
t _{HZWE}	R/W LOW to High Z ^[15]		20		20		25	ns
t _{LZWE}	R/W HIGH to Low Z ^[15]	0		0		0		ns
Busy/Interrupt Timing								
t _{B_{LA}}	BUSY LOW from Address Match		20		25		30	ns
t _{B_{HA}}	BUSY HIGH from Address Mismatch ^[17]		20		25		30	ns
t _{B_{LC}}	BUSY LOW from CE LOW		20		25		30	ns
t _{B_{HC}}	BUSY HIGH from CE HIGH ^[17]		20		25		30	ns
t _{PS}	Port Set Up for Priority	5		5		5		ns
t _{W_B} ^[18]	R/W LOW after BUSY LOW	0		0		0		ns
t _{W_H}	R/W HIGH after BUSY HIGH	30		35		35		ns
t _{B_{DD}}	BUSY HIGH to Valid Data		35		45		45	ns
t _{D_{DD}}	Write Data Valid to Read Data Valid		Note 19		Note 19		Note 19	ns
t _{W_{DD}}	Write Pulse to Data Delay		Note 19		Note 19		Note 19	ns
Interrupt Timing								
t _{W_{INS}}	R/W to INTERRUPT Set Time		25		35		45	ns
t _{E_{INS}}	CE to INTERRUPT Set Time		25		35		45	ns
t _{I_{NS}}	Address to INTERRUPT Set Time		25		35		45	ns
t _{O_{INR}}	OE to INTERRUPT Reset Time ^[17]		25		35		45	ns
t _{E_{INR}}	CE to INTERRUPT Reset Time ^[17]		25		35		45	ns
t _{I_{NR}}	Address to INTERRUPT Reset Time ^[17]		25		35		45	ns

Switching Waveforms

Figure 5. Read Cycle No. 1^[20, 21]

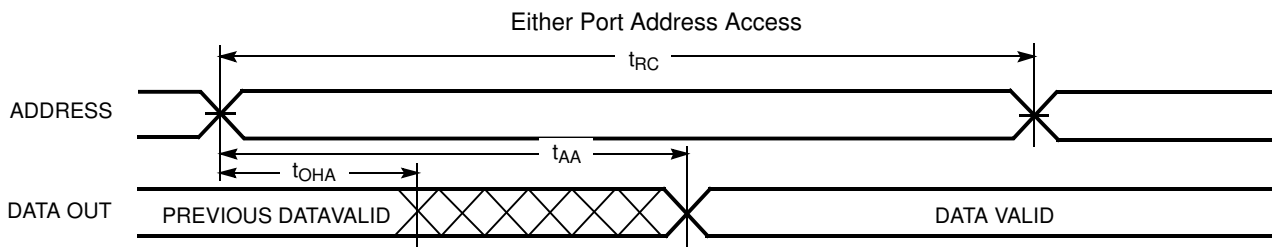

Figure 6. Read Cycle No. 2^[20, 22]

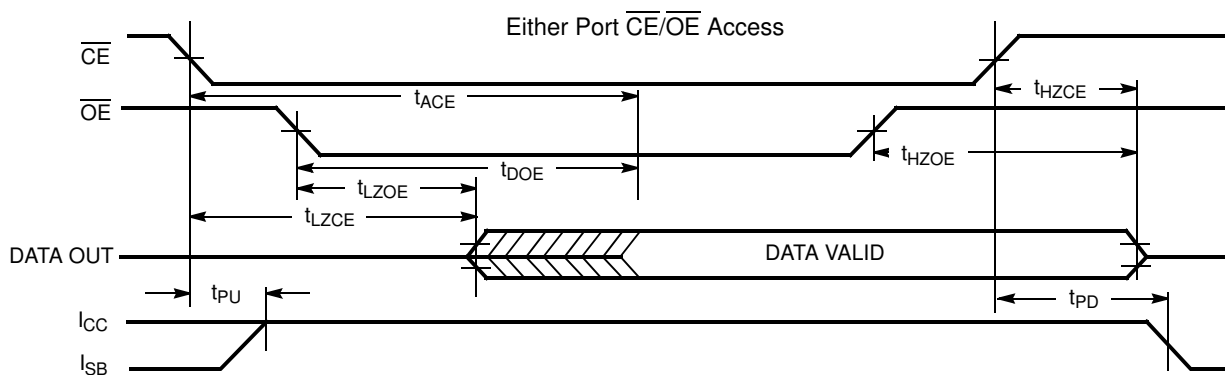
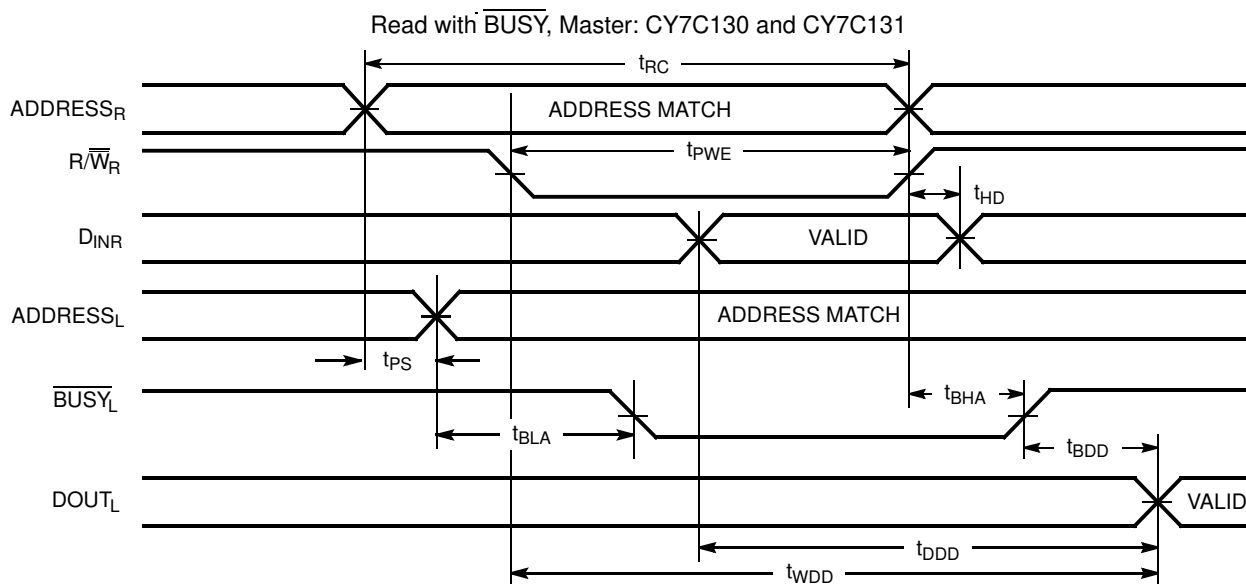

Figure 7. Read Cycle No. 3^[21]



Notes

20. R/\overline{W} is HIGH for read cycle.
21. Device is continuously selected, $\overline{CE} = V_{IL}$ and $\overline{OE} = V_{IL}$.
22. Address valid prior to or coincident with \overline{CE} transition LOW.

Switching Waveforms (continued)

Figure 8. Write Cycle No. 1 (OE Three-States Data I/Os—Either Port)^[16, 23]

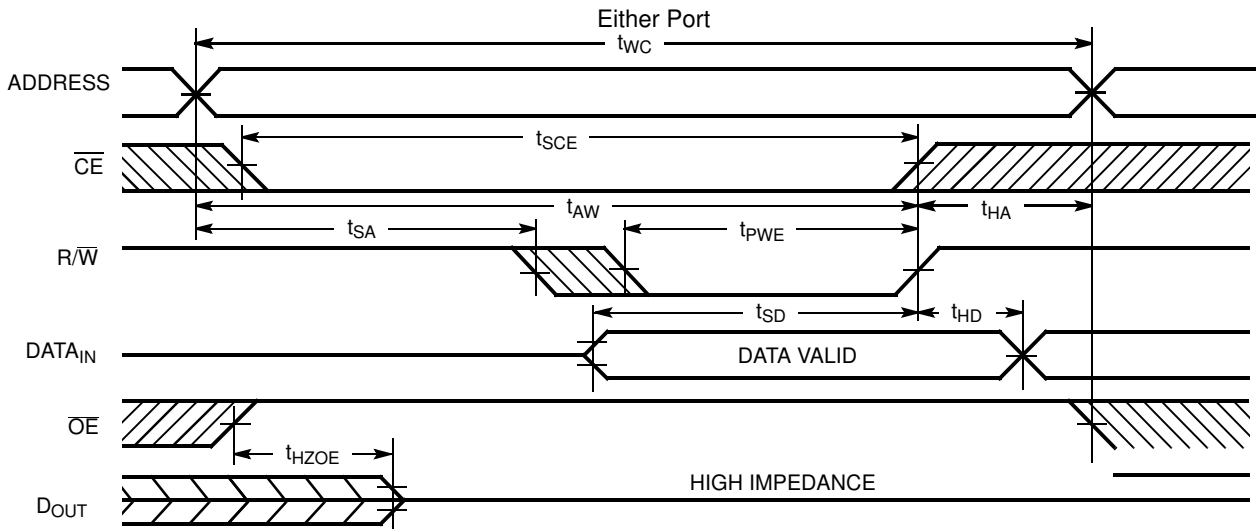
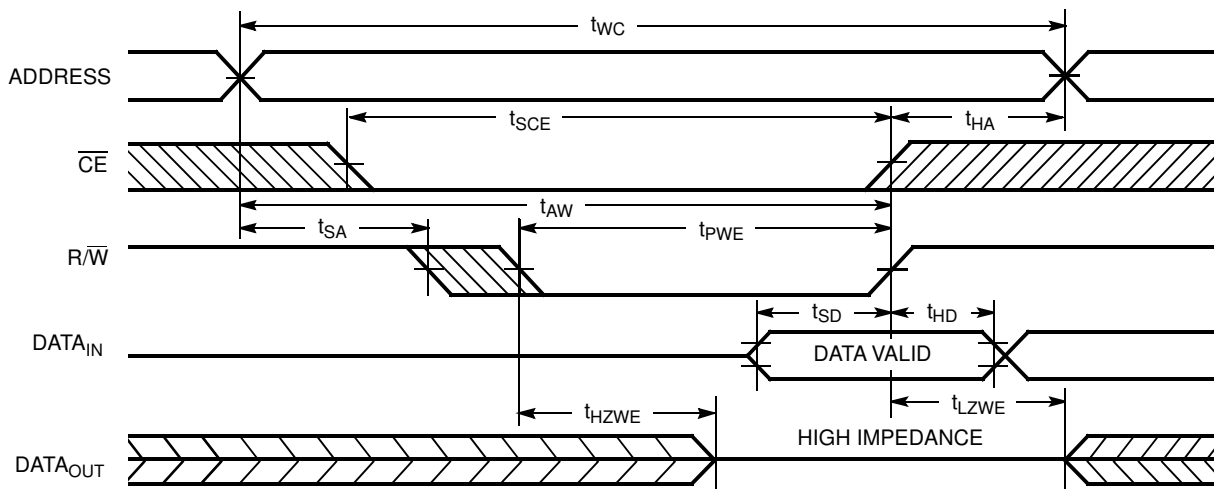

Figure 9. Write Cycle No. 2 (R/W Three-States Data I/Os—Either Port)^[17, 24]



Notes

- 23. If \overline{OE} is LOW during a R/\overline{W} controlled write cycle, the write pulse width must be the larger of t_{pwe} or $t_{hzo} + t_{sd}$ to allow the data I/O pins to enter high impedance and for data to be placed on the bus for the required t_{sd} .
- 24. If the \overline{CE} LOW transition occurs simultaneously with or after the R/\overline{W} LOW transition, the outputs remain in the high impedance state.

Switching Waveforms (continued)

Figure 10. Busy Timing Diagram No. 1 (\overline{CE} Arbitration)

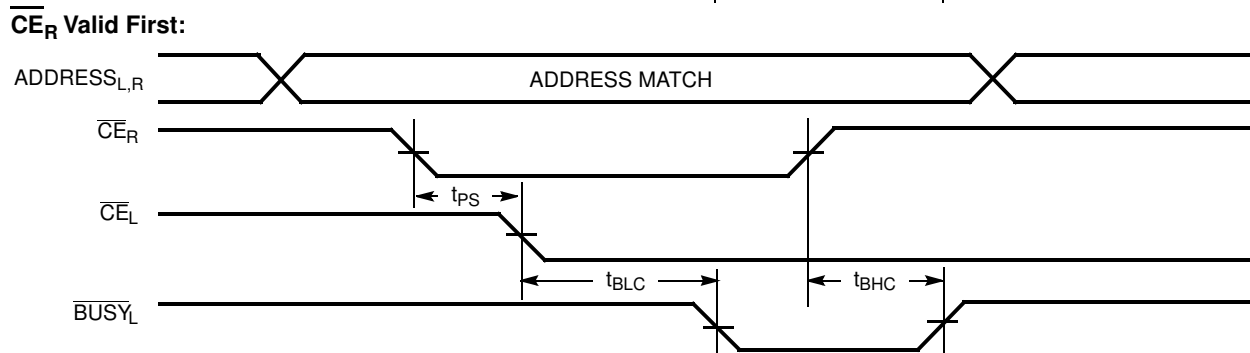
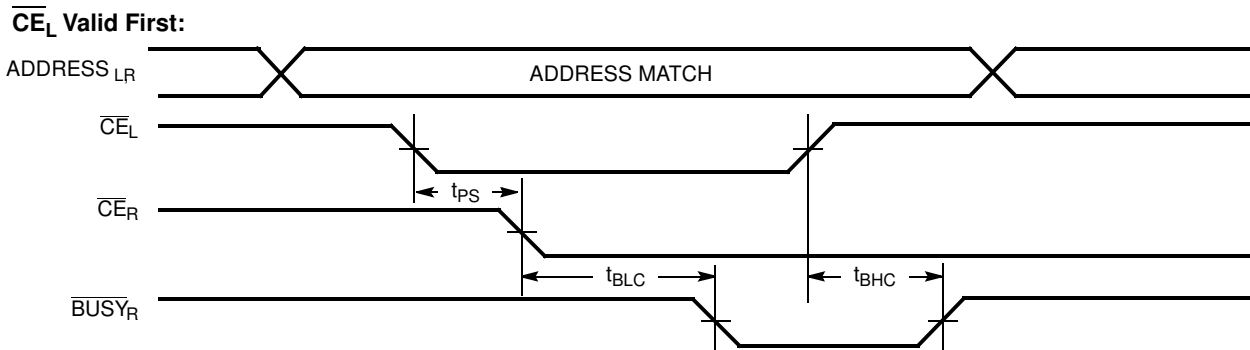
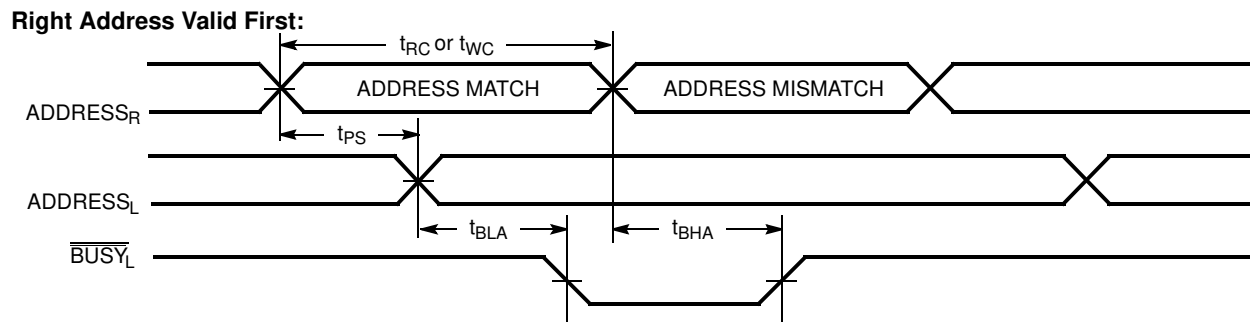
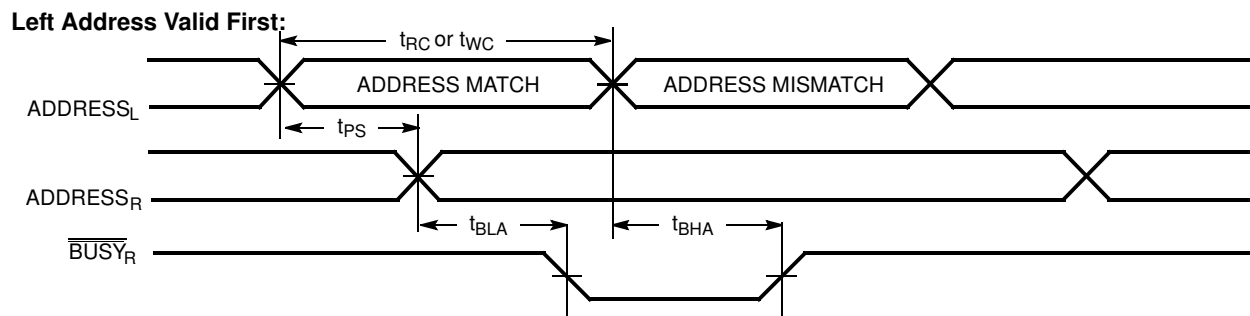

Figure 11. Busy Timing Diagram No. 2 (Address Arbitration)



Switching Waveforms (continued)

Figure 12. Busy Timing Diagram No. 3

Write with $\overline{\text{BUSY}}$ (Slave:CY7C140/CY7C141)

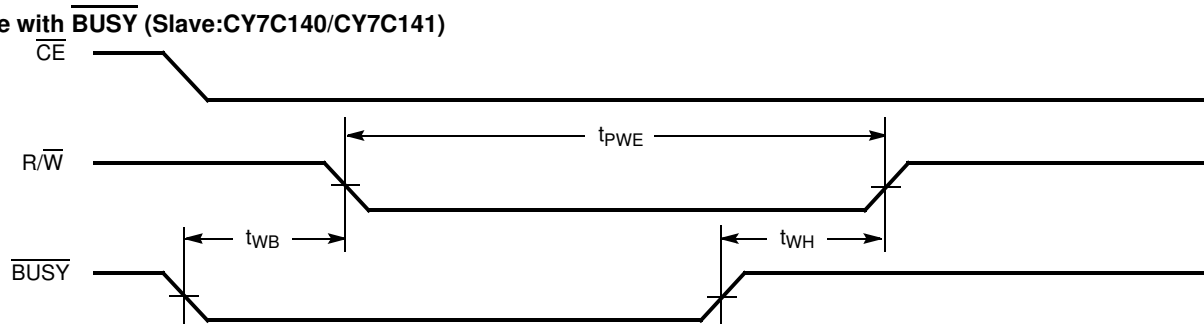

Switching Waveforms (continued)

Figure 13. Interrupt Timing Diagrams

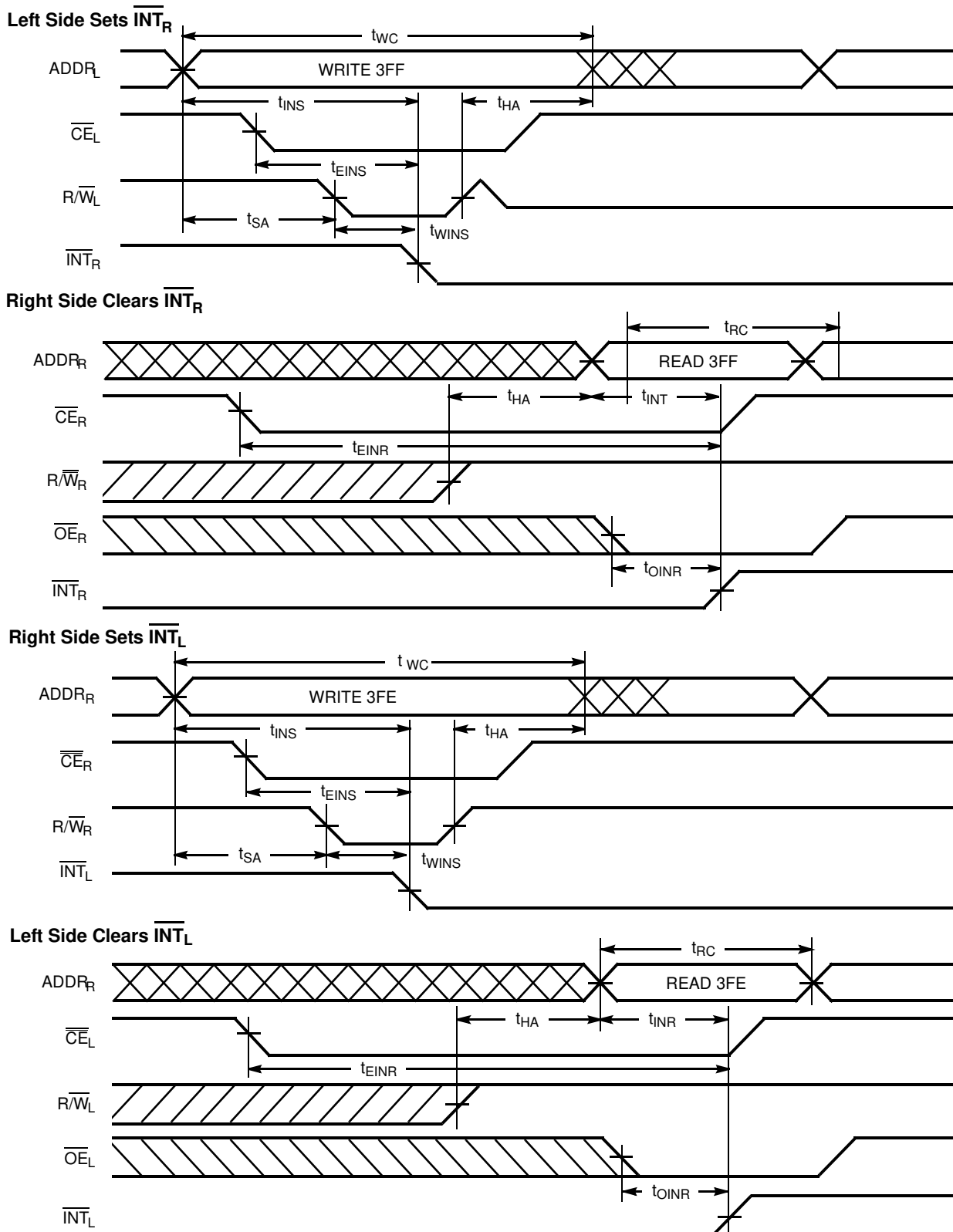

Typical DC and AC Characteristics

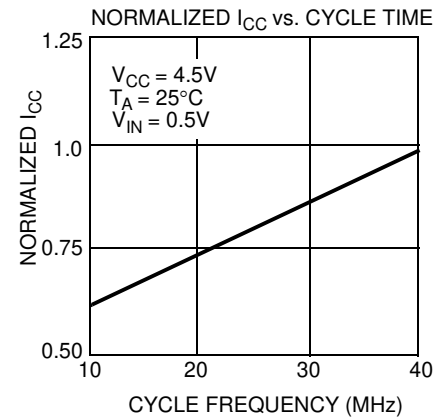
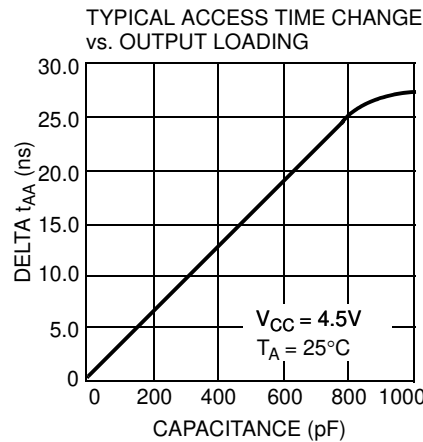
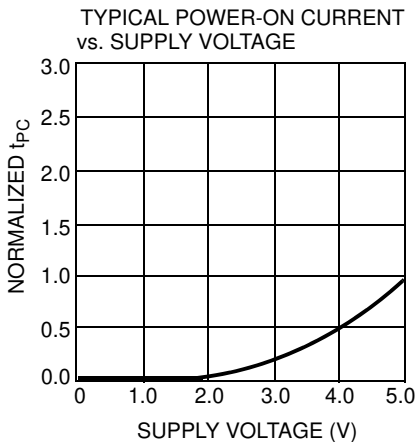
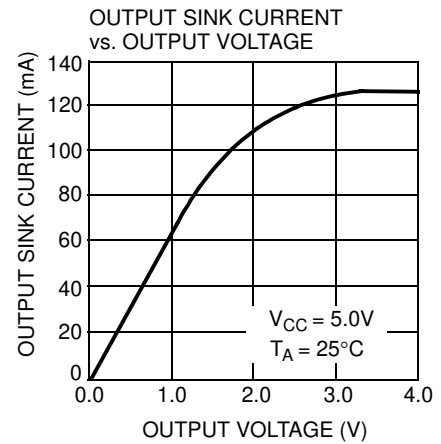
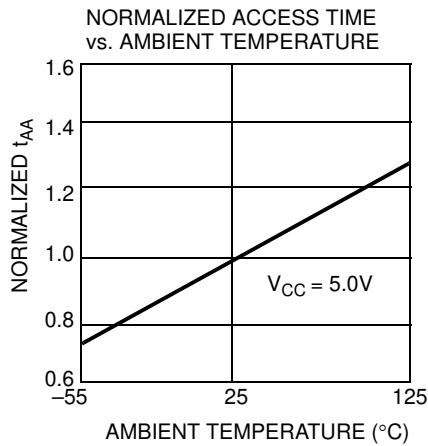
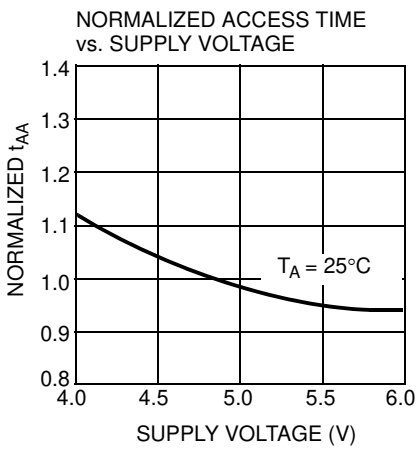
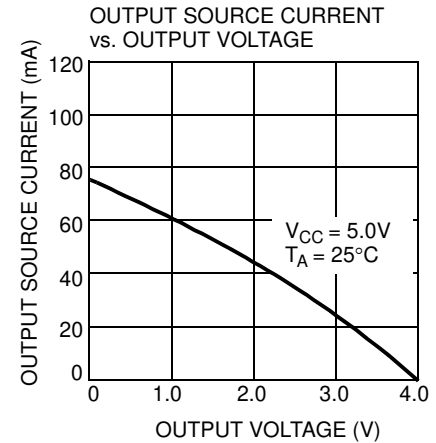
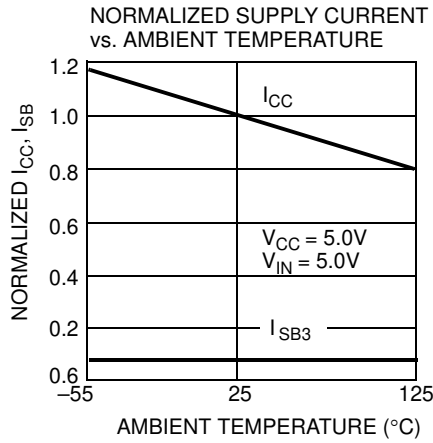
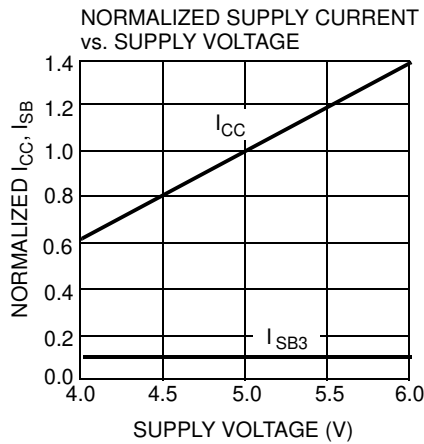

Ordering Information

Speed (ns)	Ordering Code	Package Name	Package Type	Operating Range
30	CY7C130-30PC	P25	48-Pin (600 Mil) Molded DIP	Commercial
	CY7C130A-30PI	P25	48-Pin Pb-Free (600 Mil) Molded DIP	Industrial
35	CY7C130-35PC	P25	48-Pin (600 Mil) Molded DIP	Commercial
	CY7C130-35PI	P25	48-Pin (600 Mil) Molded DIP	Industrial
45	CY7C130-45PC	P25	48-Pin (600 Mil) Molded DIP	Commercial
	CY7C130-45PI	P25	48-Pin (600 Mil) Molded DIP	Industrial
55	CY7C130-55PC	P25	48-Pin (600 Mil) Molded DIP	Commercial
	CY7C130-55PI	P25	48-Pin (600 Mil) Molded DIP	Industrial
15	CY7C131-15JC	J69	52-Pin Plastic Leaded Chip Carrier	Commercial
	CY7C131-15JXC	J69	52-Pin Pb-Free Plastic Leaded Chip Carrier	
	CY7C131-15NC	N52	52-Pin Plastic Quad Flatpack	
	CY7C131-15JI	J69	52-Pin Plastic Leaded Chip Carrier	Industrial
	CY7C131A-15JXI	J69	52-Pin Pb-Free Plastic Leaded Chip Carrier	
	CY7C131-15NXI	N52	52-Pin Pb-Free Plastic Quad Flatpack	
25	CY7C131-25JC	J69	52-Pin Plastic Leaded Chip Carrier	Commercial
	CY7C131-25JXC	J69	52-Pin Pb-Free Plastic Leaded Chip Carrier	
	CY7C131-25NC	N52	52-Pin Plastic Quad Flatpack	
	CY7C131-25NXC	N52	52-Pin Pb-Free Plastic Quad Flatpack	Industrial
	CY7C131-25JI	J69	52-Pin Plastic Leaded Chip Carrier	
	CY7C131-25NI	N52	52-Pin Plastic Quad Flatpack	
30	CY7C131-30JC	J69	52-Pin Plastic Leaded Chip Carrier	Commercial
	CY7C131-30NC	N52	52-Pin Plastic Quad Flatpack	Industrial
	CY7C131-30JI	J69	52-Pin Plastic Leaded Chip Carrier	
35	CY7C131-35JC	J69	52-Pin Plastic Leaded Chip Carrier	Commercial
	CY7C131-35NC	N52	52-Pin Plastic Quad Flatpack	Industrial
	CY7C131-35JI	J69	52-Pin Plastic Leaded Chip Carrier	
	CY7C131-35NI	N52	52-Pin Plastic Quad Flatpack	
45	CY7C131-45JC	J69	52-Pin Plastic Leaded Chip Carrier	Commercial
	CY7C131-45NC	N52	52-Pin Plastic Quad Flatpack	Industrial
	CY7C131-45JI	J69	52-Pin Plastic Leaded Chip Carrier	
	CY7C131-45NI	N52	52-Pin Plastic Quad Flatpack	
55	CY7C131-55JC	J69	52-Pin Plastic Leaded Chip Carrier	Commercial
	CY7C131-55JXC	J69	52-Pin Pb-Free Plastic Leaded Chip Carrier	
	CY7C131-55NC	N52	52-Pin Plastic Quad Flatpack	
	CY7C131-55NXC	N52	52-Pin Pb-Free Plastic Quad Flatpack	
	CY7C131-55JI	J69	52-Pin Plastic Leaded Chip Carrier	Industrial
	CY7C131-55JXI	J69	52-Pin Pb-Free Plastic Leaded Chip Carrier	
	CY7C131-55NI	N52	52-Pin Plastic Quad Flatpack	
	CY7C131-55NXI	N52	52-Pin Pb-Free Plastic Quad Flatpack	
30	CY7C140-30PC	P25	48-Pin (600 Mil) Molded DIP	Commercial
	CY7C140-30PI	P25	48-Pin (600 Mil) Molded DIP	Industrial

Ordering Information (continued)

Speed (ns)	Ordering Code	Package Name	Package Type	Operating Range
35	CY7C140-35PC	P25	48-Pin (600 Mil) Molded DIP	Commercial
	CY7C140-35PI	P25	48-Pin (600 Mil) Molded DIP	Industrial
45	CY7C140-45PC	P25	48-Pin (600 Mil) Molded DIP	Commercial
	CY7C140-45PI	P25	48-Pin (600 Mil) Molded DIP	Industrial
55	CY7C140-55PC	P25	48-Pin (600 Mil) Molded DIP	Commercial
	CY7C140-55PI	P25	48-Pin (600 Mil) Molded DIP	Industrial
15	CY7C141-15JC	J69	52-Pin Plastic Leaded Chip Carrier	Commercial
	CY7C141-15NC	N52	52-Pin Plastic Quad Flatpack	
25	CY7C141-25JC	J69	52-Pin Plastic Leaded Chip Carrier	Commercial
	CY7C141-25JXC	J69	52-Pin Pb-Free Plastic Leaded Chip Carrier	
	CY7C141-25NC	N52	52-Pin Plastic Quad Flatpack	
	CY7C141-25JI	J69	52-Pin Plastic Leaded Chip Carrier	Industrial
	CY7C141-25NI	N52	52-Pin Plastic Quad Flatpack	
30	CY7C141-30JC	J69	52-Pin Plastic Leaded Chip Carrier	Commercial
	CY7C141-30NC	N52	52-Pin Plastic Quad Flatpack	
	CY7C141-30JI	J69	52-Pin Plastic Leaded Chip Carrier	Industrial
35	CY7C141-35JC	J69	52-Pin Plastic Leaded Chip Carrier	Commercial
	CY7C141-35NC	N52	52-Pin Plastic Quad Flatpack	
	CY7C141-35JI	J69	52-Pin Plastic Leaded Chip Carrier	Industrial
	CY7C141-35NI	N52	52-Pin Plastic Quad Flatpack	
45	CY7C141-45JC	J69	52-Pin Plastic Leaded Chip Carrier	Commercial
	CY7C141-45NC	N52	52-Pin Plastic Quad Flatpack	
	CY7C141-45JI	J69	52-Pin Plastic Leaded Chip Carrier	Industrial
	CY7C141-45NI	N52	52-Pin Plastic Quad Flatpack	
55	CY7C141-55JC	J69	52-Pin Plastic Leaded Chip Carrier	Commercial
	CY7C141-55NC	N52	52-Pin Plastic Quad Flatpack	
	CY7C141-55JI	J69	52-Pin Plastic Leaded Chip Carrier	Industrial
	CY7C141-55NI	N52	52-Pin Plastic Quad Flatpack	

Package Diagrams

Figure 14. 48-Pin (600 Mil) Sidebrazed DIP D26

MIL-STD-1835 D-14 Config. C

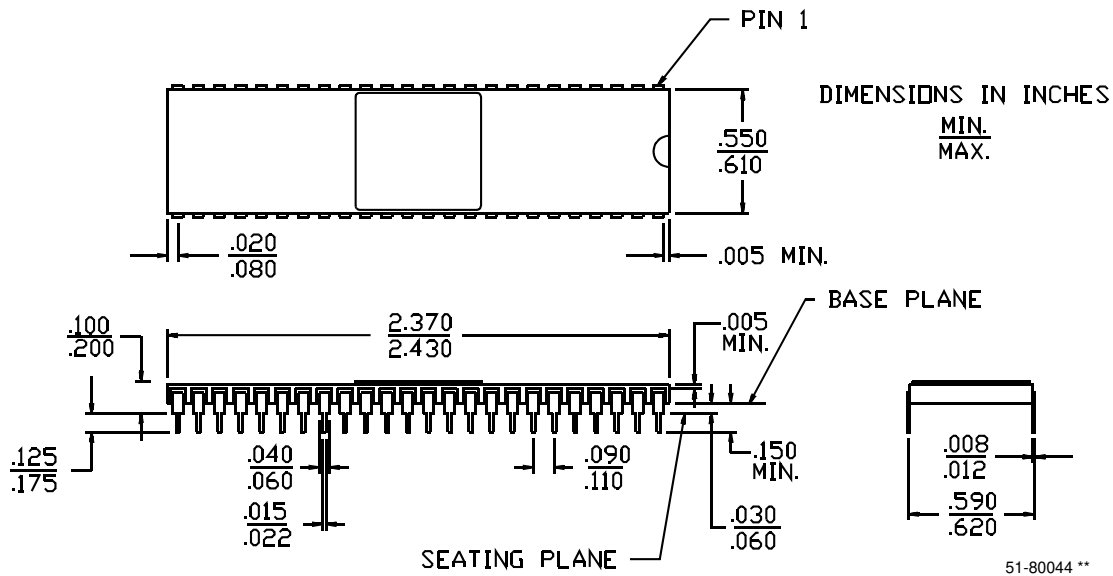
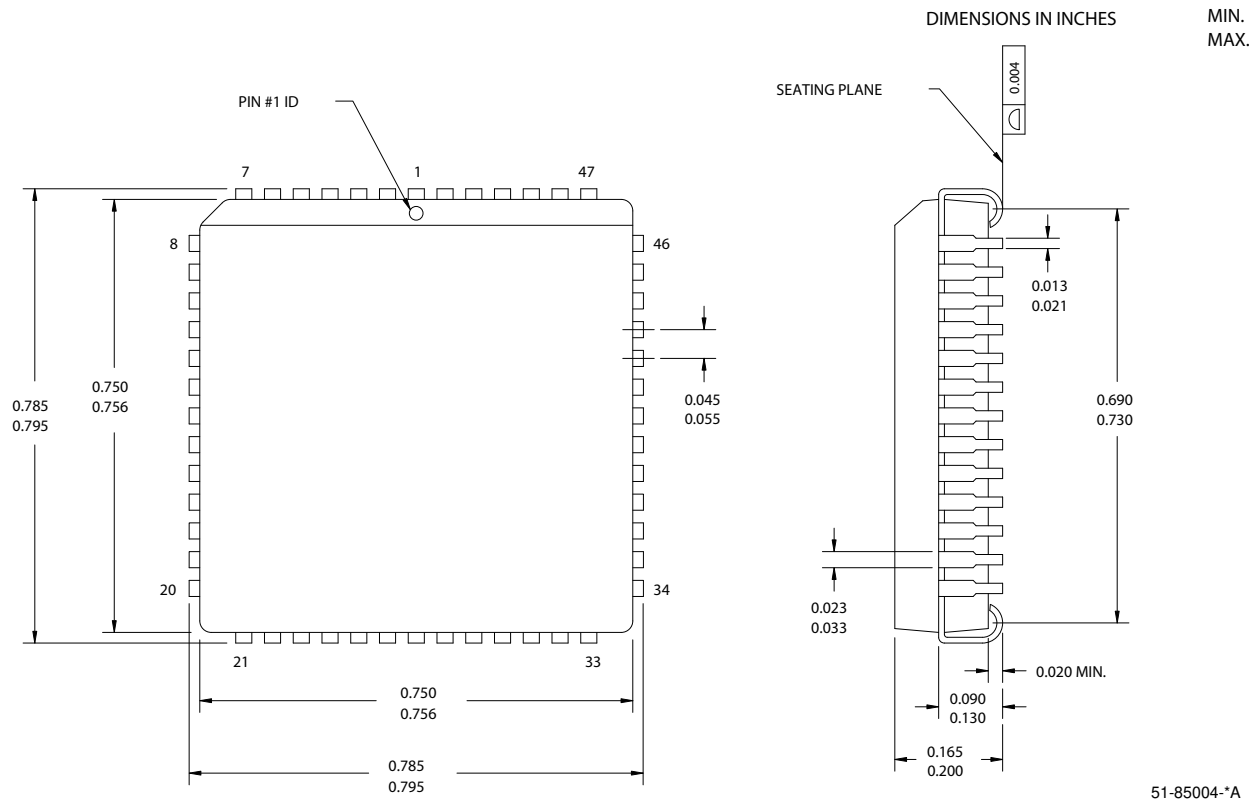

Figure 15. 52-Pin Pb-Free Plastic Leaded Chip Carrier J69



Package Diagrams (continued)

Figure 16. 48-Pin (600 Mil) Molded DIP P25

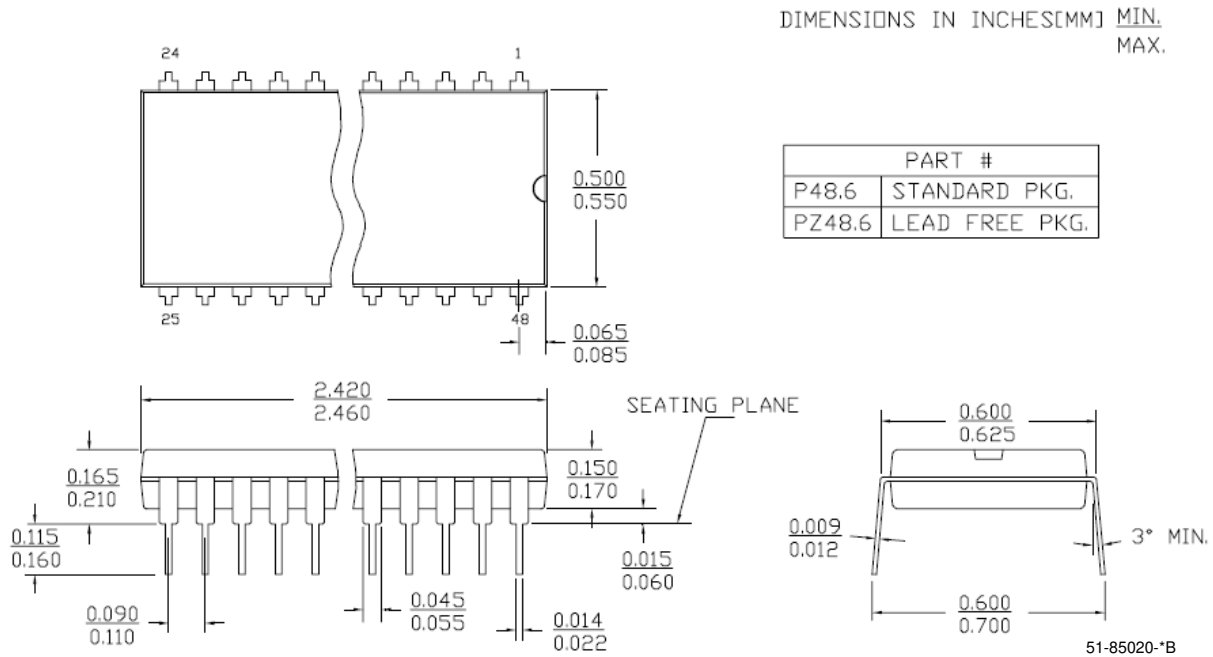
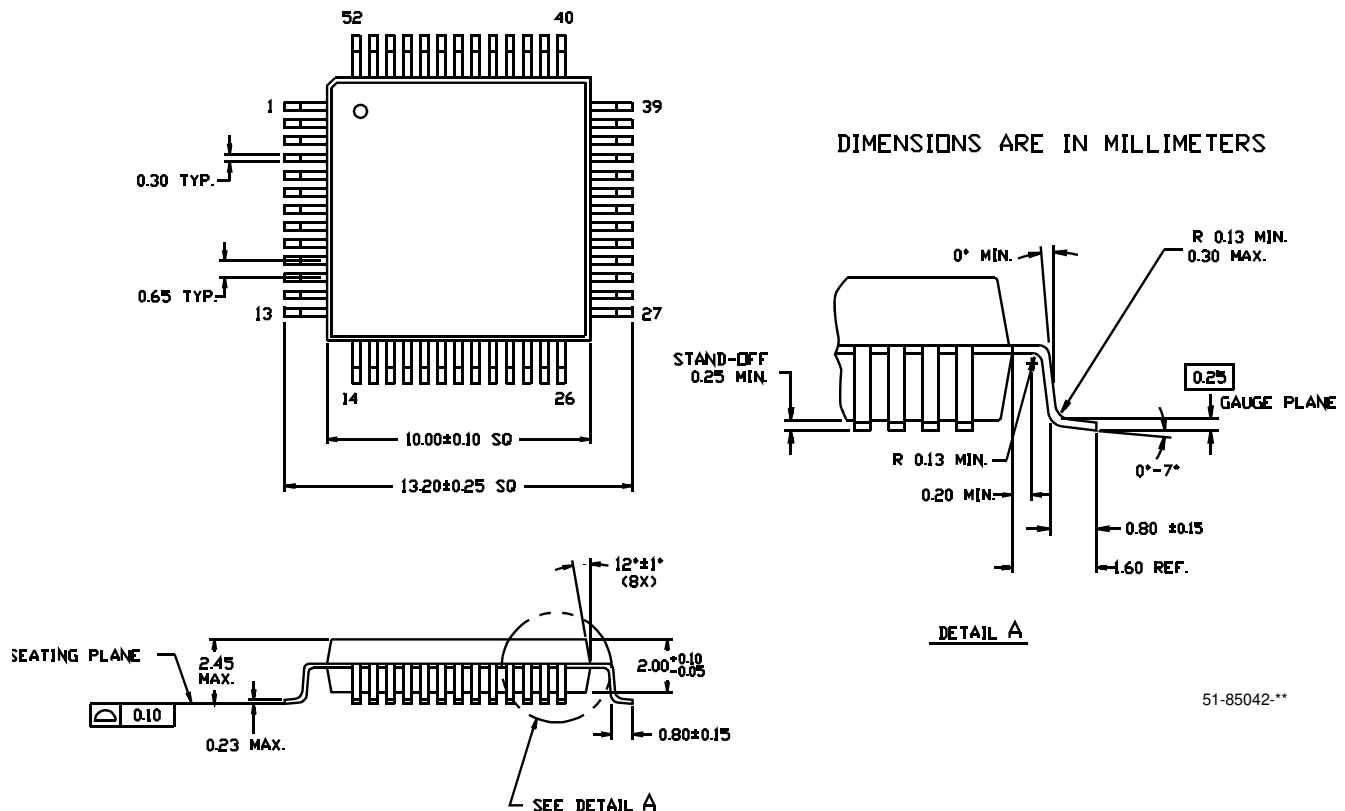

Figure 17. 52-Pin Pb-Free Plastic Quad Flatpack N52



Document History Page

Document Title: CY7C130/CY7C130A/CY7C131/CY7C131A/CY7C140/CY7C141 1K x 8 Dual-Port Static RAM				
Document Number: 38-06002				
Rev.	ECN No.	Orig. of Change	Submission Date	Description of Change
**	110169	SZV	09/29/01	Change from Spec number: 38-00027 to 38-06002
*A	122255	RBI	12/26/02	Power up requirements added to Maximum Ratings Information
*B	236751	YDT	See ECN	Removed cross information from features section
*C	325936	RUY	See ECN	Added pin definitions table, 52-pin PQFP package diagram and Pb-free information
*D	393153	YIM	See ECN	Added CY7C131-15JI to ordering information Added Pb-Free parts to ordering information: CY7C131-15JXI
*E	2623540	VKN/PYRS	12/17/08	Added CY7C130A and CY7C131A parts Removed military information Updated ordering information table

Sales, Solutions, and Legal Information

Worldwide Sales and Design Support

Cypress maintains a worldwide network of offices, solution centers, manufacturer's representatives, and distributors. To find the office closest to you, visit us at cypress.com/sales.

Products

PSoC	psoc.cypress.com
Clocks & Buffers	clocks.cypress.com
Wireless	wireless.cypress.com
Memories	memory.cypress.com
Image Sensors	image.cypress.com

PSoC Solutions

General	psoc.cypress.com/solutions
Low Power/Low Voltage	psoc.cypress.com/low-power
Precision Analog	psoc.cypress.com/precision-analog
LCD Drive	psoc.cypress.com/lcd-drive
CAN 2.0b	psoc.cypress.com/can
USB	psoc.cypress.com/usb

© Cypress Semiconductor Corporation, 2001-2008. The information contained herein is subject to change without notice. Cypress Semiconductor Corporation assumes no responsibility for the use of any circuitry other than circuitry embodied in a Cypress product. Nor does it convey or imply any license under patent or other rights. Cypress products are not warranted nor intended to be used for medical, life support, life saving, critical control or safety applications, unless pursuant to an express written agreement with Cypress. Furthermore, Cypress does not authorize its products for use as critical components in life-support systems where a malfunction or failure may reasonably be expected to result in significant injury to the user. The inclusion of Cypress products in life-support systems application implies that the manufacturer assumes all risk of such use and in doing so indemnifies Cypress against all charges.

Any Source Code (software and/or firmware) is owned by Cypress Semiconductor Corporation (Cypress) and is protected by and subject to worldwide patent protection (United States and foreign), United States copyright laws and international treaty provisions. Cypress hereby grants to licensee a personal, non-exclusive, non-transferable license to copy, use, modify, create derivative works of, and compile the Cypress Source Code and derivative works for the sole purpose of creating custom software and or firmware in support of licensee product to be used only in conjunction with a Cypress integrated circuit as specified in the applicable agreement. Any reproduction, modification, translation, compilation, or representation of this Source Code except as specified above is prohibited without the express written permission of Cypress.

Disclaimer: CYPRESS MAKES NO WARRANTY OF ANY KIND, EXPRESS OR IMPLIED, WITH REGARD TO THIS MATERIAL, INCLUDING, BUT NOT LIMITED TO, THE IMPLIED WARRANTIES OF MERCHANTABILITY AND FITNESS FOR A PARTICULAR PURPOSE. Cypress reserves the right to make changes without further notice to the materials described herein. Cypress does not assume any liability arising out of the application or use of any product or circuit described herein. Cypress does not authorize its products for use as critical components in life-support systems where a malfunction or failure may reasonably be expected to result in significant injury to the user. The inclusion of Cypress' product in a life-support systems application implies that the manufacturer assumes all risk of such use and in doing so indemnifies Cypress against all charges.

Use may be limited by and subject to the applicable Cypress software license agreement.