

MATERIALS & SPECIFICATIONS

PART NO.	A 79110-001	REV	ECO	DATE	APP
		E	99295	02-21-13	TLM

- INSULATOR MATERIAL:**
THERMOPLASTIC POLYMER PER MIL-DTL-32139
- CONTACT MATERIAL:**
COPPER ALLOY PER MIL-DTL-32139. GOLD PLATED PER ASTM B488, (HARD GOLD) TYPE II CODE C CLASS 1.27
- TERMINATION:**
SOLDER COATED WITH SN63 PER J-STD-006 OR SN60 PER AMS-P-81728
- CURRENT CAPACITY:**
1 AMP MAX PER MIL-DTL-32139
- CONTACT RESISTANCE:**
71 MILLIOHMS (71 mV) MAX @ 1.0 AMPS PER MIL-DTL-32139

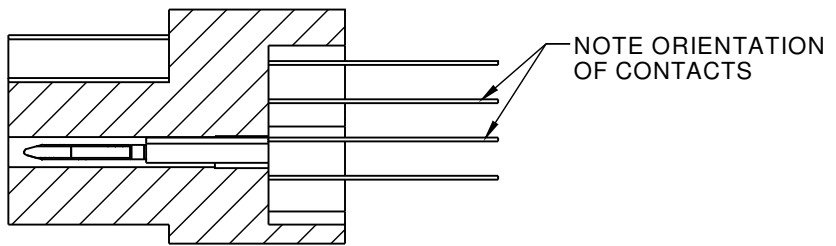
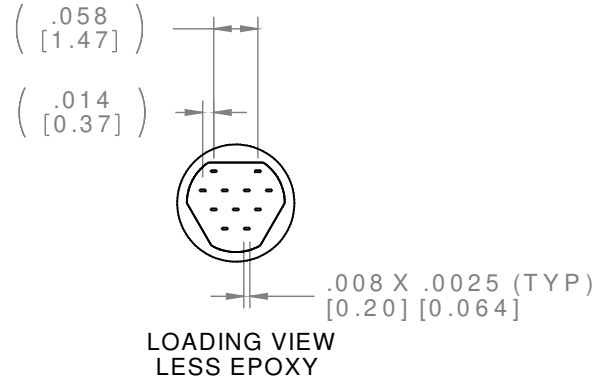
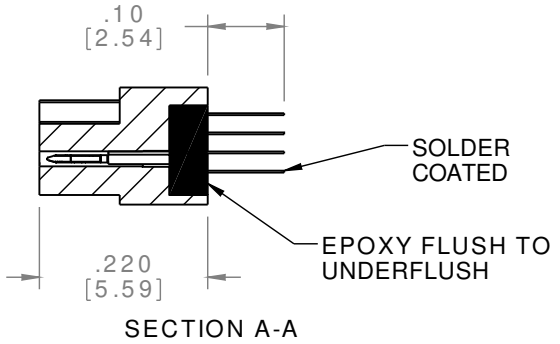
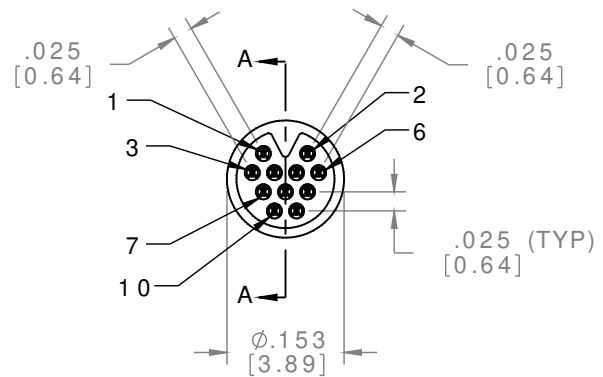
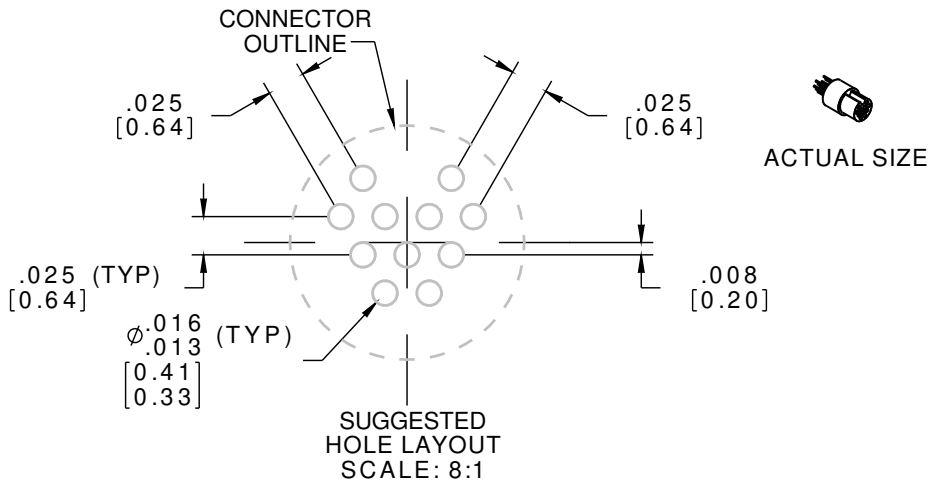

VIEW
LESS EPOXY
SCALE 8:1

NCP SLDW	THIRD ANGLE
	-TOLERANCES-
	UNLESS OTHERWISE NOTED
	DIMENSIONS IN INCHES
2	PL DEC ± .01
3	PL DEC ± .005
4	PL DEC ± .0005
	ANGLES ± 1°

THIS DRAWING CONTAINS CONFIDENTIAL AND PROPRIETARY INFORMATION WHICH IS THE PROPERTY OF OMNETICS CONNECTOR CORP. THIS DOCUMENT MAY NOT, IN WHOLE OR IN PART, BE DUPLICATED, OR DISCLOSED FOR ANY PURPOSE, WITHOUT WRITTEN PERMISSION FROM OMNETICS CONNECTOR CORP.	
DFTM. ACM	DATE 01-22-09
CHK'D.	DATE
APP'D.	DATE
TITLE: (11) PIN MALE NANO CIRCULAR CONNECTOR	

OMNETICS
CONNECTOR CORPORATION
7260 COMMERCE CIRCLE EAST
MINNEAPOLIS, MN 55432
WWW.OMNETICS.COM

CAGE CODE 61873
DWG NO. A79110-001
SHEET 1 OF 1
SCALE: 4:1
REV E