

FEATURES

Conversion loss of up to 8.5 dB (typical)
LO to RF Isolation: 38 dB (typical)
Input IP3 of up to 20 dBm (typical)
RoHS compliant, 7-pad, bare die CHIP

APPLICATIONS

Microwave and very small aperture terminal (VSAT) radios
Test equipment
Military electronic warfare (EW), electronic countermeasure (ECM), and command, control, communications and intelligence (C3I)

GENERAL DESCRIPTION

The HMC554ACHIPS is a general-purpose, double-balanced mixer that can be used as an upconverter or a downconverter between 10 GHz and 20 GHz. This mixer is fabricated in a gallium arsenide (GaAs), metal semiconductor field effect transistor (MESFET) process and requires no external

FUNCTIONAL BLOCK DIAGRAM

Figure 1.

components or matching circuitry. The HMC554ACHIPS optimized balun structures provide high local oscillator (LO) to RF isolation and LO to intermediate frequency (IF) isolation, 38 dB and 52 dB, respectively.

TABLE OF CONTENTS

Features	1	Isolation and Return Loss	19
Applications.....	1	IF Bandwidth—Downconverter.....	21
Functional Block Diagram	1	Spurious and Harmonics Performance	23
General Description	1	Theory of Operation	24
Revision History	2	Applications Information	25
Specifications.....	3	Typical Application Circuit.....	25
Absolute Maximum Ratings.....	4	Mounting and Bonding Techniques	26
ESD Caution.....	4	Handling Precautions	26
Pin Configuration and Function Descriptions.....	5	Mounting.....	26
Interface Schematics.....	5	Wire Bonding.....	26
Typical Performance Characteristics	6	Assembly Diagram	27
Downconverter Performance, IF = 100 MHz.....	6	Outline Dimensions	28
Downconverter Performance, IF = 3000 MHz	10	Ordering Guide	28
Upconverter Performance, IF = 100 MHz	13		
Upconverter Performance, IF = 3000 MHz.....	16		

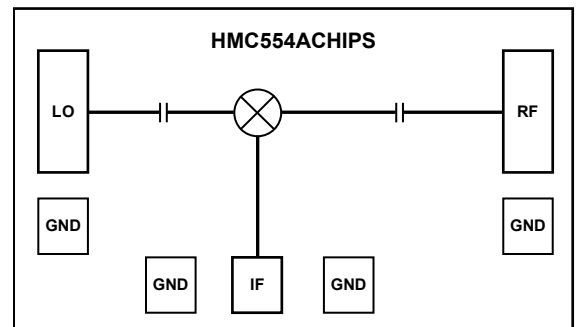
REVISION HISTORY

10/2019—Revision 0: Initial Version

SPECIFICATIONS

$T_A = 25^\circ\text{C}$, $IF = 100\text{ MHz}$, and $LO = 13\text{ dBm}$ for upper sideband. All measurements were performed as a downconverter, unless otherwise noted, on the evaluation printed circuit board (PCB).

Table 1.

Parameter	Test Conditions/Comments	Min	Typ	Max	Unit
FREQUENCY					
RF Pad		10		20	GHz
IF Pad		DC		6	GHz
LO Pad		10		20	GHz
LO AMPLITUDE					
		9	13	15	dBm
10 GHz to 20 GHz PERFORMANCE					
Downconverter					
Conversion Loss			8.5	10	dB
Single Sideband Noise Figure	Measurement taken with external LO amplifier		8.5		dB
Input Third-Order Intercept (IP3)	1 MHz separation between inputs	17	20		dBm
Input 1 dB Compression Point (P1dB)			12		dBm
Input Second-Order Intercept (IP2)	1 MHz separation between inputs		57		dBm
Upconverter					
Conversion Loss			7.5		dB
Input IP3	1 MHz separation between inputs		19		dBm
Input P1dB			8.5		dBm
Isolation					
RF to IF		28	40		dB
LO to RF		30	38		dB
LO to IF		32	52		dB
12 GHz to 16 GHz PERFORMANCE					
Downconverter					
Conversion Loss			8	9	dB
Single Sideband Noise Figure	Measurement taken with external LO amplifier		8		dB
Input IP3	1 MHz separation between inputs	18	20		dBm
Input P1dB			11		dBm
Input IP2	1 MHz separation between inputs		57		dBm
Upconverter					
Conversion Loss			7		dB
Input IP3	1 MHz separation between inputs		18.5		dBm
Input P1dB			9		dBm
Isolation					
RF to IF		38	43		dB
LO to RF		33	38		dB
LO to IF		45	62		dB

ABSOLUTE MAXIMUM RATINGS

Table 2.

Parameter	Rating
RF Input Power	25 dBm
LO Input Power	26 dBm
IF Input Power	25 dBm
IF Source/Sink Current	3 mA
Reflow Temperature	260 °C
Junction Temperature	175°C
Continuous Power Dissipation (P_{DISS}) ($T_A = 85^\circ\text{C}$, Derate 3.7 mW/°C Above 85°C)	333 mW
Operating Temperature Range	-40°C to +85°C
Storage Temperature Range	-65°C to +150°C
Electrostatic Discharge (ESD) Sensitivity	
Human Body Model (HBM)	250 V, Class 1A
Field Induced Charged Device Model (FICDM)	1250 V, Class IV

Stresses at or above those listed under Absolute Maximum Ratings may cause permanent damage to the product. This is a stress rating only; functional operation of the product at these or any other conditions above those indicated in the operational section of this specification is not implied. Operation beyond the maximum operating conditions for extended periods may affect product reliability.

ESD CAUTION



ESD (electrostatic discharge) sensitive device. Charged devices and circuit boards can discharge without detection. Although this product features patented or proprietary protection circuitry, damage may occur on devices subjected to high energy ESD. Therefore, proper ESD precautions should be taken to avoid performance degradation or loss of functionality.

PIN CONFIGURATION AND FUNCTION DESCRIPTIONS

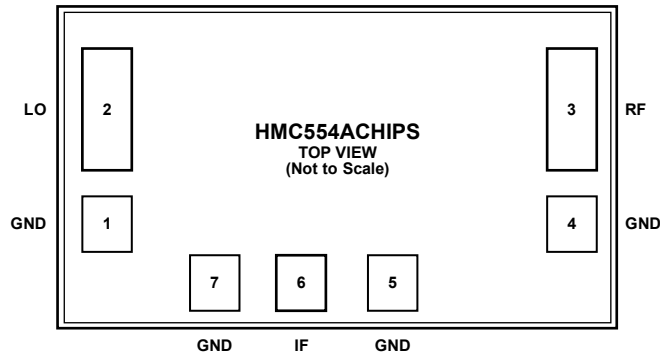

Figure 2. Pad Configuration

Table 3. Pad Function Descriptions

Pad No.	Mnemonic	Description
1, 4, 5, 7	GND	Ground. These pads must be connected to RF and dc ground.
2	LO	LO Port. This pad is ac-coupled and matched to 50 Ω.
3	RF	RF Port. This pad is ac-coupled and matched to 50 Ω.
6	IF	IF Port. This pad is dc-coupled. For applications not requiring operation to dc, dc block this port externally using a series capacitor of a value chosen to pass the necessary IF frequency range. For operation to dc, this pad must not source or sink more than 3 mA of current because die malfunction and possible die failure may result.
Die Bottom	GND	Ground. The die bottom must be attached directly to the ground plane eutectically or with conductive epoxy.

INTERFACE SCHEMATICS



Figure 3. GND Interface Schematic

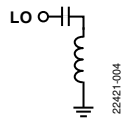

Figure 4. LO Interface Schematic

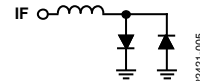

Figure 5. IF Interface Schematic

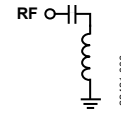

Figure 6. RF Interface Schematic

TYPICAL PERFORMANCE CHARACTERISTICS

DOWNCONVERTER PERFORMANCE, IF = 100 MHz

Upper Sideband (Low-Side LO)

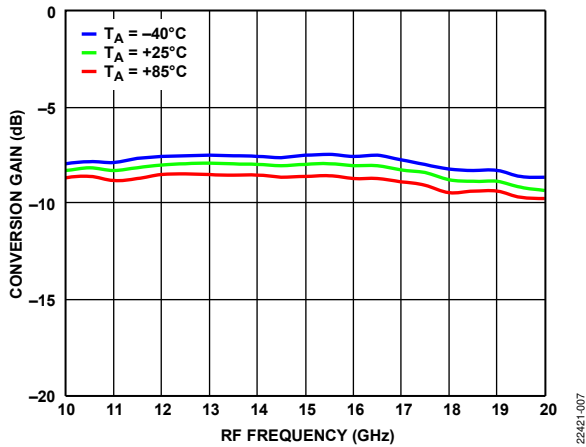

Figure 7. Conversion Gain vs. RF Frequency at Various Temperatures, LO = 13 dBm

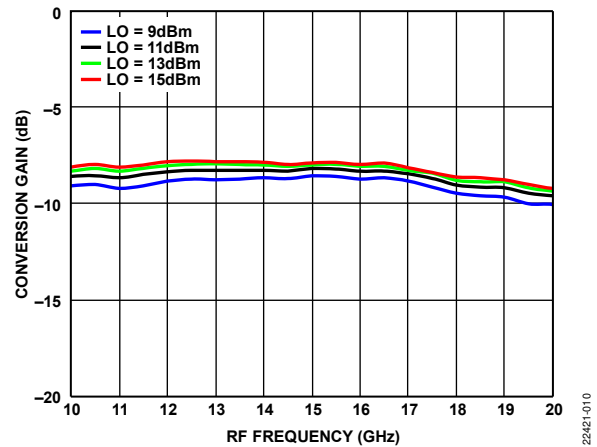

Figure 10. Conversion Gain vs. RF Frequency at Various LO Power Levels, $T_A = 25^\circ\text{C}$

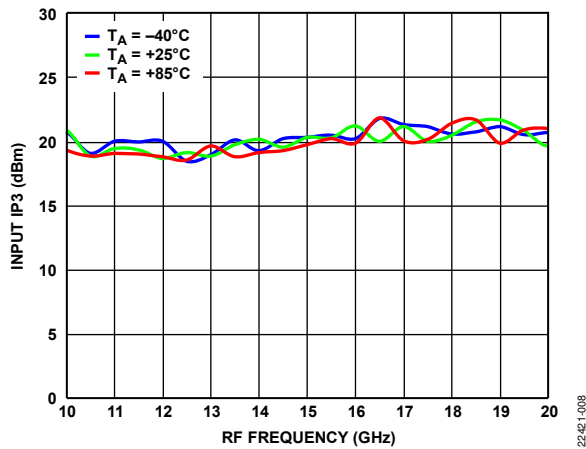

Figure 8. Input IP3 vs. RF Frequency at Various Temperatures, LO = 13 dBm

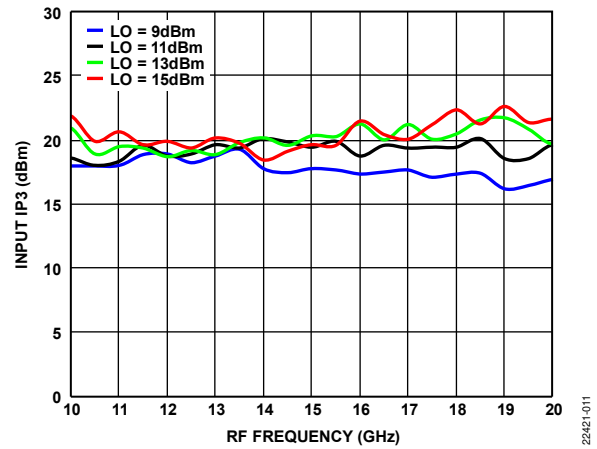

Figure 11. Input IP3 vs. RF Frequency at Various LO Power Levels, $T_A = 25^\circ\text{C}$

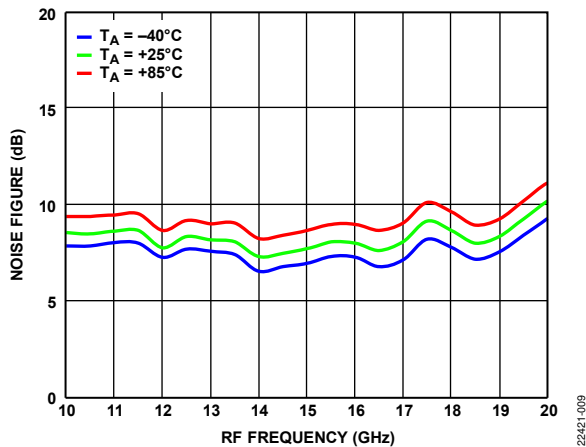

Figure 9. Noise Figure vs. RF Frequency at Various Temperatures, LO = 13 dBm, Measurement Taken with External LO Amplifier

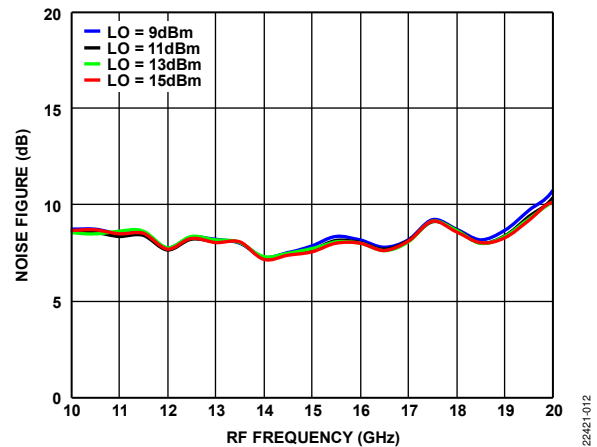

Figure 12. Noise Figure vs. RF Frequency at Various LO Power Levels, $T_A = 25^\circ\text{C}$, Measurement Taken with External LO Amplifier

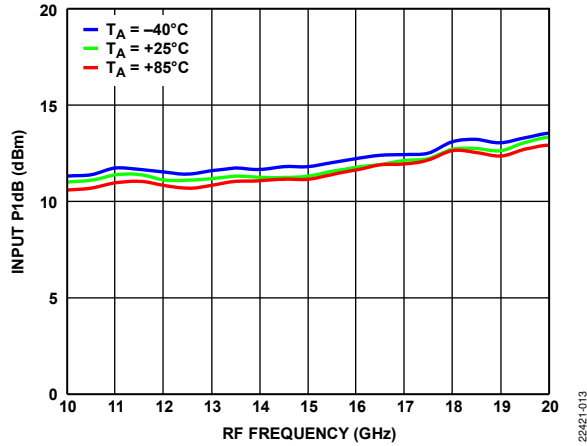

Figure 13. Input P1dB vs. RF Frequency at Various Temperatures, LO = 13 dBm

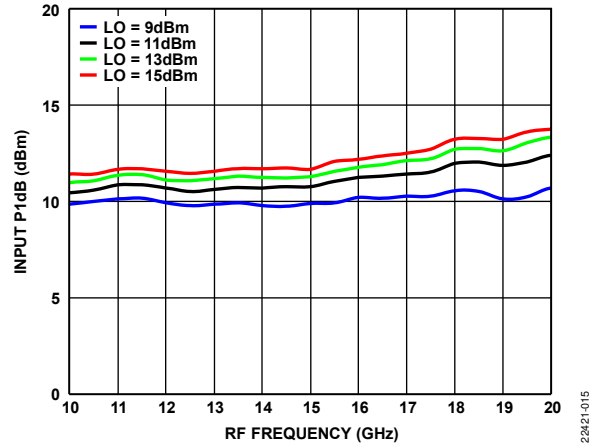

Figure 15. Input P1dB vs. RF Frequency at Various LO Power Levels, TA = 25°C

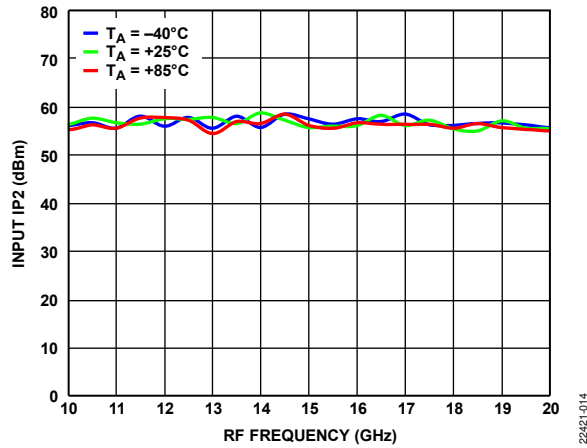

Figure 14. Input IP2 vs. RF Frequency at Various Temperatures, LO = 13 dBm

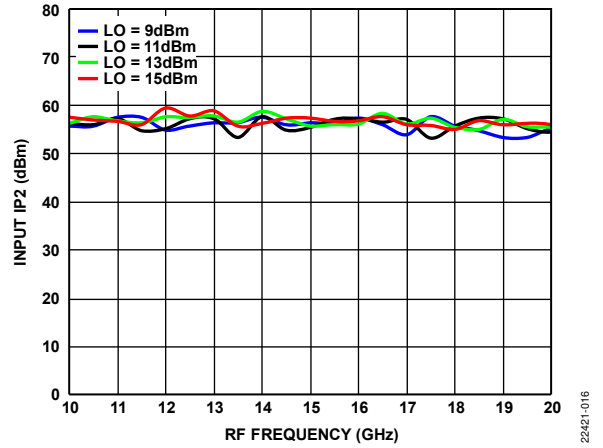

Figure 16. Input IP2 vs. RF Frequency at Various LO Power Levels, TA = 25°C

Lower Sideband (High-Side LO)

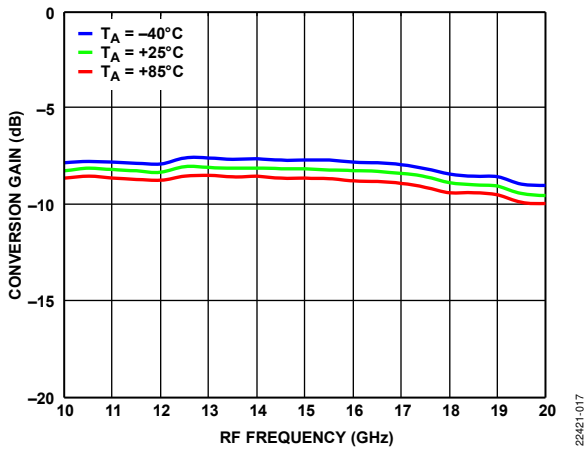

Figure 17. Conversion Gain vs. RF Frequency at Various Temperatures, LO = 13 dBm

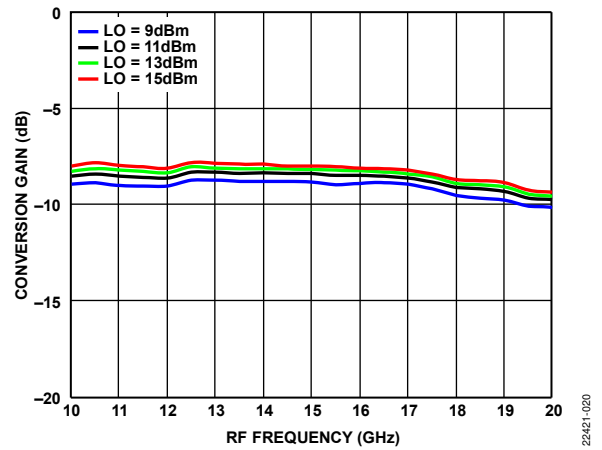

Figure 20. Conversion Gain vs. RF Frequency at Various LO Power Levels, $T_A = 25^\circ\text{C}$

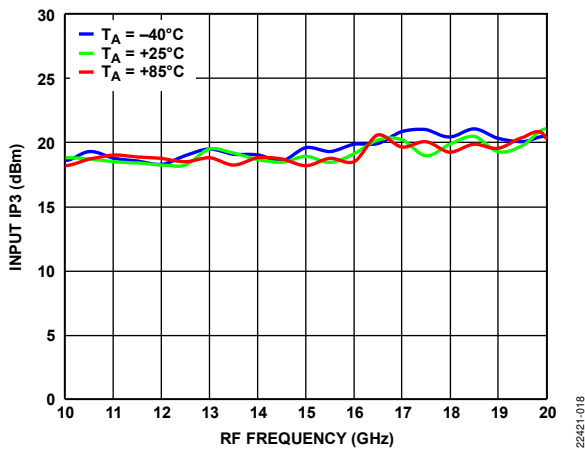

Figure 18. Input IP3 vs. RF Frequency at Various Temperatures, LO = 13 dBm

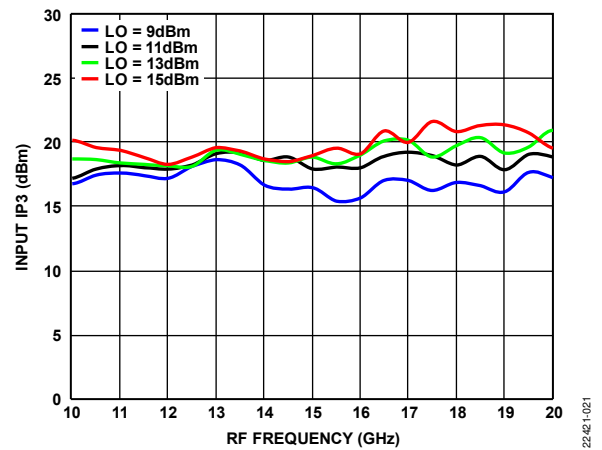

Figure 21. Input IP3 vs. RF Frequency at Various LO Power Levels, $T_A = 25^\circ\text{C}$

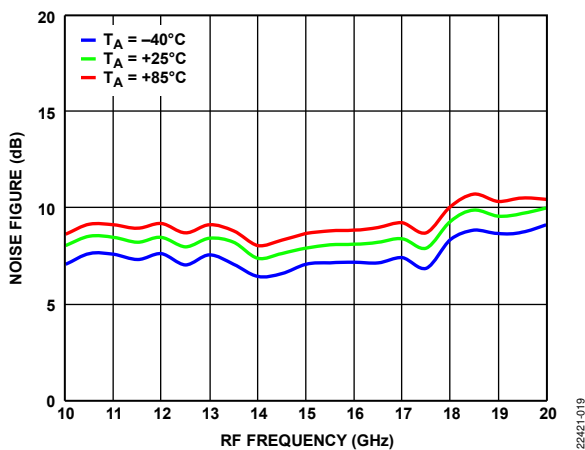

Figure 19. Noise Figure vs. RF Frequency at Various Temperatures, LO = 13 dBm, Measurement Taken with External LO Amplifier

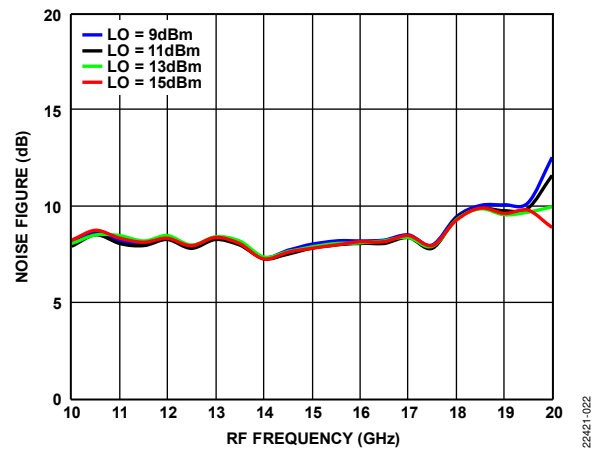

Figure 22. Noise Figure vs. RF Frequency at Various LO Power Levels, $T_A = 25^\circ\text{C}$, Measurement Taken with External LO Amplifier

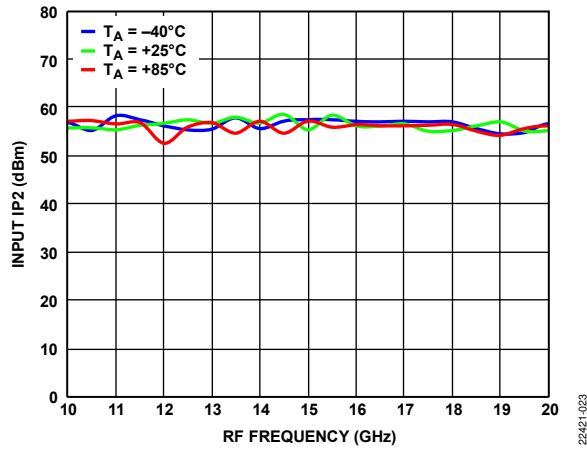

Figure 23. Input IP2 vs. RF Frequency at Various Temperatures, LO = 13 dBm

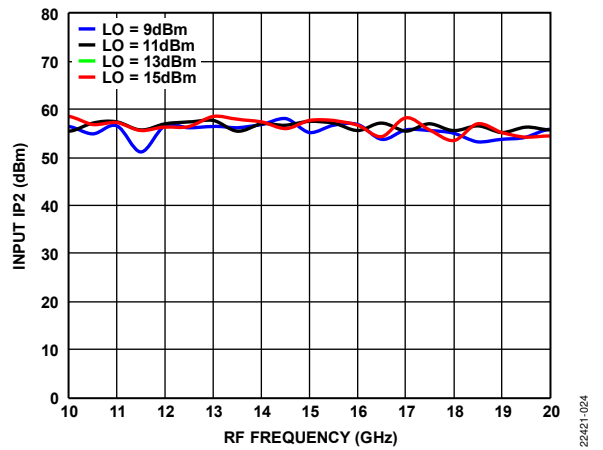

Figure 24. Input IP2 vs. RF Frequency at Various LO Power Levels, $T_A = 25^\circ\text{C}$

DOWNCONVERTER PERFORMANCE, IF = 3000 MHz
Upper Sideband (Low-Side LO)

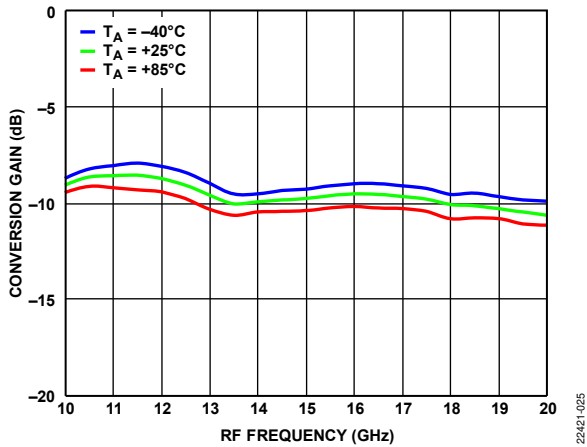

Figure 25. Conversion Gain vs. RF Frequency at Various Temperatures, LO = 13 dBm

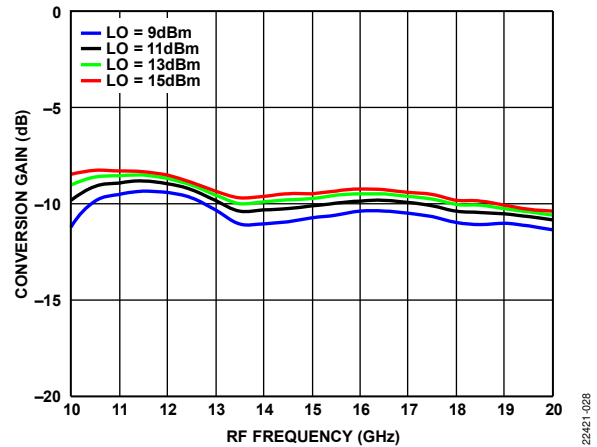

Figure 28. Conversion Gain vs. RF Frequency at Various LO Power Levels, TA = 25°C

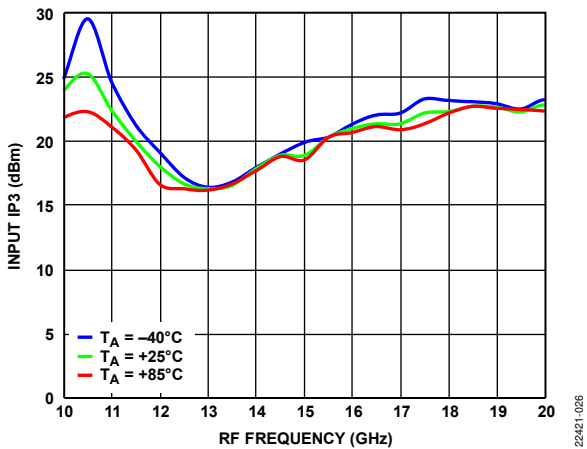

Figure 26. Input IP3 vs. RF Frequency at Various Temperatures, LO = 13 dBm

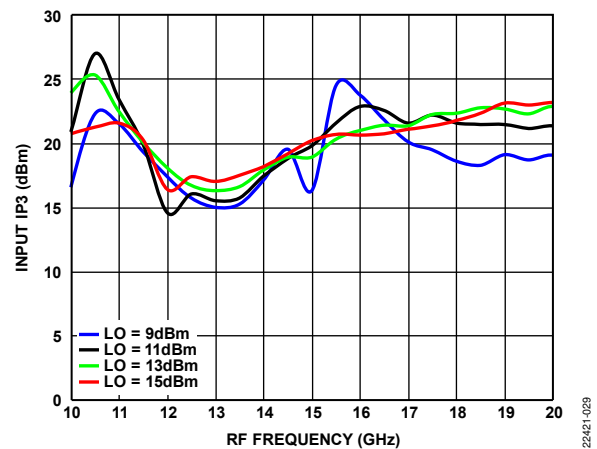

Figure 29. Input IP3 vs. RF Frequency at Various LO Power Levels, TA = 25°C

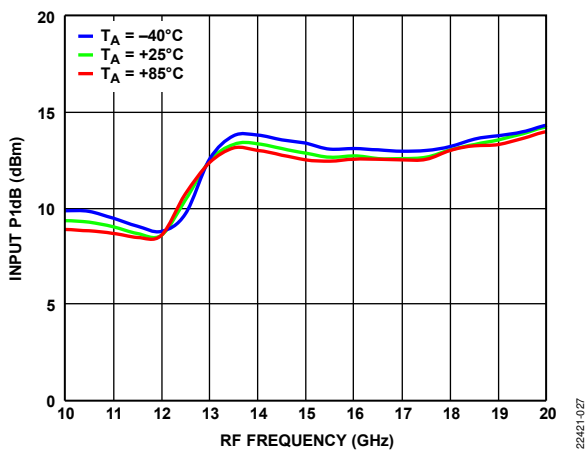

Figure 27. Input P1dB vs. RF Frequency at Various Temperatures, LO = 13 dBm

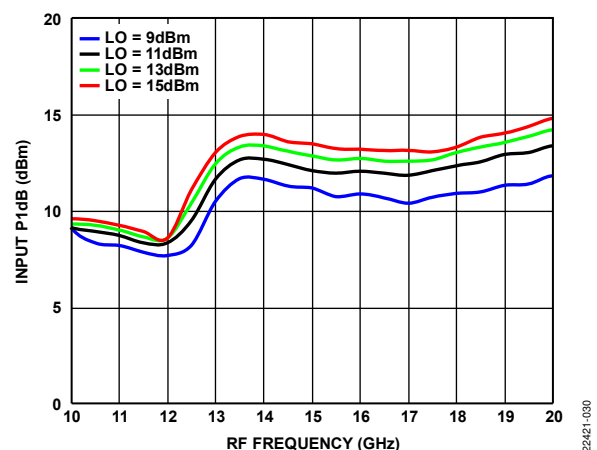

Figure 30. Input P1dB vs. RF Frequency at Various LO Power Levels, TA = 25°C

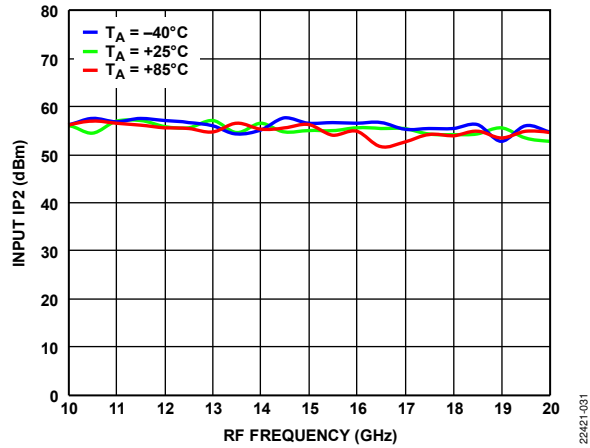

Figure 31. Input IP2 vs. RF Frequency at Various Temperatures, LO = 13 dBm

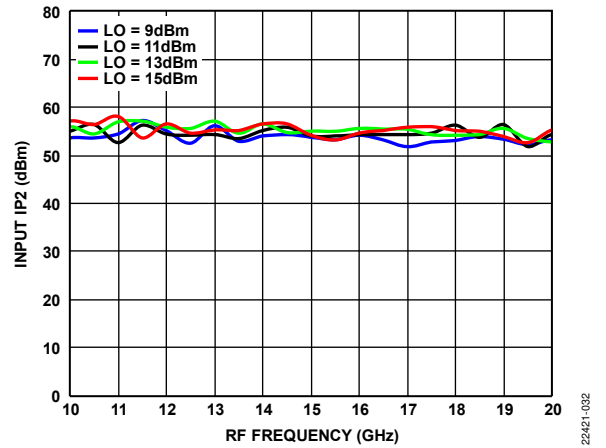

Figure 32. Input IP2 vs. RF Frequency at Various LO Power Levels, $T_A = 25^\circ\text{C}$

Lower Sideband (High-Side LO)

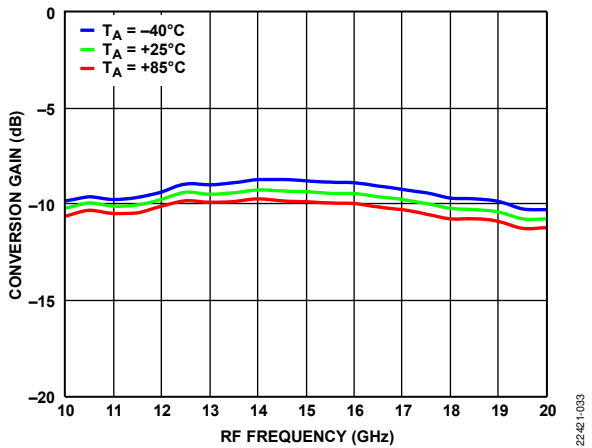

Figure 33. Conversion Gain vs. RF Frequency at Various Temperatures, LO = 13 dBm

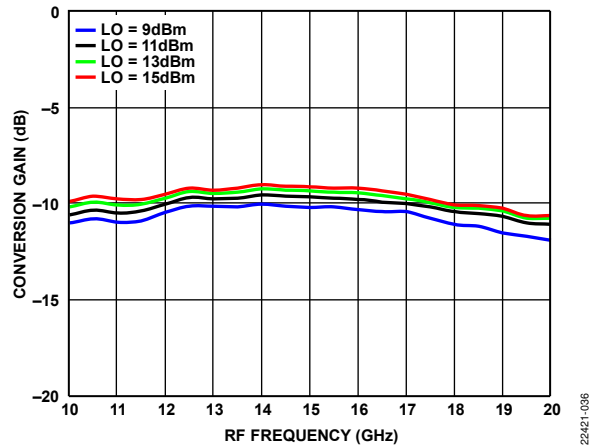

Figure 36. Conversion Gain vs. RF Frequency at Various LO Power Levels, TA = 25°C

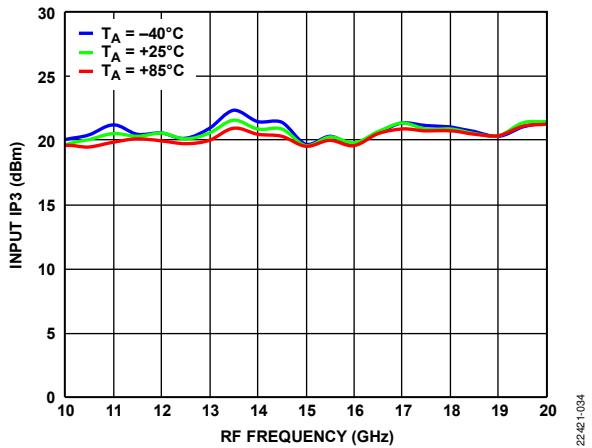

Figure 34. Input IP3 vs. RF Frequency at Various Temperatures, LO = 13 dBm

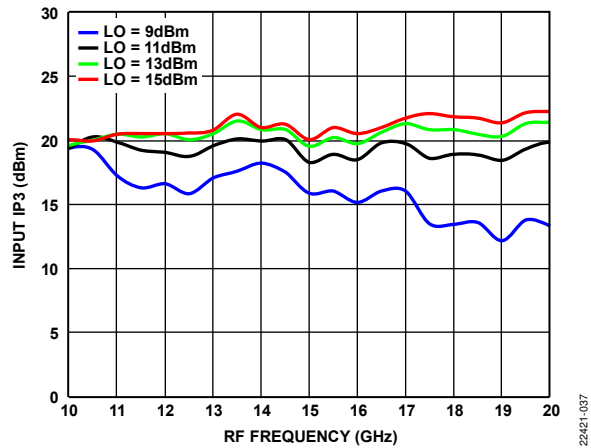

Figure 37. Input IP3 vs. RF Frequency at Various LO Power Levels, TA = 25°C

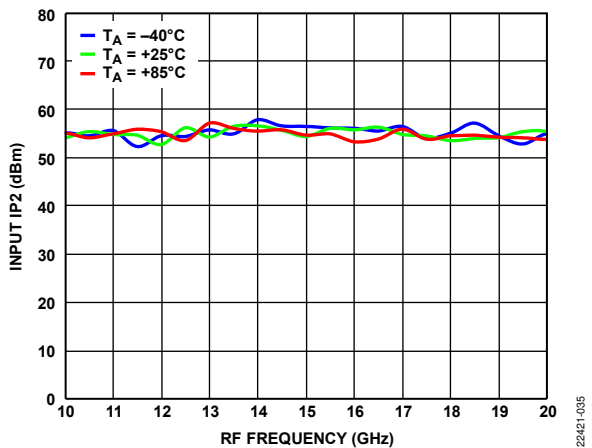

Figure 35. Input IP2 vs. RF Frequency at Various LO Power Levels, LO = 13 dBm

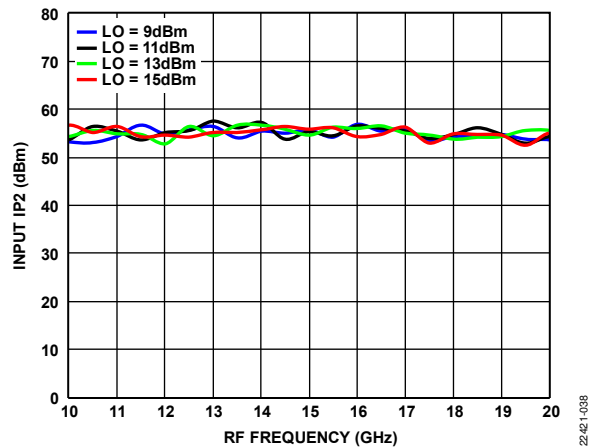

Figure 38. Input IP2 vs. RF Frequency at Various LO Power Levels, TA = 25°C

UPCONVERTER PERFORMANCE, IF = 100 MHz

Upper Sideband (Low-Side LO)

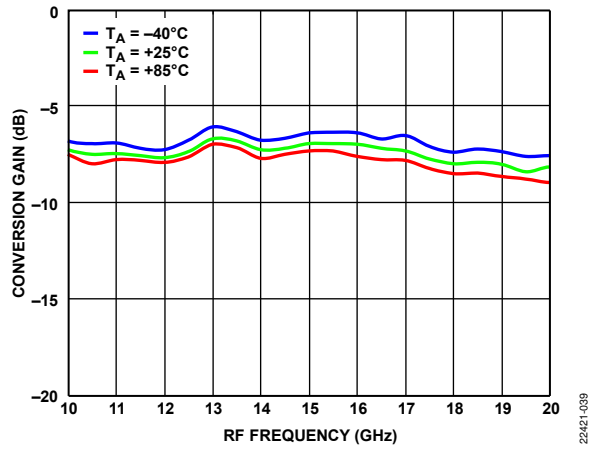

Figure 39. Conversion Gain vs. RF Frequency at Various Temperatures, LO = 13 dBm

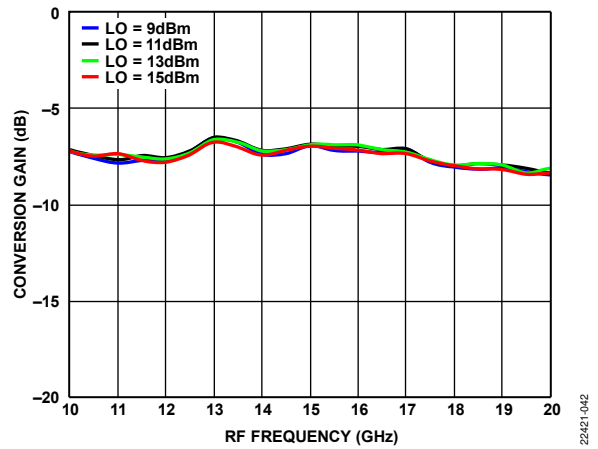

Figure 42. Conversion Gain vs. RF Frequency at Various LO Power Levels, TA = 25°C

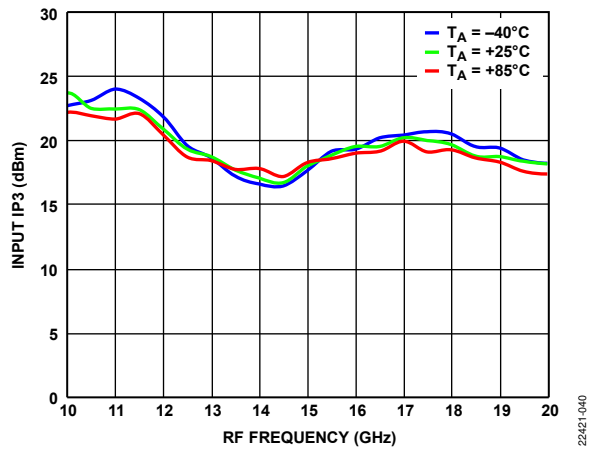

Figure 40. Input IP3 vs. RF Frequency at Various Temperatures, LO = 13 dBm

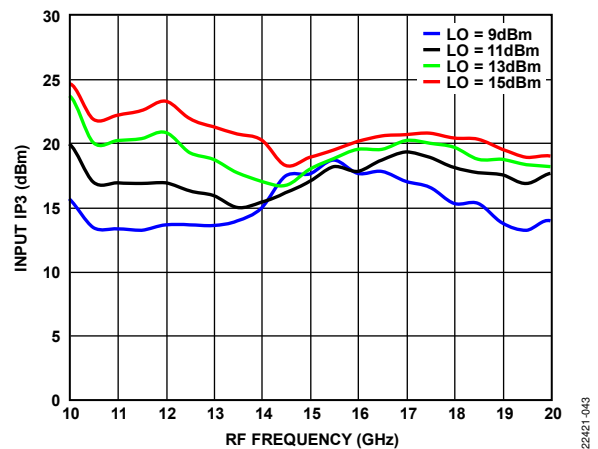

Figure 43. Input IP3 vs. RF Frequency at Various LO Power Levels, TA = 25°C

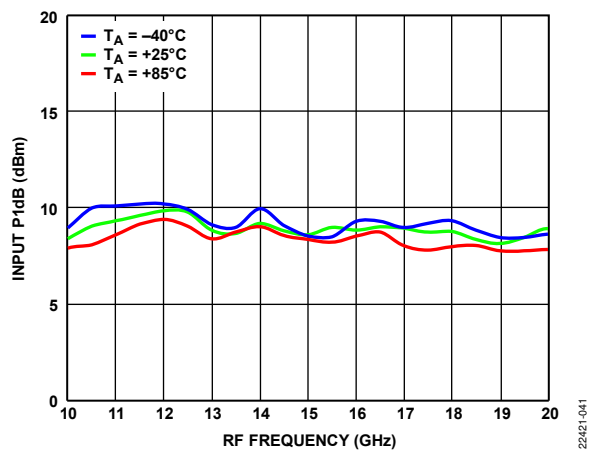

Figure 41. Input P1dB vs. RF Frequency at Various Temperatures, LO = 13 dBm

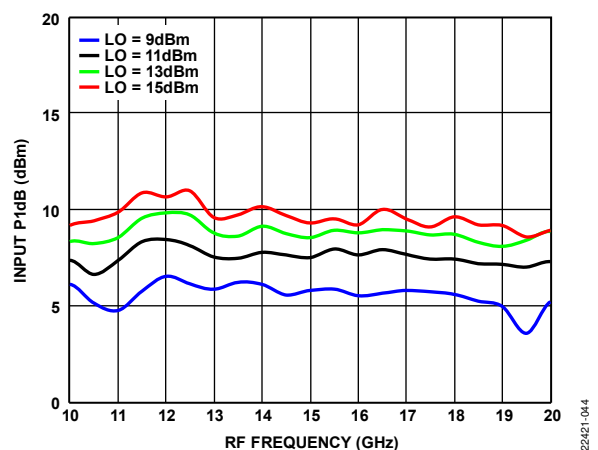

Figure 44. Input P1dB vs. RF Frequency at Various LO Power Levels, TA = 25°C

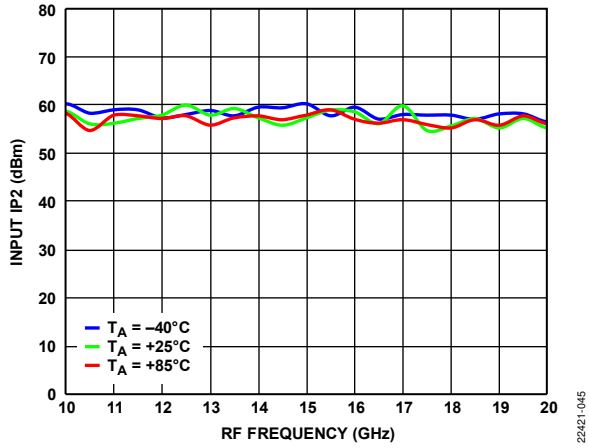

Figure 45. Input IP2 vs. RF Frequency at Various Temperatures, LO = 13 dBm

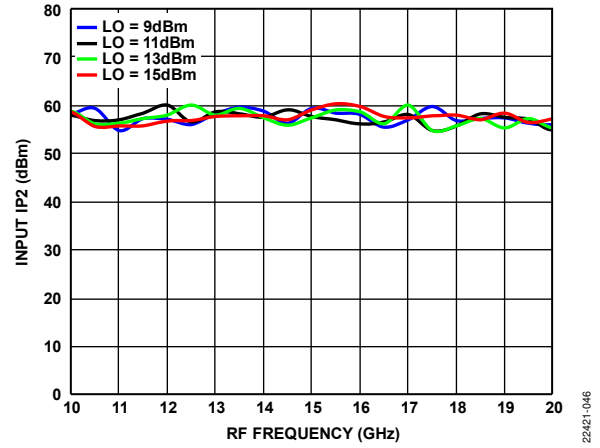

Figure 46. Input IP2 vs. RF Frequency at Various LO Power Levels, TA = 25°C

22421-045

22421-046

Lower Sideband (High-Side LO)

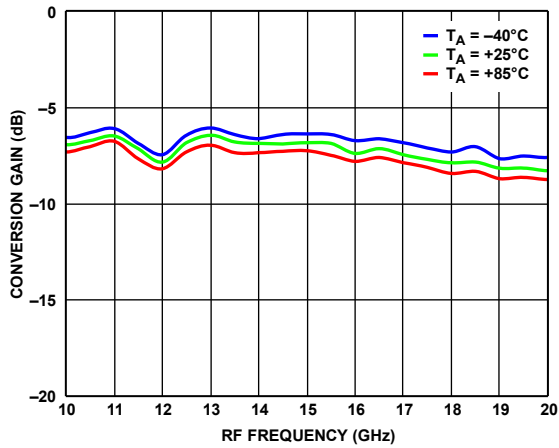

Figure 47. Conversion Gain vs. RF Frequency at Various Temperatures, LO = 13 dBm

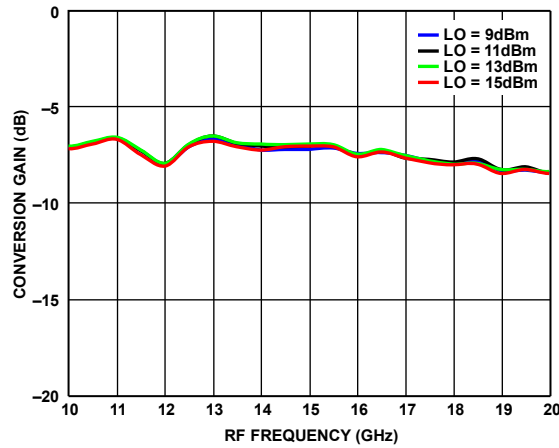

Figure 50. Conversion Gain vs. RF Frequency at Various LO Power Levels, $T_A = 25^\circ\text{C}$

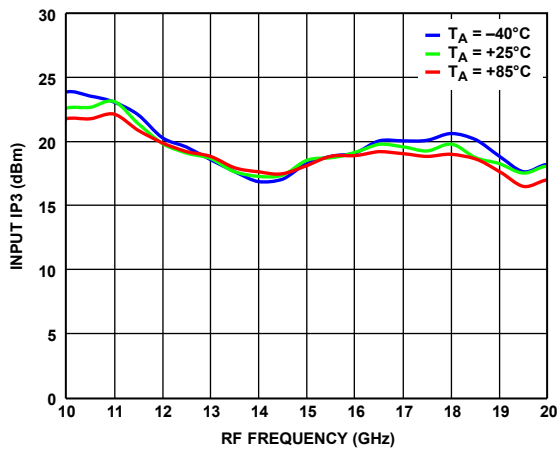

Figure 48. Input IP3 vs. RF Frequency at Various Temperatures, LO = 13 dBm

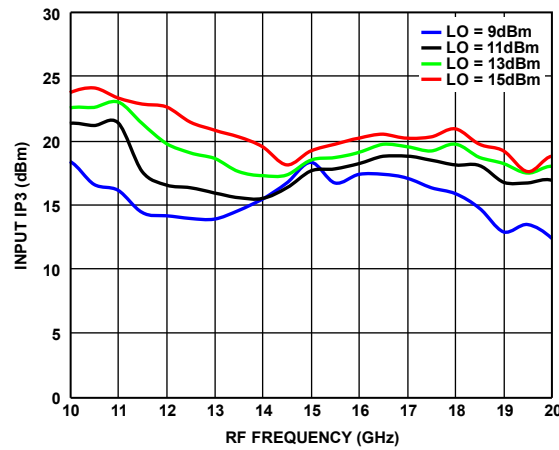

Figure 51. Input IP3 vs. RF Frequency at Various LO Power Levels, $T_A = 25^\circ\text{C}$

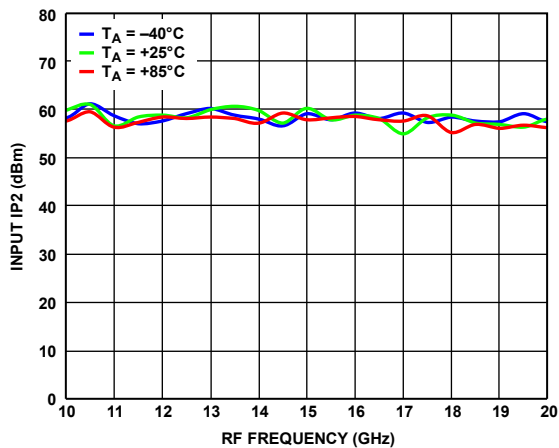

Figure 49. Input IP2 vs. RF Frequency at Various Temperatures, LO = 13 dBm

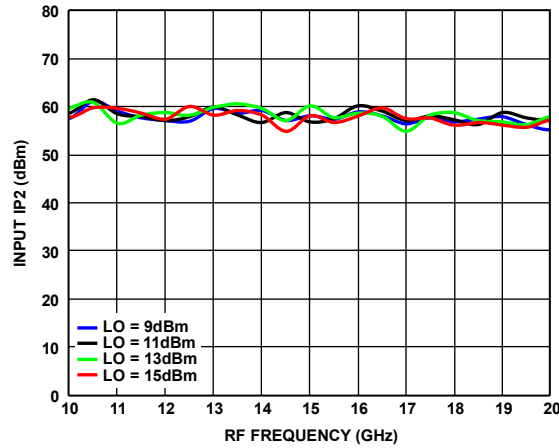

Figure 52. Input IP2 vs. RF Frequency at Various LO Power Levels, $T_A = 25^\circ\text{C}$

UPCONVERTER PERFORMANCE, IF = 3000 MHz
Upper Sideband (Low-Side LO)

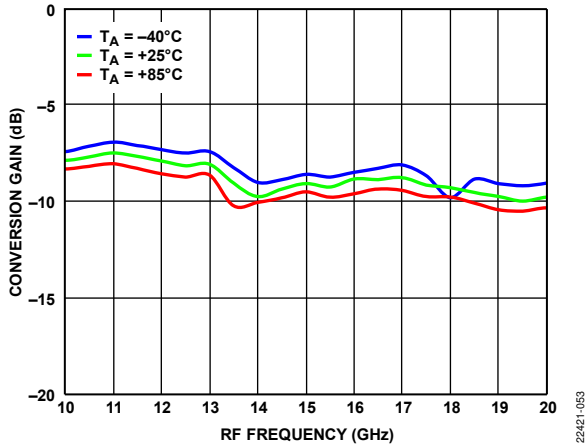

Figure 53. Conversion Gain vs. RF Frequency at Various Temperatures, LO = 13 dBm

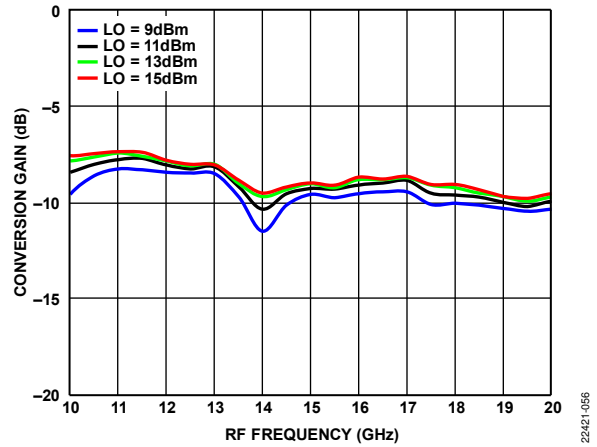

Figure 56. Conversion Gain vs. RF Frequency at Various LO Power Levels, TA = 25°C

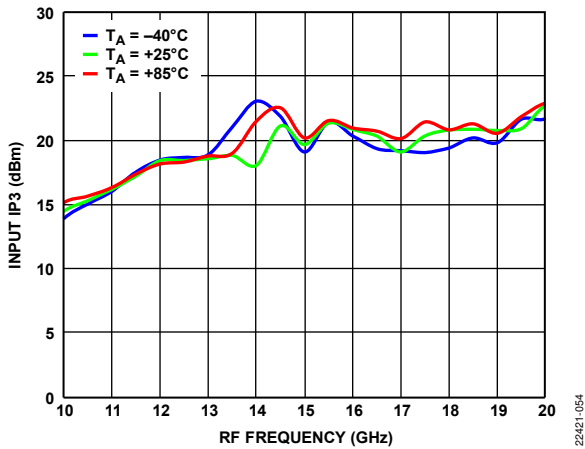

Figure 54. Input IP3 vs. RF Frequency at Various Temperatures, LO = 13 dBm

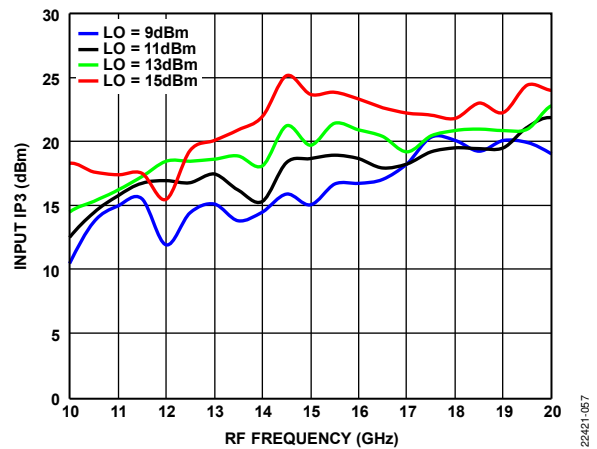

Figure 57. Input IP3 vs. RF Frequency at Various LO Power Levels, TA = 25°C

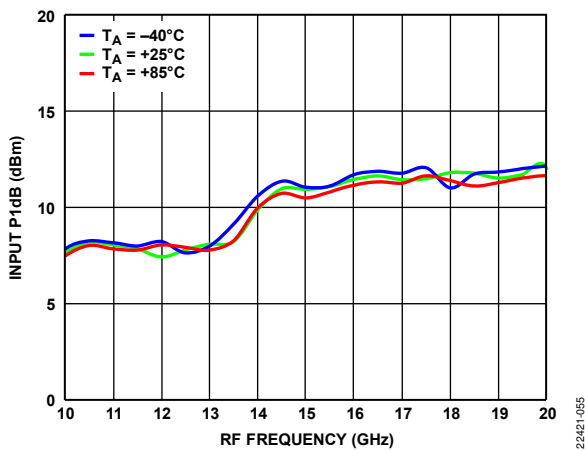

Figure 55. Input P1dB vs. RF Frequency at Various Temperatures, LO = 13 dBm

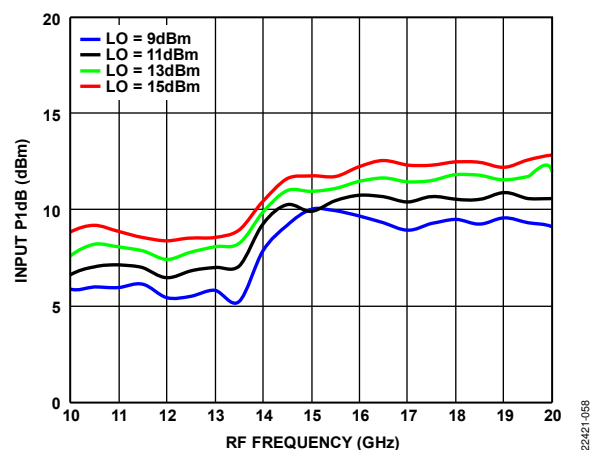

Figure 58. Input P1dB vs. RF Frequency at Various LO Power Levels, TA = 25°C

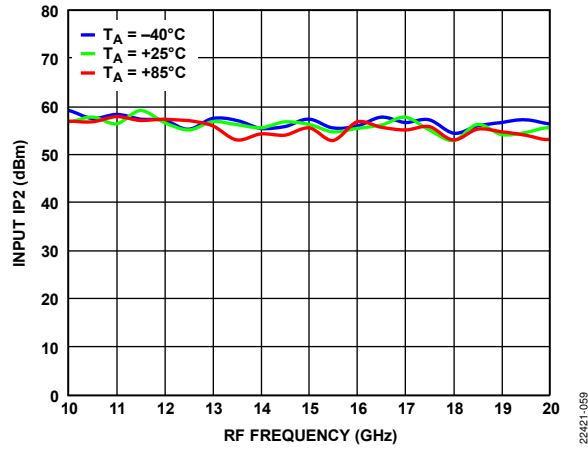

Figure 59. Input IP2 vs. RF Frequency at Various Temperatures, LO = 13 dBm

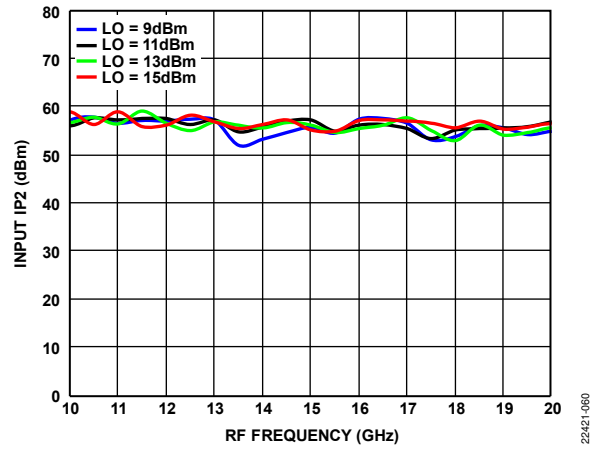

Figure 60. Input IP2 vs. RF Frequency at Various LO Power Levels, $T_A = 25^\circ\text{C}$

Lower Sideband (High-Side LO)

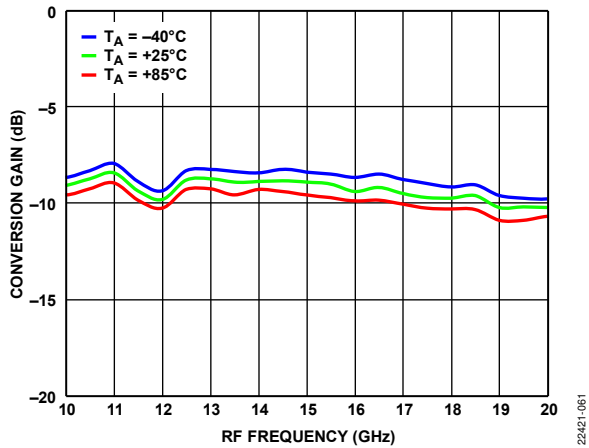

Figure 61. Conversion Gain vs. RF Frequency at Various Temperatures, LO = 13 dBm

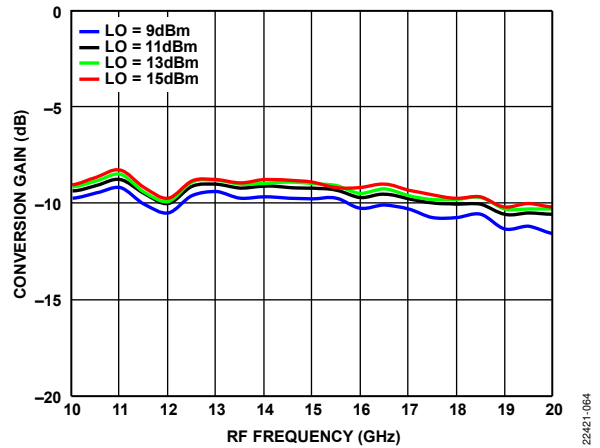

Figure 64. Conversion Gain vs. RF Frequency at Various LO Power Levels, TA = 25°C

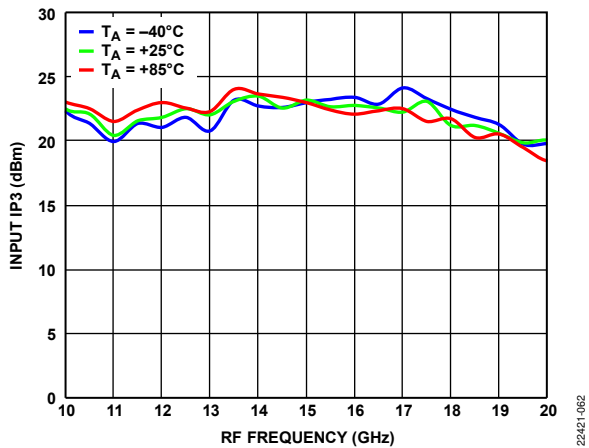

Figure 62. Input IP3 vs. RF Frequency at Various Temperatures, LO = 13 dBm

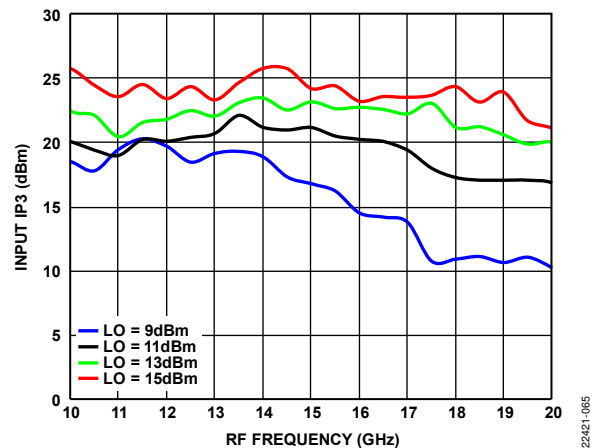

Figure 65. Input IP3 vs. RF Frequency at Various LO Power Levels, TA = 25°C

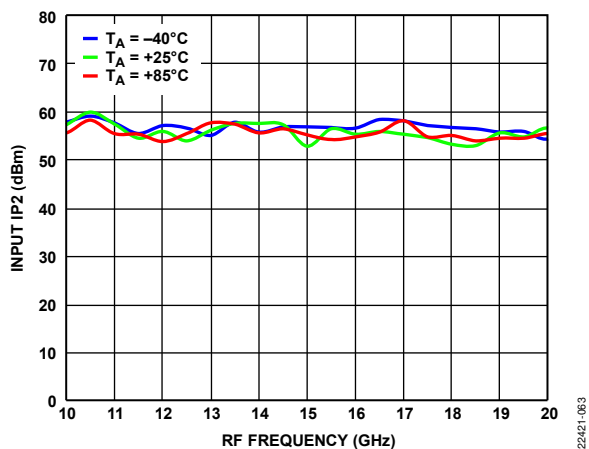

Figure 63. Input IP2 vs. RF Frequency at Various Temperatures, LO = 13 dBm

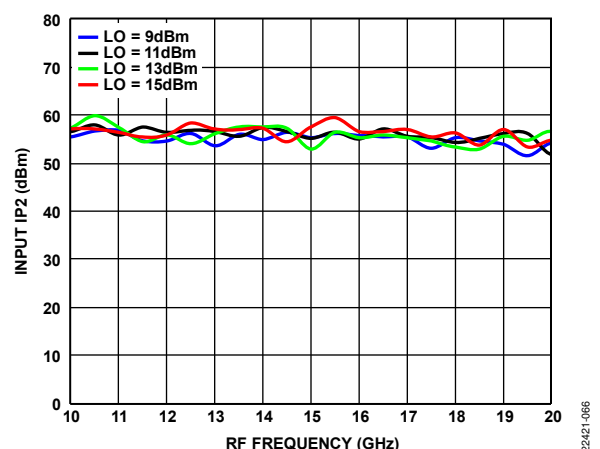

Figure 66. Input IP2 vs. RF Frequency at Various LO Power Levels, TA = 25°C

ISOLATION AND RETURN LOSS

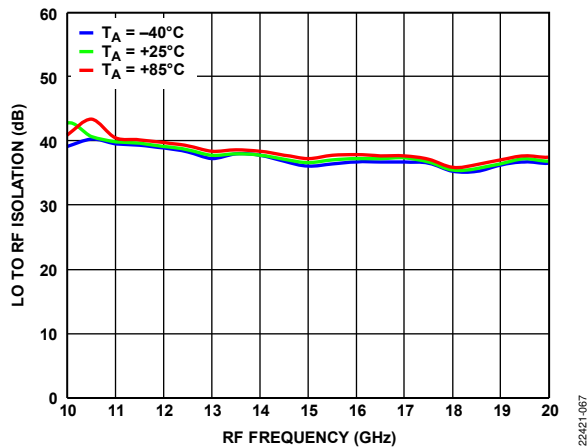

Figure 67. LO to RF Isolation vs. RF Frequency at Various Temperatures, LO = 13 dBm

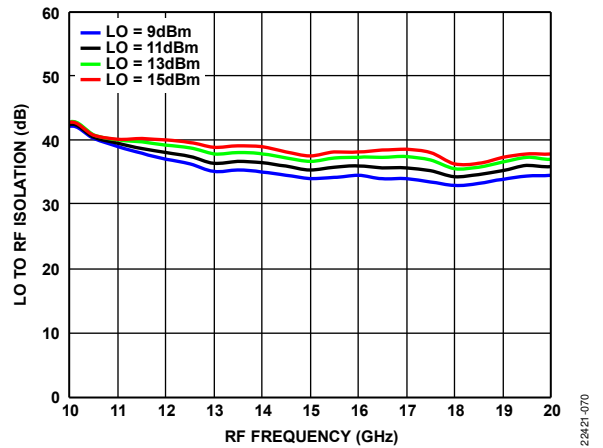

Figure 70. LO to RF Isolation vs. RF Frequency at Various LO Power Levels, TA = 25°C

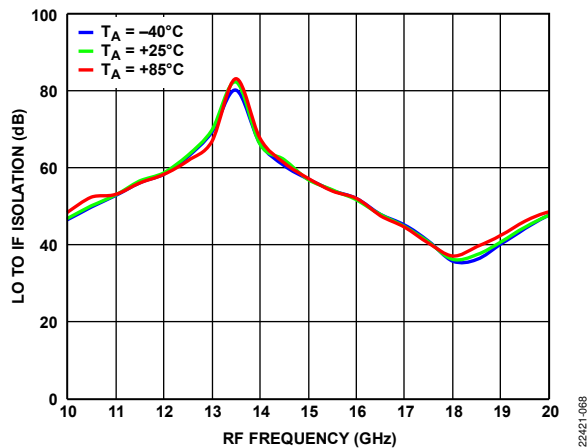

Figure 68. LO to IF Isolation vs. RF Frequency at Various Temperatures, LO = 13 dBm

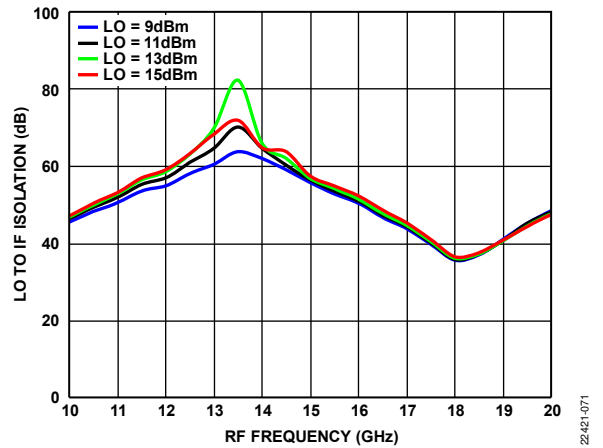

Figure 71. LO to IF Isolation vs. RF Frequency at Various LO Power Levels, TA = 25°C

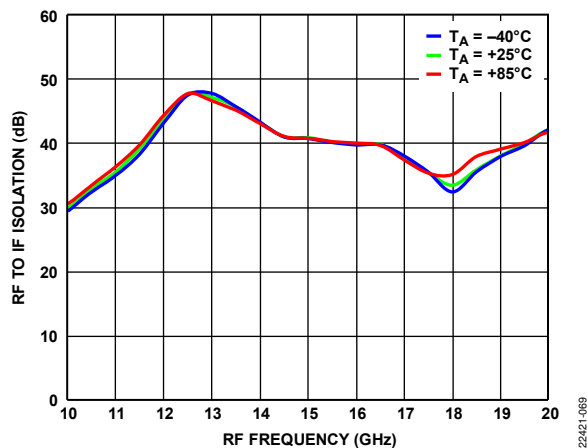

Figure 69. RF to IF Isolation vs. RF Frequency at Various Temperatures, LO = 13 dBm

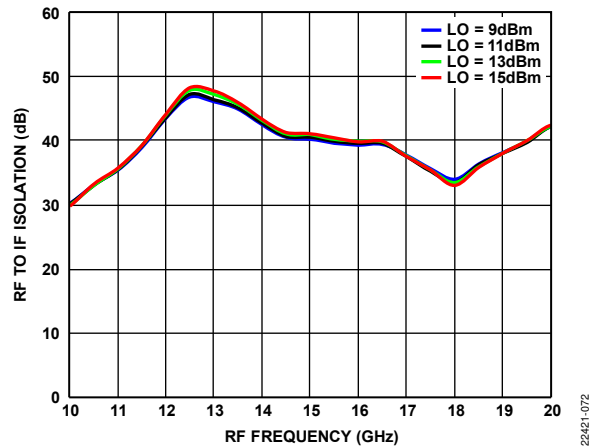

Figure 72. RF to IF Isolation vs. RF Frequency at Various LO Power Levels, TA = 25°C

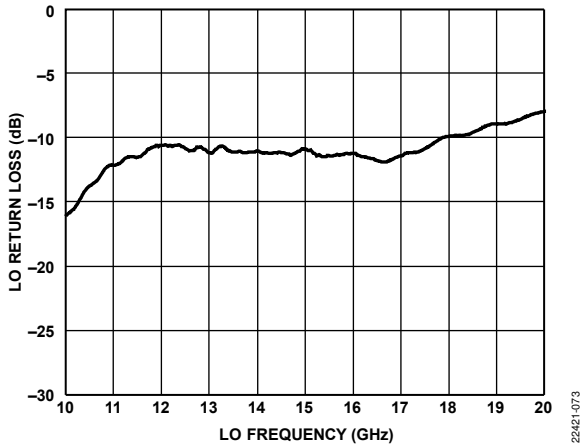

Figure 73. LO Return Loss vs. LO Frequency at LO = 13 dBm, $T_A = 25^\circ\text{C}$

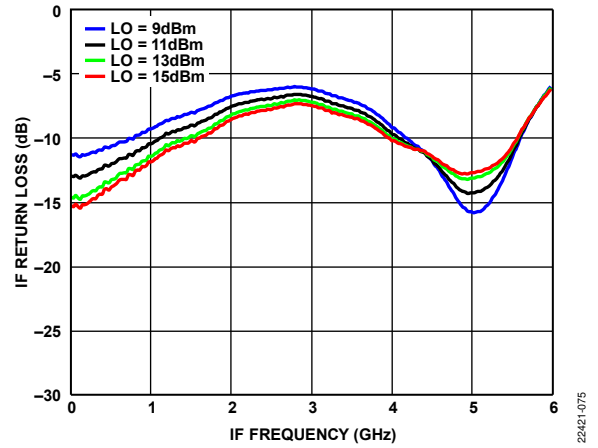

Figure 75. IF Return Loss vs. IF Frequency at Various LO Power Levels, $T_A = 25^\circ\text{C}$, LO = 15 GHz

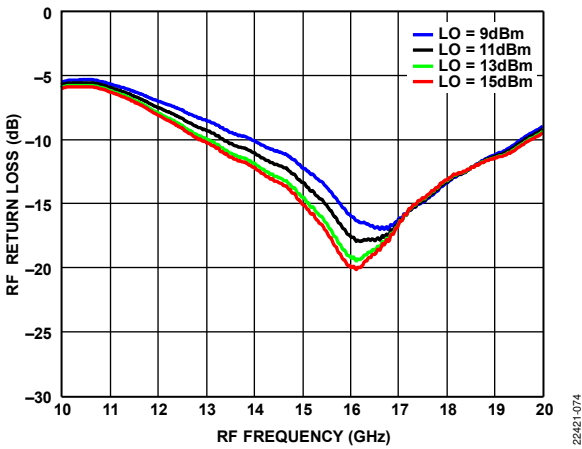

Figure 74. RF Return Loss vs. RF Frequency at Various LO Power Levels, $T_A = 25^\circ\text{C}$, LO = 15 GHz

22421-073

22421-075

22421-074

IF BANDWIDTH—DOWNCONVERTER

Upper Sideband, LO Frequency = 12 GHz

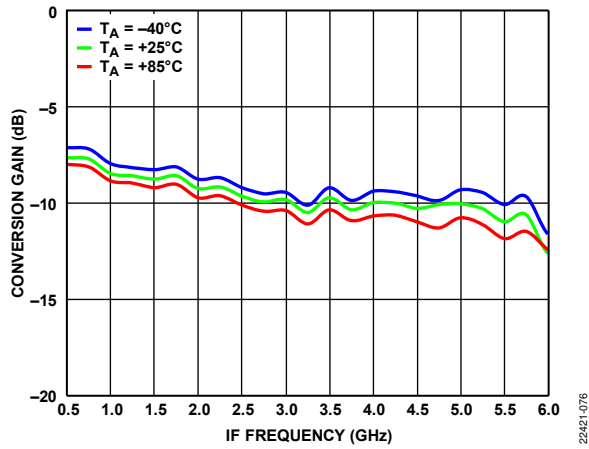

Figure 76. Conversion Gain vs. IF Frequency at Various Temperatures, LO = 13 dBm

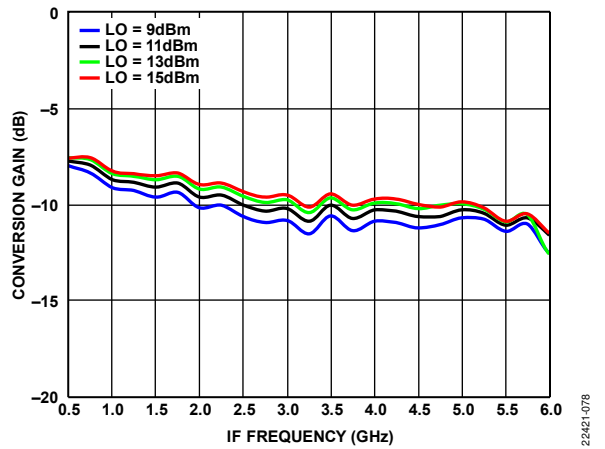

Figure 78. Conversion Gain vs. IF Frequency at Various LO Power Levels, $T_A = 25^\circ\text{C}$

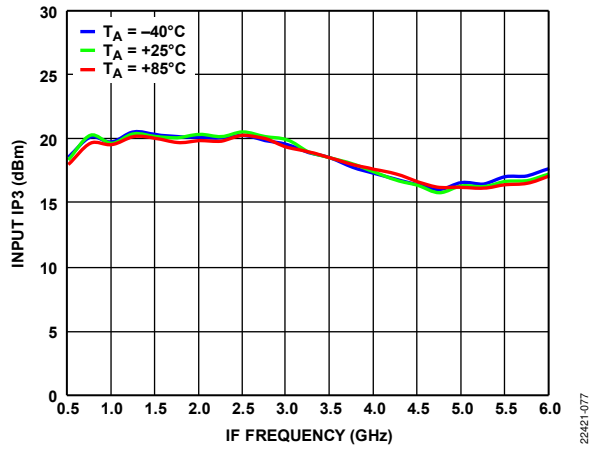

Figure 77. Input IP3 vs. IF Frequency at Various Temperatures, LO = 13 dBm

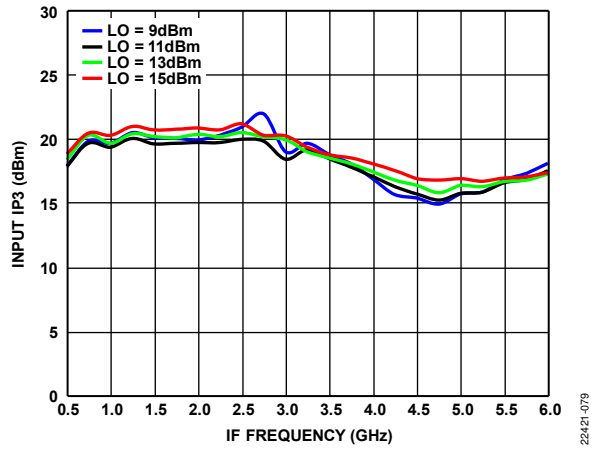

Figure 79. Input IP3 vs. IF Frequency at Various LO Power Levels, $T_A = 25^\circ\text{C}$

Lower Sideband, LO Frequency = 19 GHz

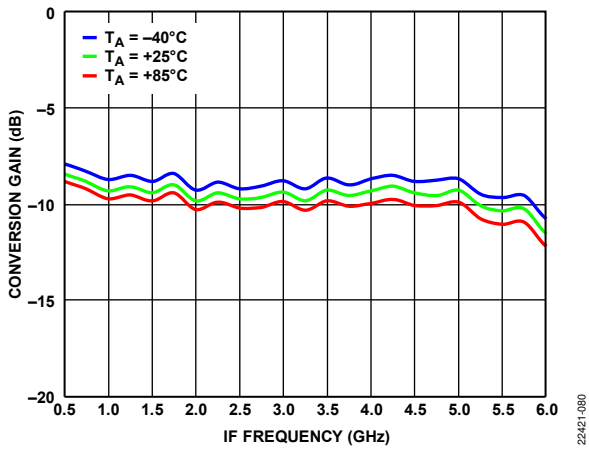

Figure 80. Conversion Gain vs. IF Frequency at Various Temperatures, LO = 13 dBm

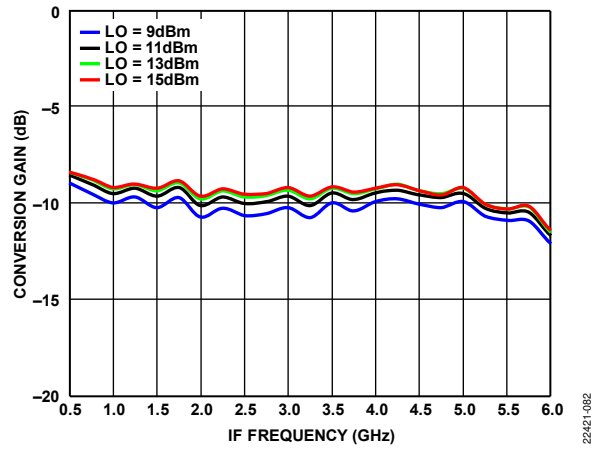

Figure 82. Conversion Gain vs. IF Frequency at Various LO Power Levels, TA = 25°C

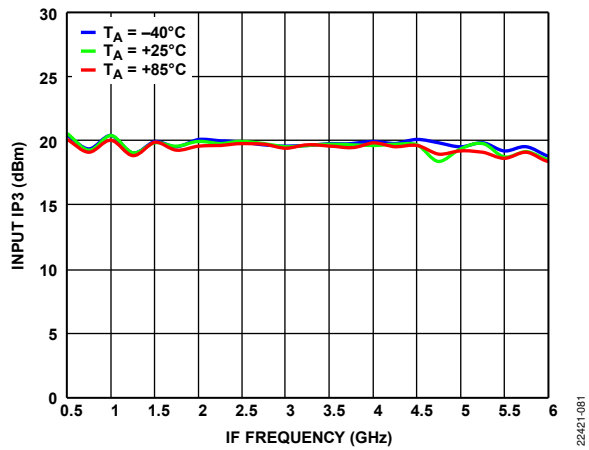

Figure 81. Input IP3 vs. IF Frequency at Various Temperatures, LO = 13 dBm

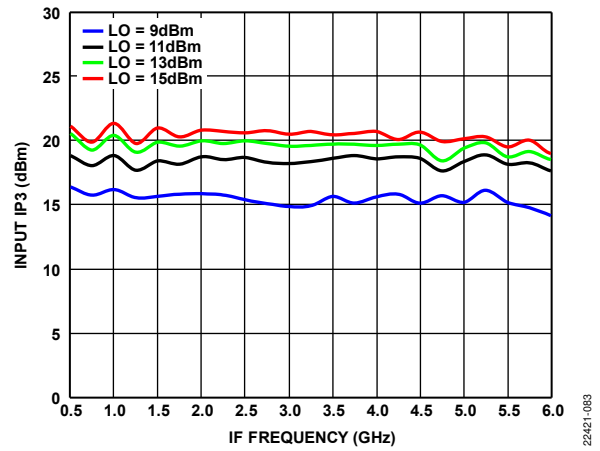

Figure 83. Input IP3 vs. IF Frequency at Various LO Power Levels, TA = 25°C

SPURIOUS AND HARMONICS PERFORMANCE

Mixer spurious products are measured in dBc from the IF output power level. N/A means not applicable.

LO Harmonics

LO = 13 dBm, all values in dBc are below the input LO level and are measured at the RF port.

Table 4. LO Harmonics at RF

LO Frequency (GHz)	N × LO Spur at RF Port			
	1	2	3	4
12	34	36	68	48
13	35	44	53	N/A
15	32	43	48	N/A
16	32	50	47	N/A
18	30	55	N/A	N/A
19	32	45	N/A	N/A
21	33	41	N/A	N/A

LO = 13 dBm, all values in dBc are below the input LO level and are measured at the IF port.

Table 5. LO Harmonics at IF

LO Frequency (GHz)	N × LO Spur at IF Port			
	1	2	3	4
12	55	64	57	76
13	58	61	55	N/A
15	50	63	51	N/A
16	46	67	50	N/A
18	31	62	N/A	N/A
19	37	58	N/A	N/A
21	45	56	N/A	N/A

M × N Spurious Outputs

Downconverter, Upper Sideband

Spur values are (M × RF) – (N × LO).

RF = 15.1 GHz at –10 dBm, and LO = 15 GHz at +13 dBm.

		N × LO					
		0	1	2	3	4	5
M × RF	0	N/A	24	36	23	N/A	N/A
	1	33	0	54	57	52	N/A
	2	72	81	60	81	73	62
	3	60	73	83	72	83	71
	4	N/A	62	71	81	>90	78
	5	N/A	N/A	61	74	81	>90

Upconverter, Upper Sideband

Spur values are (M × IF) + (N × LO).

IF = 100 MHz at –10 dBm, and LO = 15 GHz at +13 dBm.

		N × LO			
		0	1	2	3
M × IF	–5	>90	89	77	67
	–4	>90	83	77	68
	–3	79	52	67	53
	–2	87	67	65	50
	–1	33	0	30	12
	0	N/A	14	20	24
	+1	33	0	30	11
	+2	85	55	66	48
	+3	78	52	67	50
	+4	>90	86	79	64
	+5	>90	87	76	63

THEORY OF OPERATION

The HMC554ACHIPS is a general-purpose, double balanced mixer that can be used as an upconverter or a downconverter from 10 GHz to 20 GHz.

When used as a downconverter, the HMC554ACHIPS downconverts RF between 10 GHz and 20 GHz to IF between dc and 6 GHz.

When used as an upconverter, the mixer upconverts IF between dc and 6 GHz to RF between 10 GHz and 20 GHz.

APPLICATIONS INFORMATION

TYPICAL APPLICATION CIRCUIT

Figure 84 shows the typical application circuit for the HMC554ACHIPS. The HMC554ACHIPS is a passive device that does not require any external components. The IF pad is internally dc-coupled, and the RF and LO pads are internally ac-coupled. When IF operation to dc is not required, it is recommended to use an external series capacitor of a value chosen to pass the necessary IF frequency range. When IF operation to dc is required, do not exceed the IF source and sink current rating specified in the Absolute Maximum Ratings section.

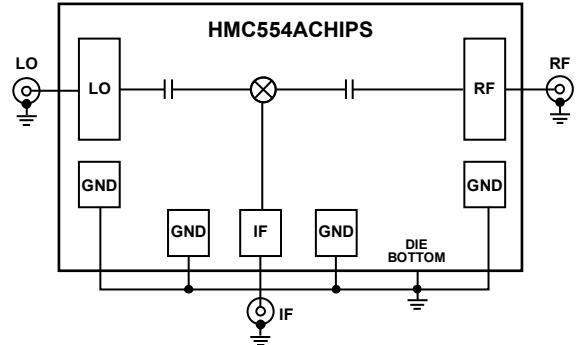

Figure 84. Typical Application Circuit

22421-090

MOUNTING AND BONDING TECHNIQUES

Attach the die directly to the ground plane eutectically or with conductive epoxy. To bring RF to and from the chip, 50 Ω microstrip transmission lines on 0.127 mm (0.005") thick, alumina thin film substrates are recommended (see Figure 85). If using 0.254 mm (0.010") thick, alumina thin film substrates, raise the die 0.150 mm (0.006") so that the surface of the die is coplanar with the surface of the substrate. A way to accomplish this is to attach the 0.102 mm (0.004") thick die to a 0.150 mm (0.006") thick molybdenum heat spreader (moly tab) which is then attached to the ground plane (see Figure 86). Place microstrip substrates as close to the die as possible to minimize bond wire length. Typical die to substrate spacing is 0.076 mm (0.003").

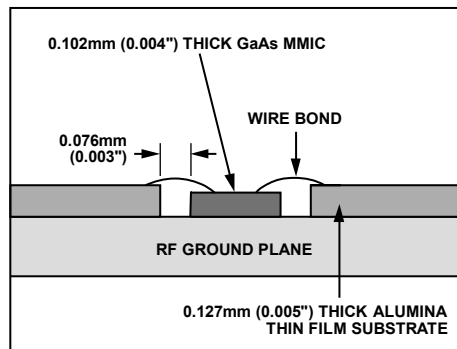

Figure 85. Bonding RF Pads to 0.127 mm Substrate

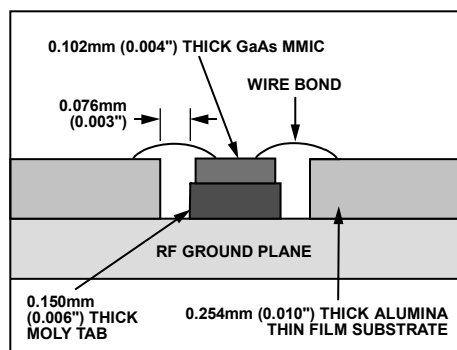

Figure 86. Bonding RF Pads to 0.254 mm Substrate

HANDLING PRECAUTIONS

Follow the precautions in the Storage section, the Cleanliness section, the Static Sensitivity section, the Transients section, and the General Handling section to avoid permanent damage to the HMC554ACHIPS.

Storage

All bare dice are placed in either waffle-based or gel-based, ESD protective containers and then sealed in an ESD protective bag for shipment. Once the sealed ESD protective bag is open, store all dies in a dry nitrogen environment.

Cleanliness

Handle the chips in a clean environment. Do not attempt to clean the chips using liquid cleaning systems.

Static Sensitivity

Follow ESD precautions to protect against ESD strikes.

Transients

Suppress instrument and bias supply transients while bias is applied. Use shielded signal and bias cables to minimize inductive pickup.

General Handling

Handle the chip along the edges with a vacuum collet or with a sharp pair of bent tweezers. The surface of the chip has fragile air bridges and must not be touched with a vacuum collet, tweezers, or fingers.

MOUNTING

The chip is back metallized and can be die mounted either with gold (Au)/tin (Sn) eutectic preforms or with electrically conductive epoxy. The mounting surface must be clean and flat.

Eutectic Die Attach

An 80/20 gold and tin preform is recommended with a work surface temperature of 255°C and a tool temperature of 265°C. When hot 90/10 nitrogen (N)/hydrogen (H) gas is applied, the tool tip temperature must be 290°C. Do not expose the chip to a temperature greater than 320°C for more than 20 seconds. No more than 3 seconds of scrubbing is required for attachment.

Epoxy Die Attach

Apply a minimum amount of epoxy to the mounting surface so that a thin epoxy fillet is observed around the perimeter of the chip when the chip is placed into position. Cure epoxy per the schedule of the manufacturer.

WIRE BONDING

Ball or wedge bond with 0.025 mm (0.00098") diameter, pure gold wire is recommended. Thermosonic wire bonding with a nominal stage temperature of 150°C, and either a ball bonding force of 40 grams to 50 grams or a wedge bonding force of 18 grams to 22 grams is recommended. Use the minimum level of ultrasonic energy to achieve reliable wire bonds. Wire bonds must start on the chip and terminate on the package or substrate. All bonds must be as short as possible at <0.31 mm (0.01220").

ASSEMBLY DIAGRAM

The assembly diagram of the HMC554ACHIPS is shown in Figure 87.

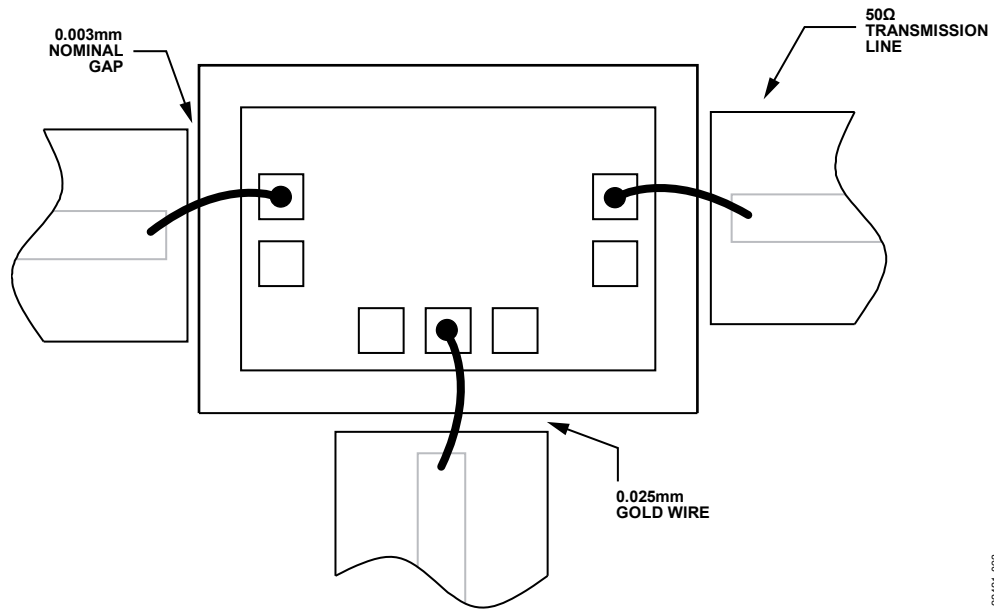
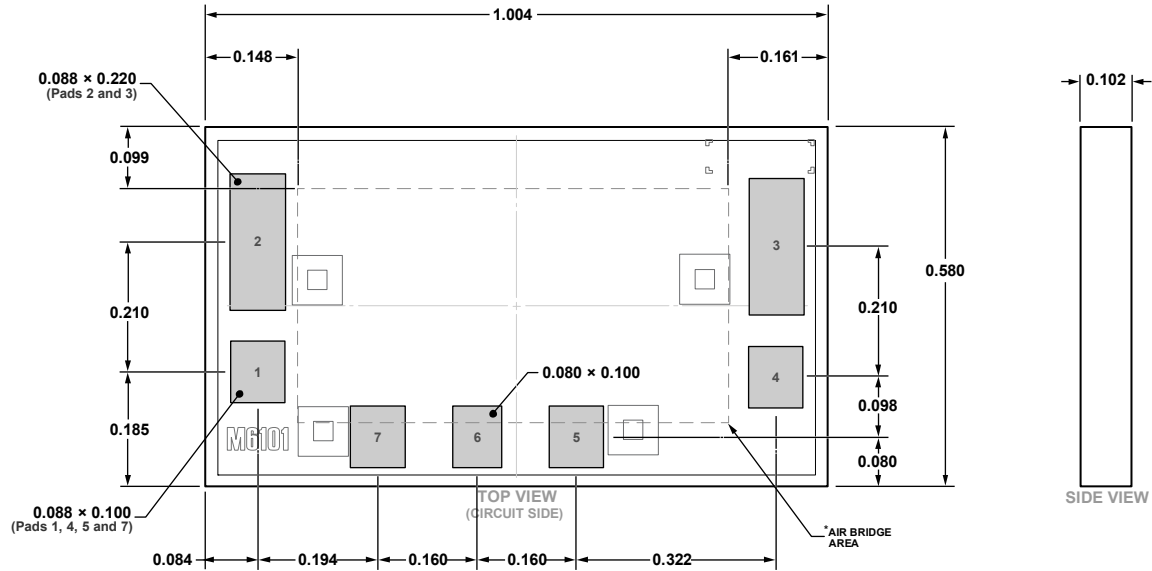

Figure 87. Evaluation PCB Top Layer

22421-083

OUTLINE DIMENSIONS



*This die utilizes fragile air bridges. Any pickup tools used must not contact this area.

Figure 88. 7-Pad Bare Die [CHIP]
(C-7-11)
Dimensions shown in millimeters

09-19-2019--A

ORDERING GUIDE

Model ¹	Temperature Range	Package Description	Package Option
HMC554A	-40°C to +85°C	7-Pad Bare Die [CHIP]	C-7-11
HMC554A-SX	-40°C to +85°C	7-Pad Bare Die [CHIP]	C-7-11

¹ The HMC554A and HMC554A-SX are RoHS compliant parts.