

PRODUCT NUMBER	ASSEMBLY TYPE	DIM "A"	DIM "B"	DIM "C"	DIM "D"	DIM "G" PITCH	MATING BUS-BAR THICKNESS DIM "H" ±0.10
10129416-001LF	OPEN SIDE WALL	2.56	9.4	30.0	32.3	23.0	2.00
10129416-002LF		3.56	10.4	31.0	33.3	24.0	3.00
10129416-003LF		4.56	11.4	32.0	34.3	25.0	4.00
10129416-004LF	CLOSED SIDE WALL	2.56	9.4	30.0	32.3	23.0	2.00
10129416-005LF		3.56	10.4	31.0	33.3	24.0	3.00
10129416-006LF		4.56	11.4	32.0	34.3	25.0	4.00

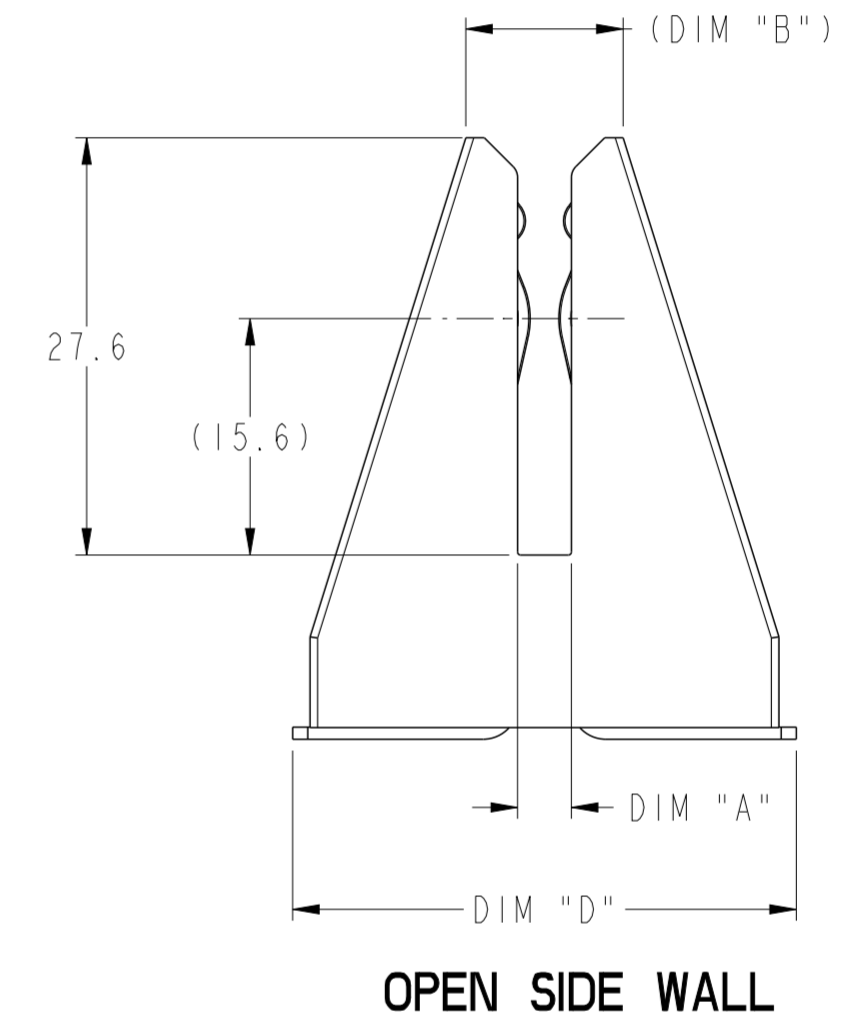

CLOSED SIDE WALL

OPEN SIDE WALL

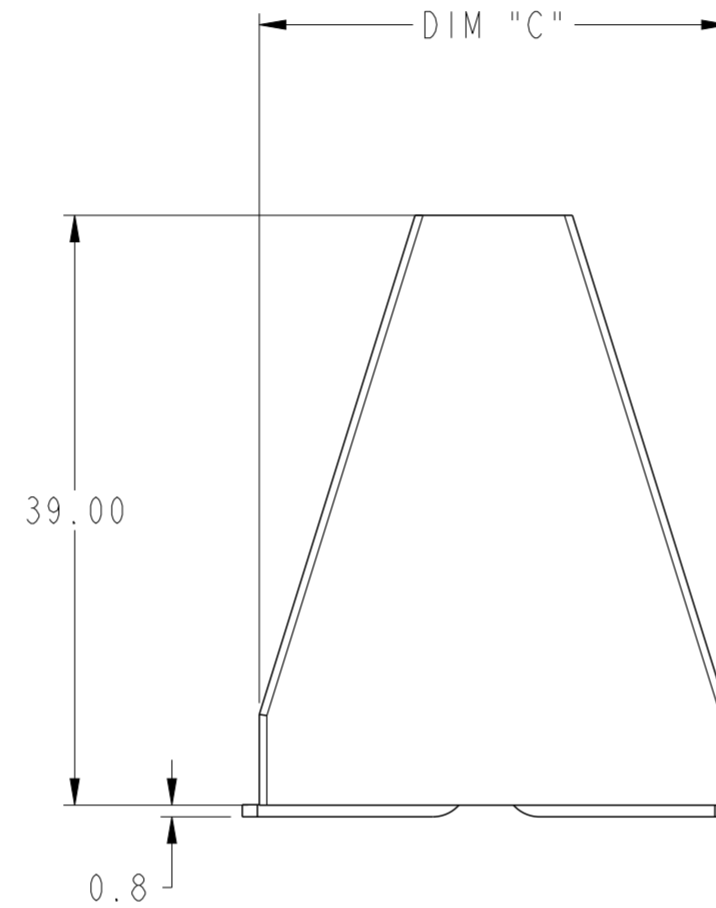
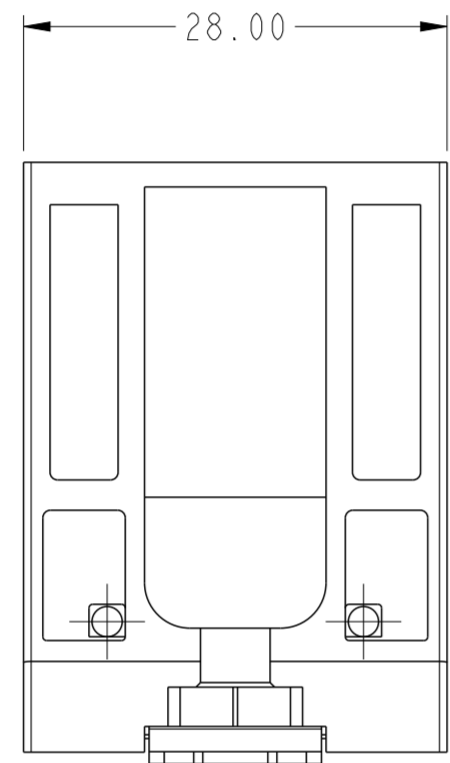
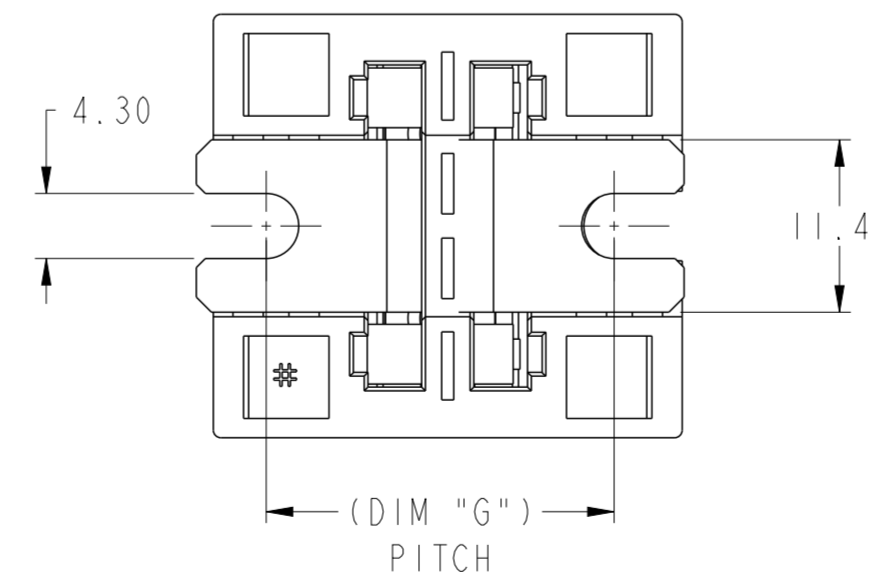

<p><b>CLOSED SIDE WALL</b></p> <p>SCALE 1:1</p>	<p><b>OPEN SIDE WALL</b></p> <p>SCALE 1:1</p>
---	---

spec ref	-	dr	Hung Ngo	2014/09/12	projection	mm	size	A2	scale	2:1			
tolerance std	ASME Y14.5M	eng	Terris Liu	2015/12/14	chr	-	ecn no	-	rel level	Preliminary			
surface	ASME Y14.5M	linear	0.X	±0.50	angular	0°	±2°	product family	BarKlip VERTICAL ASSEMBLY OPEN SLOT TYPE	cat. no.	10129416	rev	1
<p>PRELIMINARY DRAWING</p> <p>Product - Customer Drw sheet 1 of 2</p>													

Copyright FCI. FCI

S.NO	DESCRIPTION	QTY	REMARKS
1	Product	1	OPEN / CLOSED SIDE WALL
2	MATING BUS-BAR	1	PLATING RECOMMENDATION:3 um Silver over 2.54 um Nickel
3	M4 SCREW	2	
4	M4 WASHER	4	
5	M4 NUT	2	
6	MOUNTING BUS-BAR	1	PLATING RECOMMENDATION:3 um Silver over 2.54 um Nickel

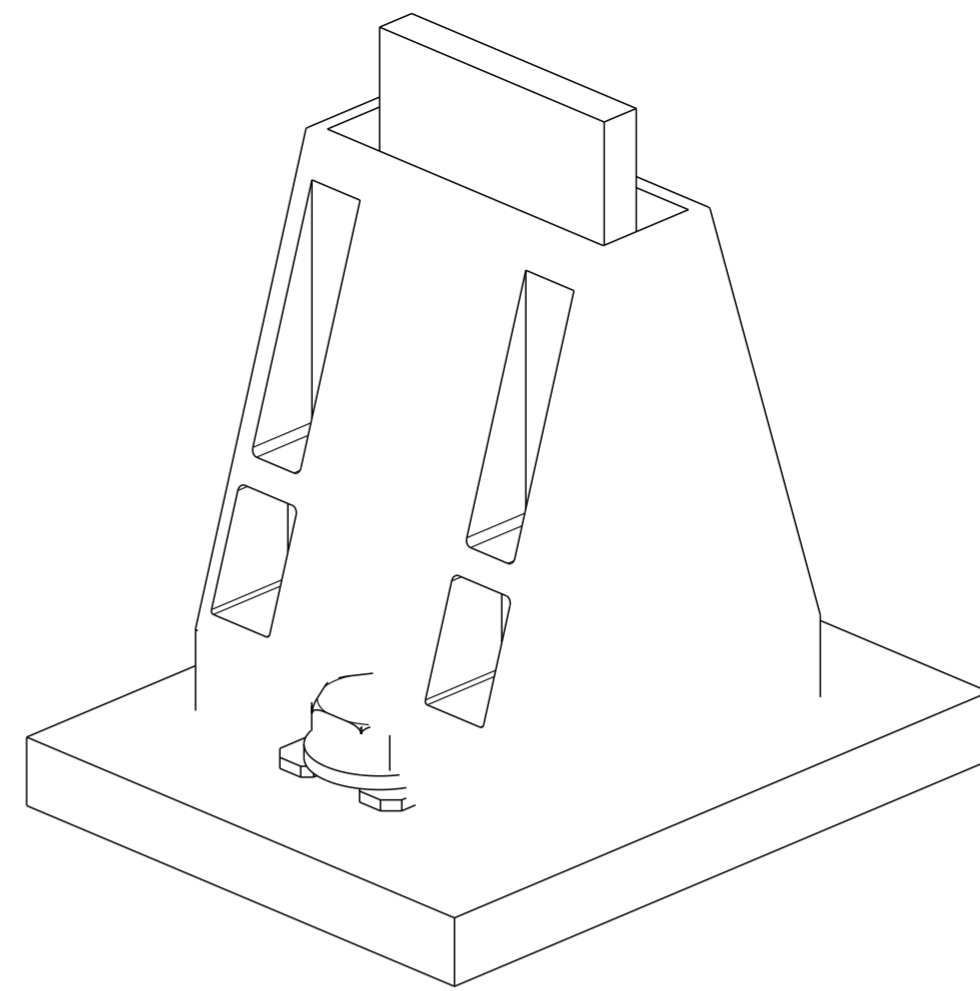

CLOSED SIDE WALL

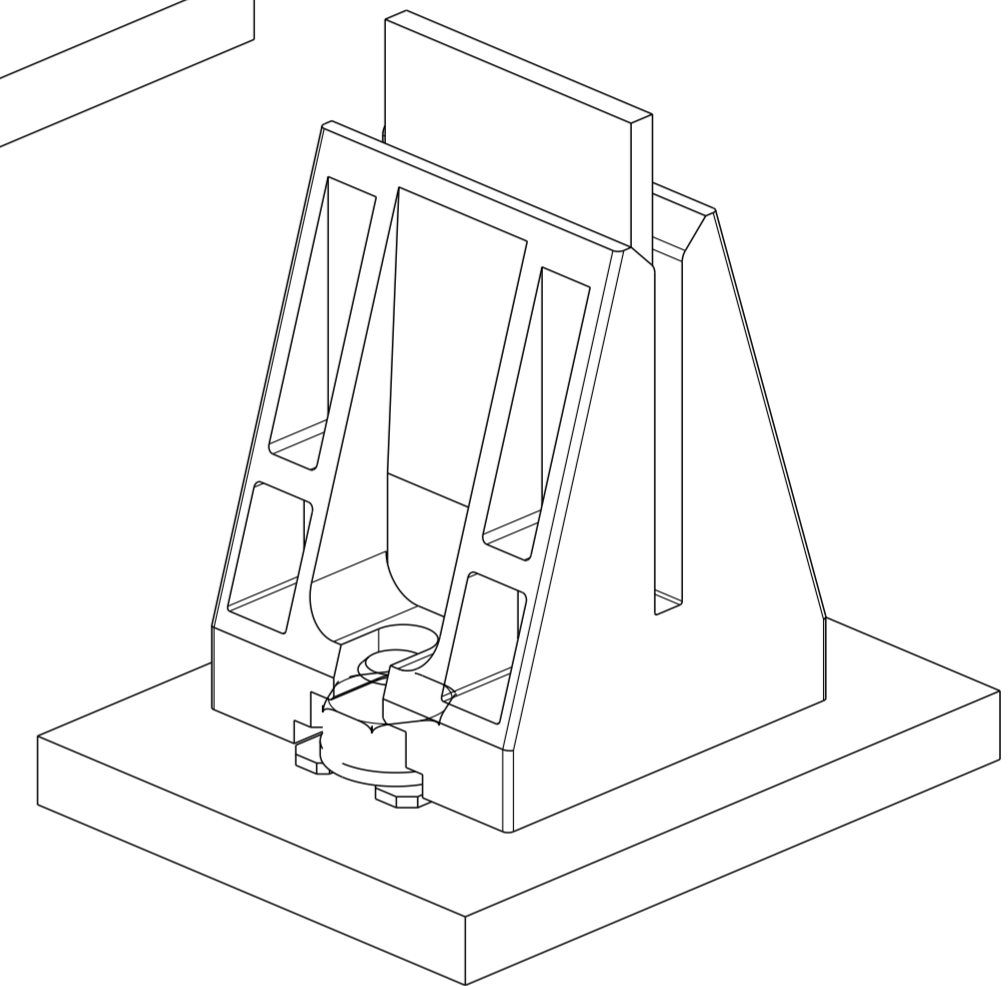

OPEN SIDE WALL

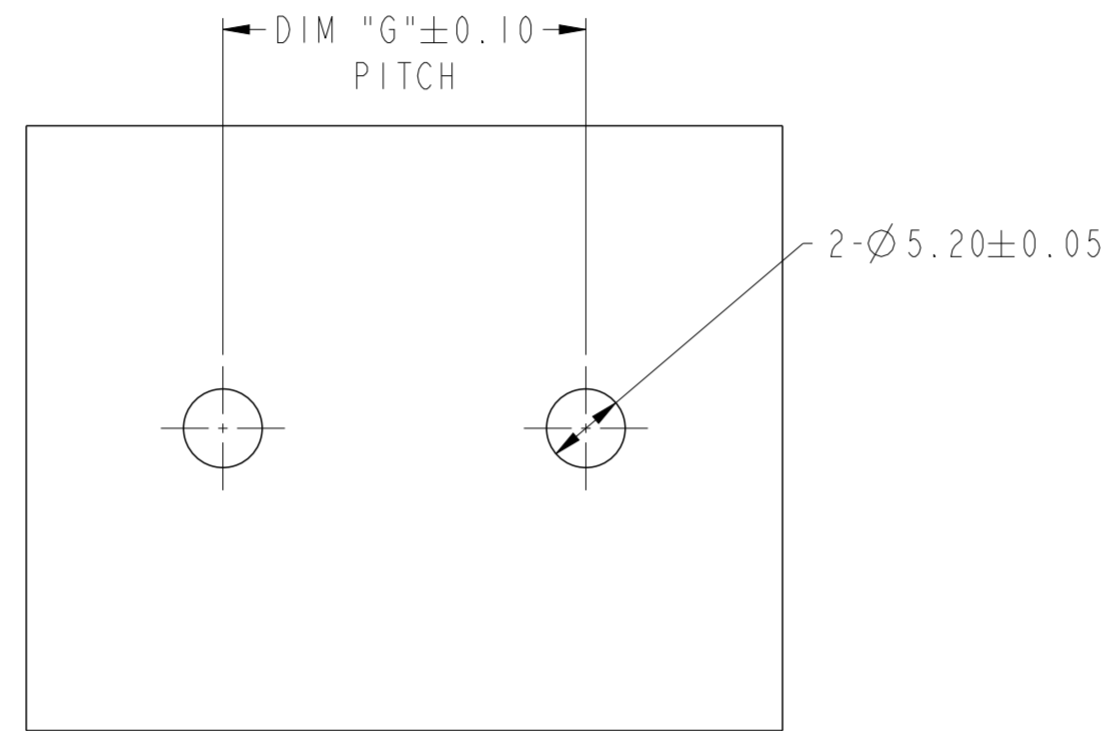

SCALE 2:1  
RECOMMENDED MOUNTING BUS-BAR  
THICKNESS 5.00 MAX.

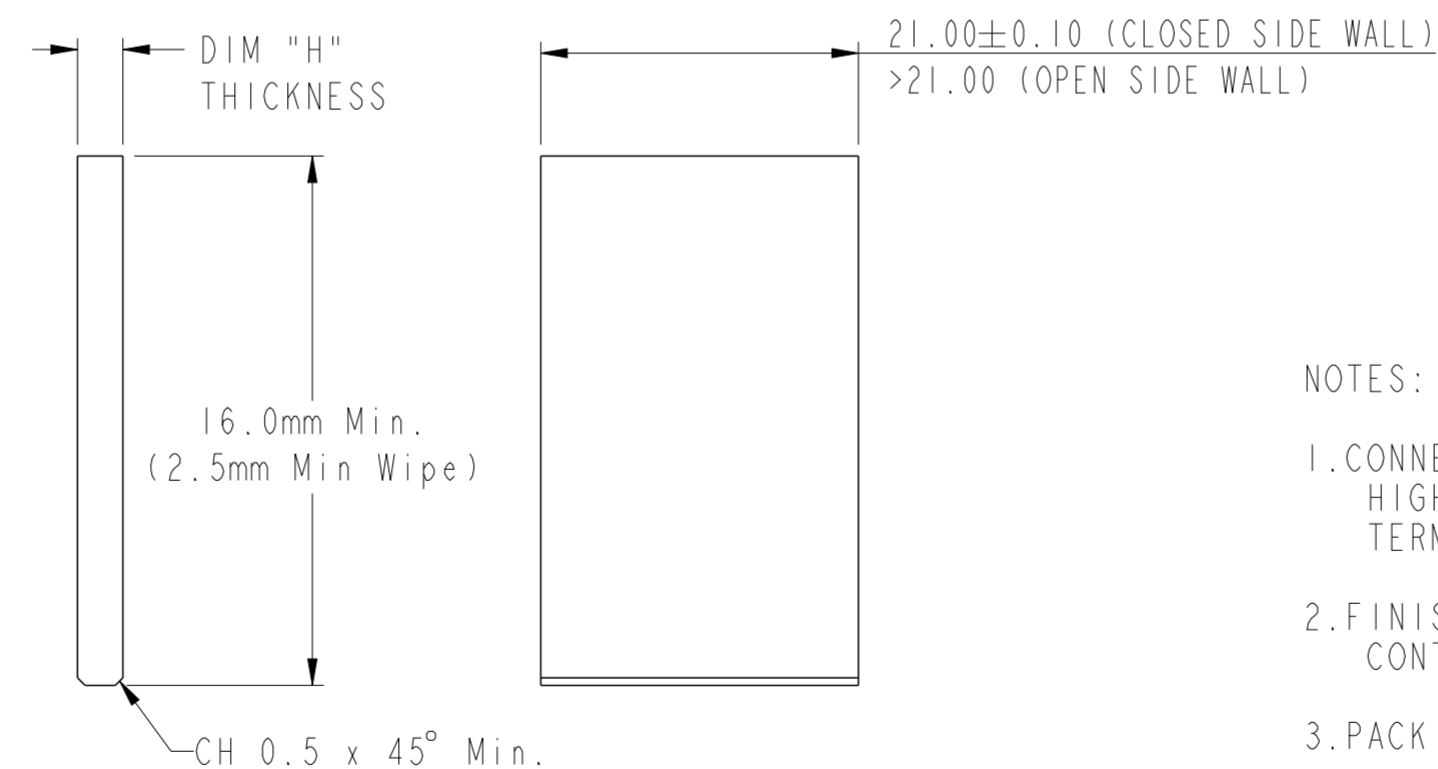

SCALE 2:1  
RECOMMENDED MATING BUS-BAR

NOTES:

- CONNECTOR HOUSING:  
HIGH TEMPERATURE THERMOPLASTIC GLASS FILLED, Black, UL 94V-0  
TERMINALS: COPPER ALLOY
- FINISHES:  
CONTACT AREA: PLATED AGT OVER NICKEL I
- PACKING SPECIFICATION: GS-14-2376
- PRODUCT SPECIFICATION: GS-12-1319
- PRODUCT APPLICATION: GS-20-0446

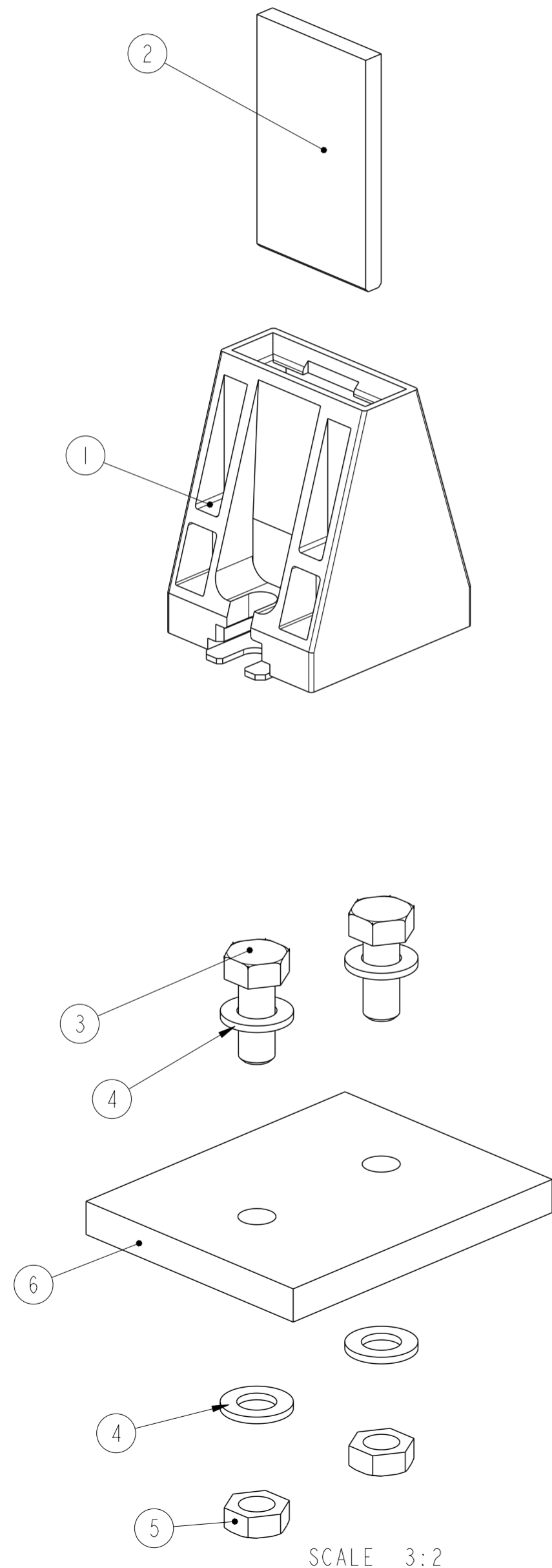

SCALE 3:2

spec ref -			dr Hung Ngo	2014/09/12	projection	mm	size A2	scale 2:1
tolerance std -			eng Terris Liu	2015/12/14			ecn no -	rel level Preliminary
ASME Y14.5M			chr -	-				
TOLERANCES UNLESS OTHERWISE SPECIFIED			appr -	-	product family -	title BarKlip VERTICAL ASSEMBLY		
surface ✓			www.fci.com			cat. no. -		
ASME Y14.5M			linear	0.X ±0.50	dwg no 10129416			rev 1
			0.XX ±0.30	Product - Customer Drw			sheet 2 of 2	
			0.XXX ±0.15					
			angular	0° ±2°				

PRELIMINARY DRAWING