

TLS203B0 DEMO Board User Guide

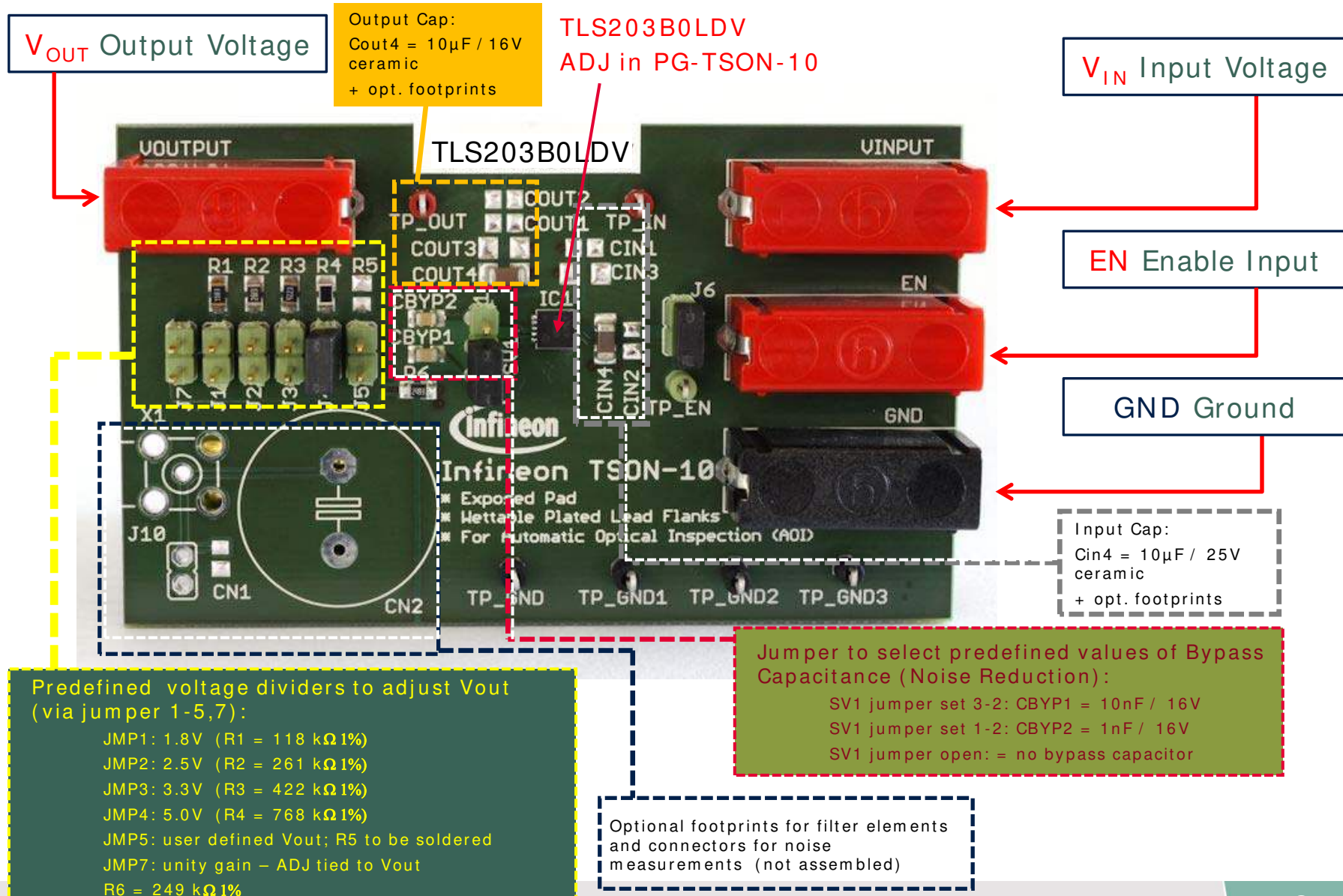

Board Overview and Quick Start



Quick Start

- › Select the desired Output Voltage V_{OUT} :
 - close ONE of the jumpers JMP 1-5 according to page 2. If JMP5 is used (= user-specific) a user defined value for R5 must be soldered accordingly. If $V_{OUT} > 16V$ is chosen the output capacitor must be replaced with a capacitor having a higher voltage rating (16V is assembled). Leave the other jumpers open!
- › Select Bypass Capacitance:
 - the jumper settings of SV1 allow to use pre-assembled bypass capacitor values C_{BYP} of either 10nF or 1nF. Leaving SV1 open corresponds to „no bypass capacitor used“.
- › Connect GND to Ground
- › Connect V_{IN} to the Voltage Supply
 - Absolute Maximum Rating V_{IN} : -20V to 20V
- › Connect V_{OUT} to the load
 - Absolute Maximum Rating V_{OUT} : -20V to 20V
- › Set **EN** to high level or connect to V_{IN} to start the voltage regulator
 - Absolute Maximum Rating EN: -20V to 20V
 - Jumper JMP6 can be used to tie V_{EN} to V_{IN}

Note: Do NOT exceed the Absolute Maximum Ratings!

Board Schematics

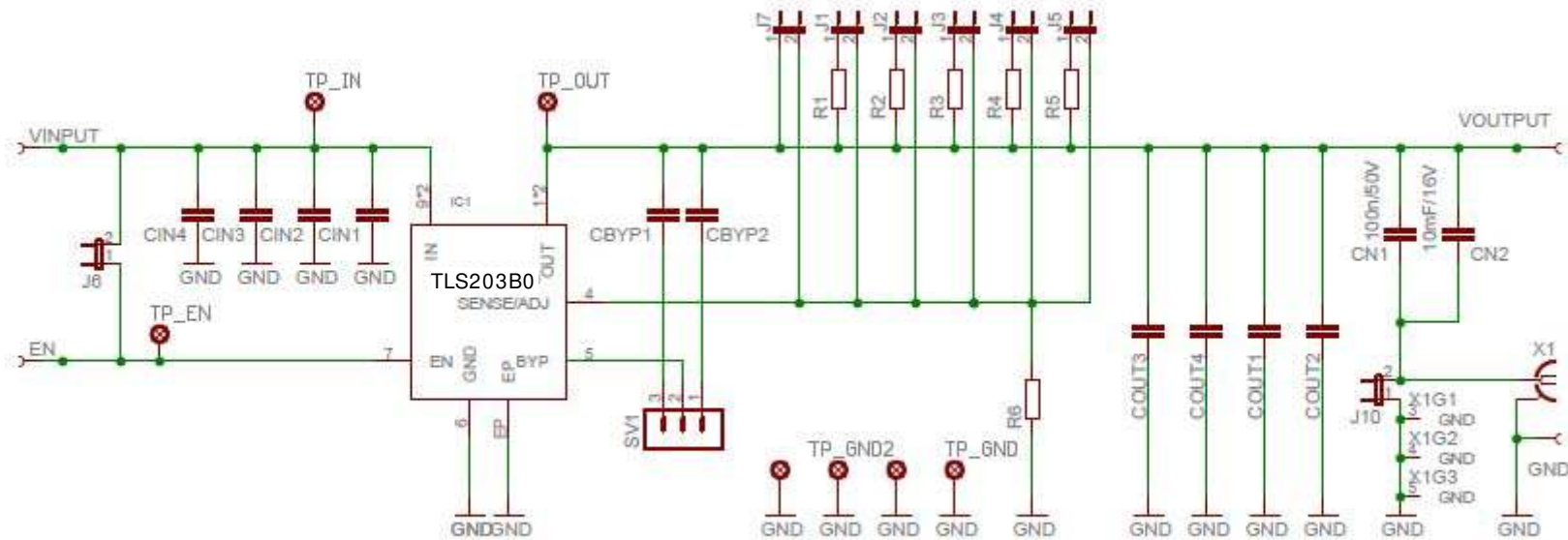

Board TOP Layer

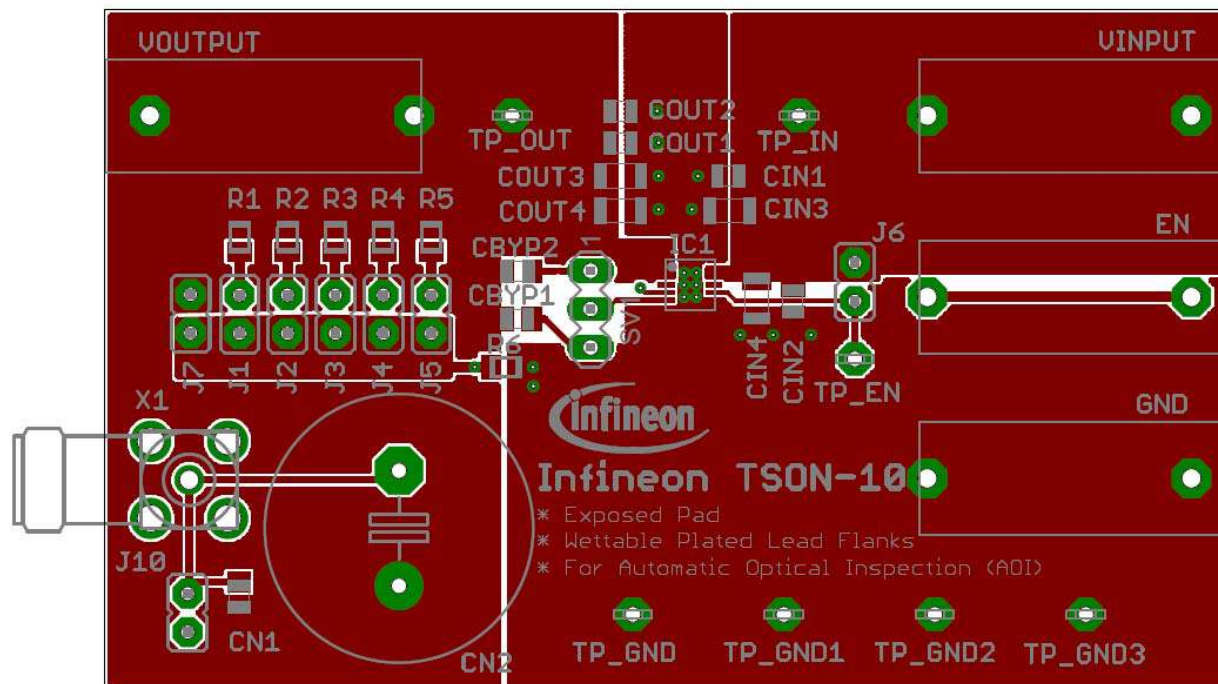

Board BOTTOM Layer

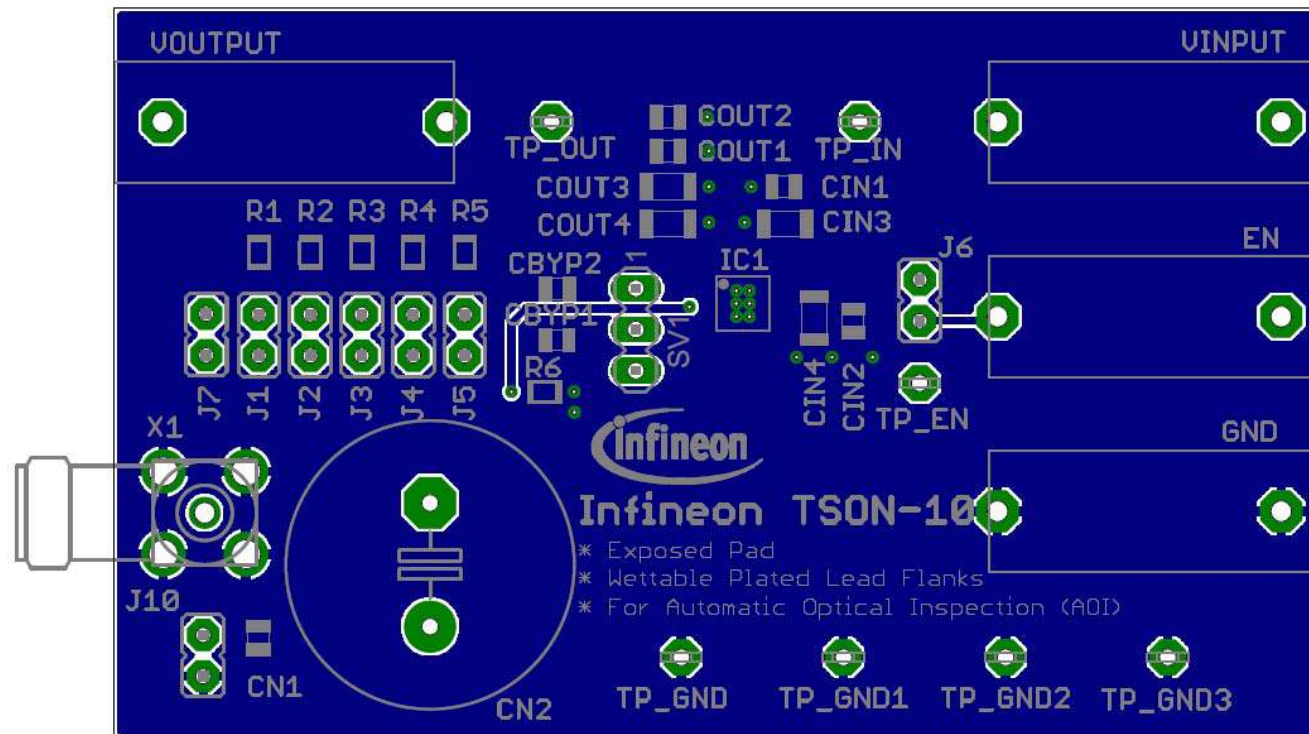



Part of your life. Part of tomorrow.

