

LOC		DIST		REVISIONS			
P	LTR	DESCRIPTION	DATE	DN	APVD		
S		REV PER ECO-15-016251	13NOV15	KG	CD		

1. THIS RECEPTACLE WILL MATE WITH ANY 21C4, SIZE 4 PLUG IN AMPLIMITE SERIES.
2. MAXIMUM WIRE INSULATION TO BE USED WITH THIS RECEPTACLE IS $\phi.072$.
3. RETENTION CLIPS (17) ARE INCLUDED IN INSERT ASSEMBLY.
4. THIS CONNECTOR ACCEPTS SIZE 20 SOCKET CONTACTS, NOT PROVIDED, IN CAVITIES 1 THRU 17.
5. CAVITIES A1 THRU A4 ACCEPTS SIZE 8 POWER, OR COAX SOCKET CONTACTS, NOT PROVIDED. RIGHT ANGLE COAX CONTACTS WILL NOT SEAT IN THIS CONNECTOR.

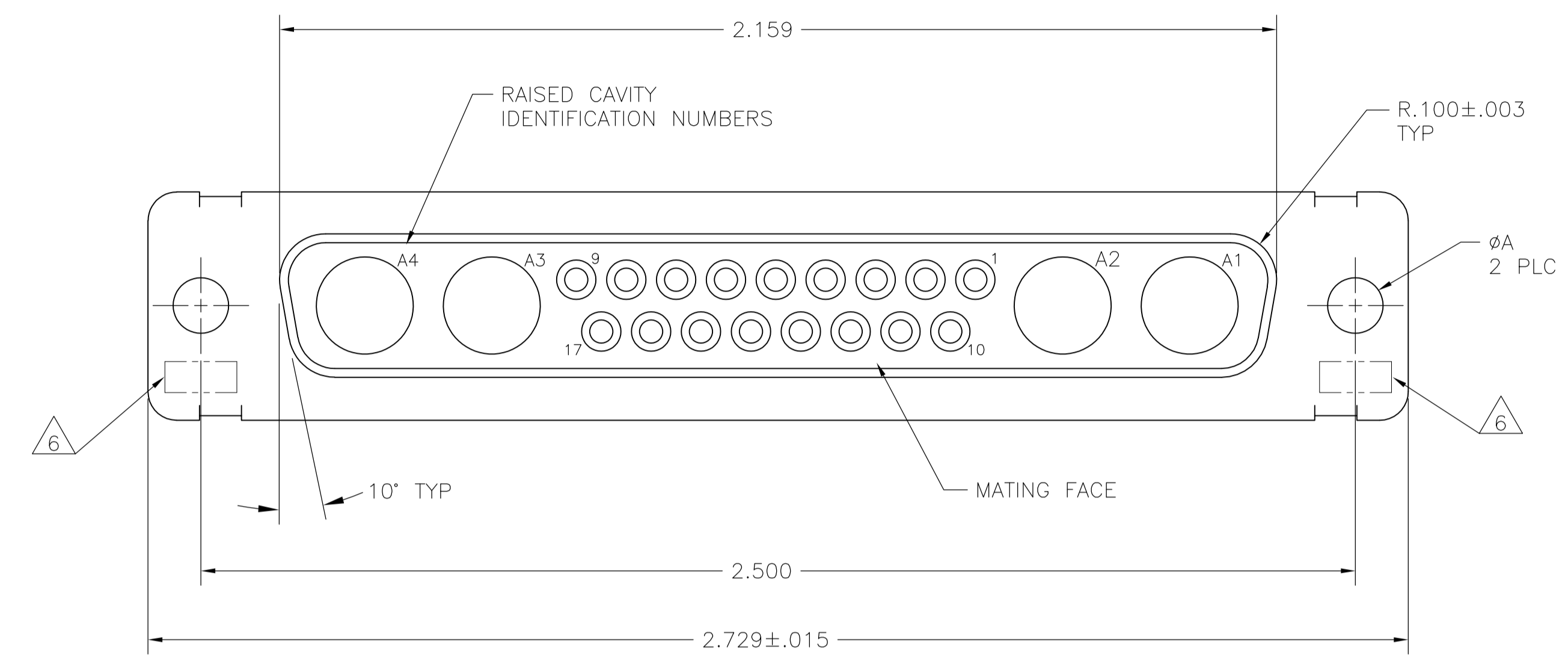

- △6 UL/CSA DESIGNATION STAMPED IN THIS AREA, OPTIONAL.
- △7 MATERIAL: STEEL PER ASTM-A-109.
- △8 FINISH: CADMIUM PLATED PER QQ-P-416, TYPE II, CLASS 2.
- △9 MATERIAL: BRASS PER ASTM-B-36.
- △10 FINISH: GOLD PER MIL-G-45204 TYPE II, GRADE C, CLASS 1 OVER COPPER PER MIL-C-14550, CLASS IV.
- △11 FINISH: TIN PER ASTM-B-545 .000400 MIN THK OVER COPPER PER AMS2418 .000050 MIN THK.
- △12 FINISH: ZINC PLATE PER ASTM-B-633 .000200-.000400 THK WITH SUPPLEMENTARY CHROMATE (Cr3+).

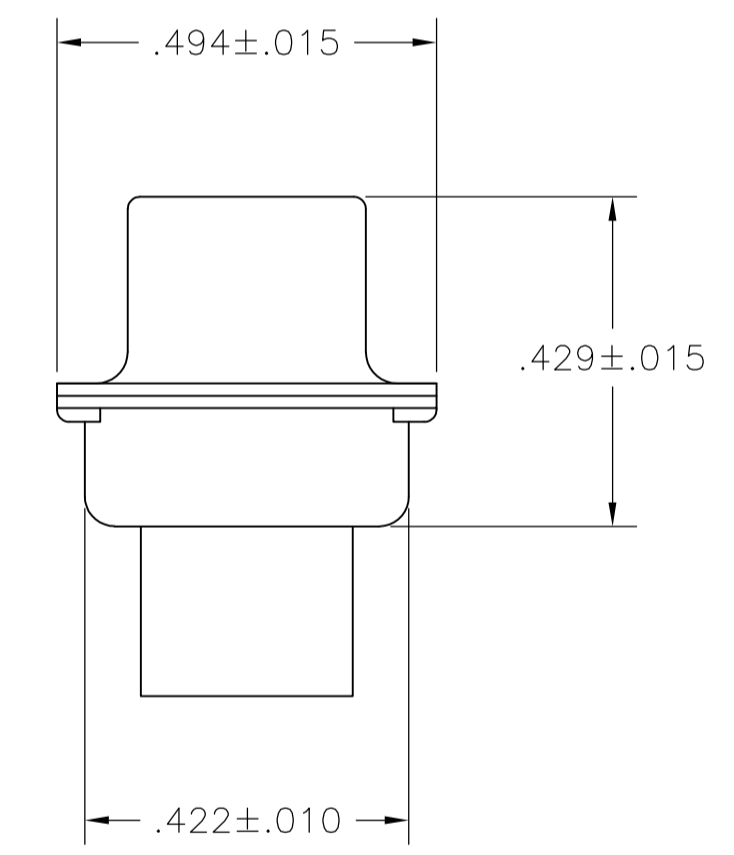
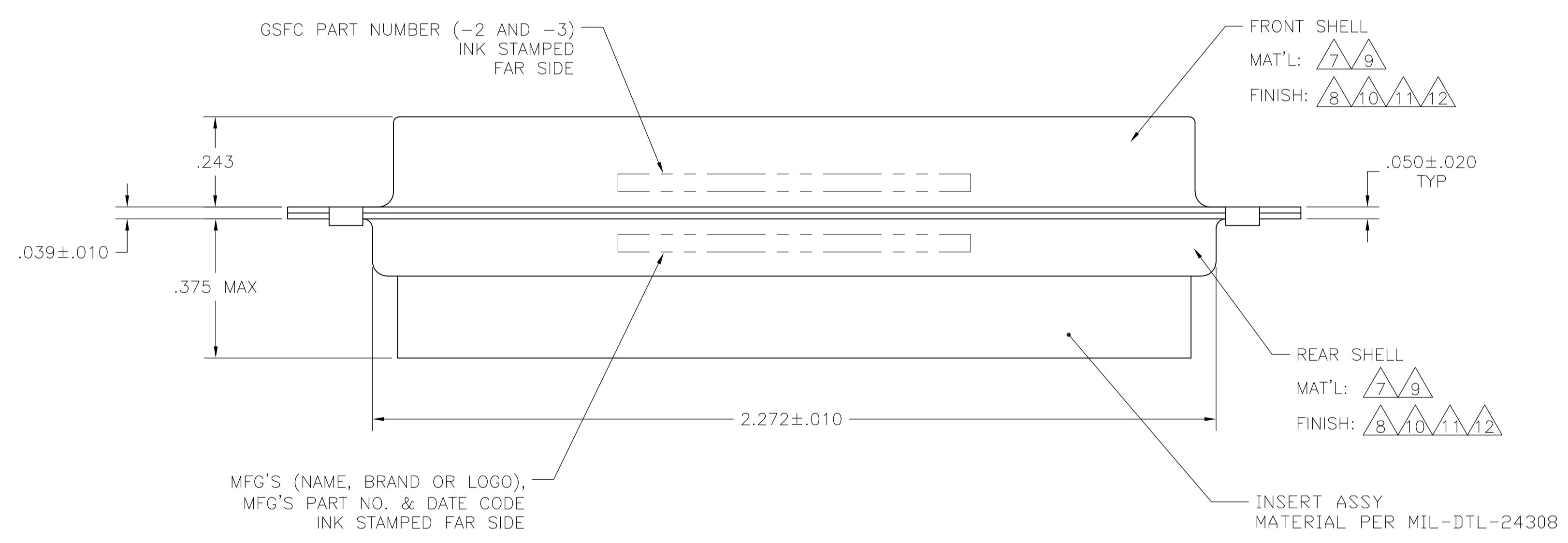

△7△11	.120	-	5-212534-4
△7△12	.120	-	5-212534-1
△7△11	.120	-	212534-5
△7△11	.120	-	212534-4
△9△10	.154	311P405-18S-B-15	212534-3
△9△10	.120	311P405-18S-B-12	212534-2
△7△8	.120	-	212534-1
REMARKS	φA	GSFC P/N	PART NO.

THIS DRAWING IS A CONTROLLED DOCUMENT. **STE** TE Connectivity

DIMENSIONS: INCHES	TOLERANCES UNLESS OTHERWISE SPECIFIED:	DIN C.C.THOMAS 21JAN88	APVD A.FMADI 27JAN88	NAME
0 PLC ± -	1 PLC ± -	2 PLC ± -	3 PLC ± .005(0.13)	4 PLC ± -
ANGLES ± -	± 0° 30'			
MATERIAL	FINISH	WEIGHT	SIZE	CAGE CODE
-	-	-	A1	00779
CUSTOMER DRAWING		SCALE	SHEET	REV
		4:1	1 of 1	S

RECEPTACLE ASSEMBLY
 AMPLIMITE 21C4
 SIZE 4, SERIES 109, COAX MIX