

Ⓐ REF. THIS DRAWING IS SUPERSEDED CADKEY DOC SD-39980-010 REV-B

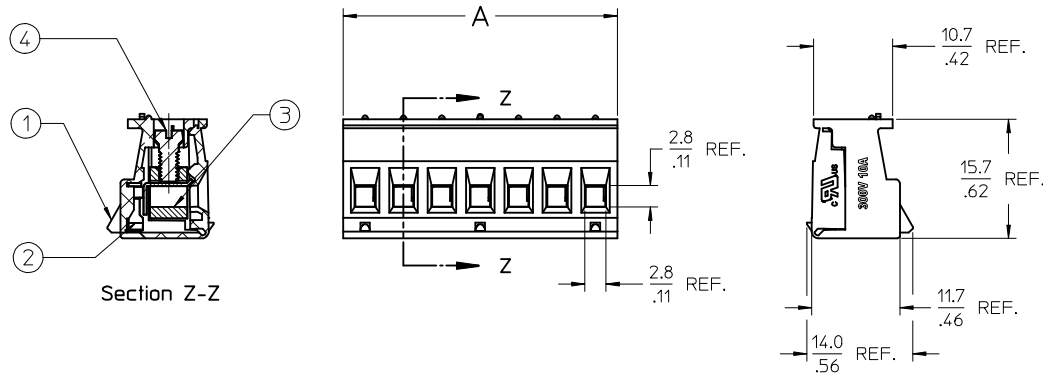
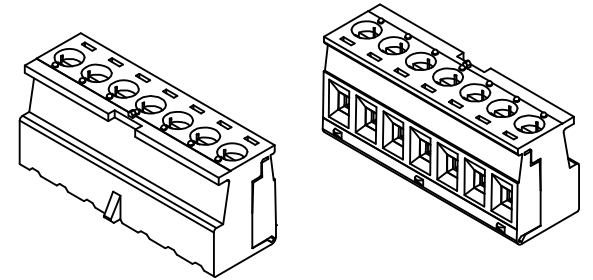
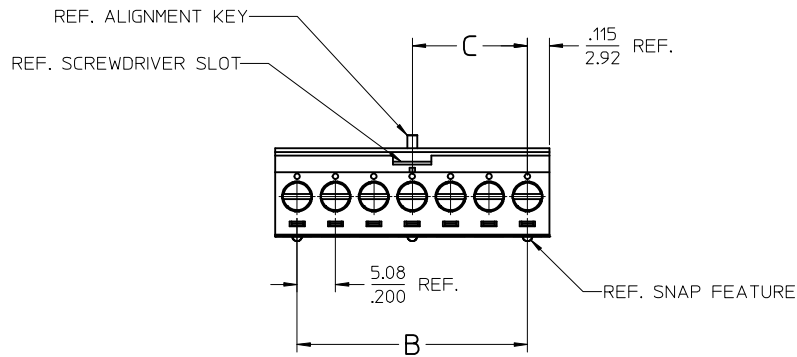

CIRCUITS	PART NO.	DIM-A mm ±0.25	DIM-A IN ±.010	DIM-B mm	DIM-B IN	DIM-C mm	DIM-C IN
2	399800302	10.92	.430	5.08	.200	5.08	.200
3	399800303	16.00	.630	10.16	.400	10.16	.400
4	399800304	21.08	.830	15.24	.600	10.16	.400
5	399800305	26.16	1.030	20.32	.800	10.16	.400
6	399800306	31.24	1.230	25.40	1.000	15.24	.600
7	399800307	36.32	1.430	30.48	1.200	15.24	.600
8	399800308	41.40	1.630	35.56	1.400	20.34	.800
9	399800309	46.48	1.830	40.64	1.600	20.34	.800
10	399800310	51.56	2.030	45.72	1.800	25.40	1.000
11	399800311	56.64	2.230	50.80	2.000	25.40	1.000
12	399800312	61.72	2.430	55.88	2.200	30.48	1.200
13	399800313	66.80	2.630	60.96	2.400	30.48	1.200
14	399800314	71.88	2.830	66.04	2.600	35.56	1.400
15	399800315	76.96	3.030	71.12	2.800	35.56	1.400
16	399800316	82.04	3.230	76.20	3.000	40.64	1.600
17	399800317	87.12	3.430	81.28	3.200	40.64	1.600
18	399800318	92.20	3.630	86.36	3.400	45.72	1.800
19	399800319	97.28	3.830	91.44	3.600	45.72	1.800
20	399800320	102.36	4.030	96.52	3.800	50.80	2.000
21	399800321	107.44	4.230	101.60	4.000	50.80	2.000
22	399800322	112.52	4.430	106.68	4.200	55.88	2.200
23	399800323	117.60	4.630	111.76	4.400	55.88	2.200
24	399800324	122.68	4.830	116.84	4.600	60.96	2.400

NOTES:

- MATERIAL: SEE TABLE
- FINISHES: SEE TABLE
- ELECTRICAL SPECIFICATIONS
VOLTAGE RATING: 300V
CURRENT RATING: 10 AMPS
- WIRE RANGE: 24-12AWG
- WIRE STRIP: 6mm (.25 IN)
- TIGHTENING TORQUE: .45NM (4 IN.LBS)
- XX REFERS TO NUMBER OF CIRCUITS

ITEM	QTY.	DESCRIPTION	MATERIAL	FINISH
4	XX	SCREW, M3 X 0.5	STEEL	ZN, CLEAR CHROMATE
3	XX	CAGE	BRASS	NICKEL PLATED
2	XX	TERMINAL	Cu ALLOY	TIN PLATED
1	1	PLUG BODY	NYLON	BLACK

REDRAWN: REMOVE GOLD OPT	QUALITY SYMBOLS
EC NO: IPG2016-1388	▽=0
DRAWN: RSTONE 2016/04/13	▽=0
CHKD: MZILELSKI 2016/04/20	
APPR: BRUPERT 2016/04/22	
DESCRIPTION	

GENERAL TOLERANCES (UNLESS SPECIFIED)	ANGULAR ±----
mm	INCH
4 PLACES ±---	±---
3 PLACES ±---	±.005
2 PLACES ±0.13	±.01
1 PLACE ±0.3	±---
0 PLACE ±---	±---
DRAFT WHERE APPLICABLE MUST REMAIN WITHIN DIMENSIONS	

DIMENSION STYLE	SCALE	DESIGN UNITS	THIRD ANGLE PROJECTION
MM/IN	2:1	INCH	
DRAWN BY	DATE	TITLE	
RSTONE	2016/04/13	SINGLE ROW EURO PLUG	
CHECKED BY	DATE	5.08MM (.200 IN) PITCH	
MZILELSKI	2016/04/20		
APPROVED BY	DATE		
BRUPERT	2016/04/22		
MATERIAL NO.	DOCUMENT NO.	SHEET NO.	
SEE TABLE	SD-39980-012	1 OF 1	

THIS DRAWING CONTAINS INFORMATION THAT IS PROPRIETARY TO MOLEX INCORPORATED AND SHOULD NOT BE USED WITHOUT WRITTEN PERMISSION			
---	--	--	--