

083(M)

FILTERED POWER ENTRY MODULES WITH DOUBLE FUSE HOLDER (GENERAL PURPOSE & MEDICAL)

FEATURES

- » Rated currents include **1A, 3A, 6A, and 10A**
- » Single Stage
- » Available with quick disconnect tabs and wire leads options
- » General Purpose & Low Leakage (M)edical options
- » Compact double safety fuse modules
- » Easy to use IEC inlet power entry filters with two safety fuses (on line and neutral)
- » Agency Approved to *UL and EN 60939, CSA C22.2*
- » Y-cap value can be adjusted



ELECTRICAL SCHEMATIC

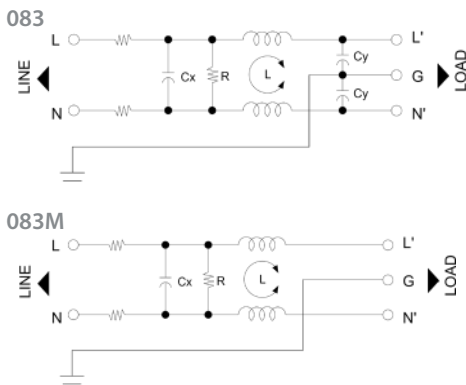

HOW TO ORDER

083M.0ZZ01.00-T



NOTE: USE ANY COMBINATOR OF **M, ZZ** AND **T**

E.G. **083.00101.00** (1A GENERAL PURPOSE VERSION) | **083M.00301.00** (3A LOW LEAKAGE MEDICAL VERSION)

SPECIFICATIONS

OPERATING FREQUENCY	50/60Hz
IEC INLET	C14
MAX. OPERATING VOLTAGE	250VAC +10%
CLIMATIC CATEGORY	25/85/21
TERMINALS (-T)	0.25" TABS W: WIRE LEADS
TYP. WEIGHT, LBS (KG)	0.10 (0.04)

TYPICAL LEAKAGE CURRENT 080

@ 250 VAC 50 Hz	0 - 0.42 mA Max.
@ 120 VAC 60 Hz	0 - 0.23 mA Max.

TYPICAL LEAKAGE CURRENT 080M

@ 250 VAC 50 Hz	0 - 10uA Max.
@ 120 VAC 60 Hz	0 - 5uA Max.

HIPOT RATINGS

LINE TO LINE	1450 VDC
LINE TO GROUND	2250 VDC

TYPICAL APPLICATIONS

- ✓ Household appliances and equipment
- ✓ Small medical equipment
- ✓ Portable electrical and electronic equipment
- ✓ Test and measurement/lab equipment
- ✓ Rack mounted equipment

083(M)

FILTERED POWER ENTRY MODULES WITH DOUBLE FUSE HOLDER (GENERAL PURPOSE & MEDICAL)

MODEL NO.	RATED CURRENT, A @ 40° C	TERMINAL OPTIONS		APPLICATION PURPOSE		MAX. DIMENSIONS" (MM)		
		(QD) OUTPUT	(W) OUTPUT	GENERAL	MEDICAL	WIDTH	(LENGTH)	HEIGHT
083.00101.00	1	✓	✓	✓		1.12"(29)	2.00"(51)	1.34"(34)
083.00301.00	3	✓	✓	✓		1.12"(29)	2.00"(51)	1.34"(34)
083.00601.00	6	✓	✓	✓		1.12"(29)	2.00"(51)	1.34"(34)
083.01001.00	10	✓	✓	✓		1.12"(29)	2.00"(51)	1.34"(34)
083M.00101.00	1	✓	✓		✓	1.12"(29)	2.00"(51)	1.34"(34)
083M.00301.00	3	✓	✓		✓	1.12"(29)	2.00"(51)	1.34"(34)
083M.00601.00	6	✓	✓		✓	1.12"(29)	2.00"(51)	1.34"(34)
083M.01001.00	10	✓	✓		✓	1.12"(29)	2.00"(51)	1.34"(34)

083(M) MECHANICAL OUTLINES (MM)

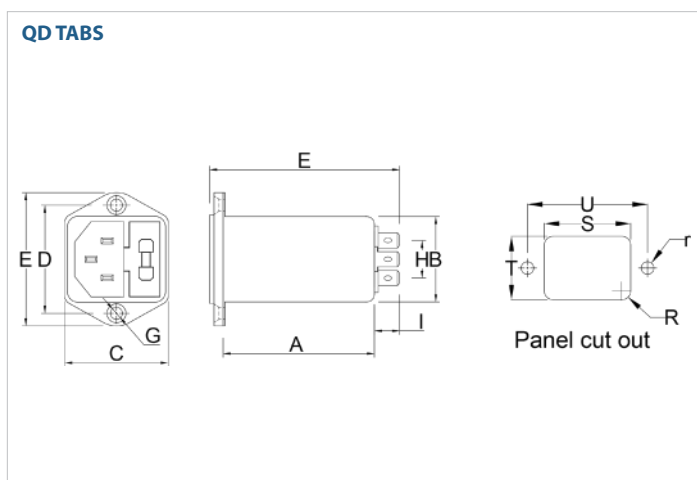

SERIES	(A)	B	C	D	E	F	G	H	I	U	S	T	R	r
QD TABS	2.00" (51)	1.12" (29)	1.34" (34)	1.42" (36)	2.60" (66)	1.75" (45)	2*4.0	0.47" (12)	0.35" (9)	1.42" (36)	1.16" (30)	1.32" (34)	0.12" (3)	0.17" (4)

TYPICAL TOLERANCE: +/-0.02" (0.50MM)

083(M)

FILTERED POWER ENTRY MODULES WITH DOUBLE FUSE HOLDER
(GENERAL PURPOSE & MEDICAL)

TYPICAL INSERTION LOSS, dB (50/50 Ohm)

083 INSERTION LOSS

Amps	Freq (MHz)	0.15	0.5	1	10	30
1	CM (dB)	41.0	53.0	56.0	55.0	50.0
	DM (dB)	18.0	28.0	32.0	50.0	50.0
3	CM (dB)	37.0	49.0	51.0	50.0	50.0
	DM (dB)	18.0	28.0	32.0	50.0	50.0
6	CM (dB)	25.0	35.0	38.0	48.0	45.0
	DM (dB)	18.0	28.0	32.0	50.0	50.0
10	CM (dB)	18.0	26.0	28.0	42.0	40.0
	DM (dB)	18.0	28.0	32.0	50.0	50.0

083M INSERTION LOSS

Amps	Freq (MHz)	0.15	0.5	1	10	30
1	CM (dB)	41.0	49.0	51.0	27.0	17.0
	DM (dB)	18.0	28.0	32.0	50.0	50.0
3	CM (dB)	37.0	45.0	43.0	23.0	15.0
	DM (dB)	18.0	28.0	32.0	50.0	50.0
6	CM (dB)	25.0	31.0	33.0	23.0	15.0
	DM (dB)	18.0	28.0	32.0	50.0	50.0
10	CM (dB)	18.0	24.0	26.0	10.0	8.0
	DM (dB)	18.0	28.0	32.0	50.0	50.0