



PowerPC 750TM SCM RISC Microprocessor for the PID8p-750

Version 2.0

09/30/1999

IBM Microelectronics Division



Notices

Before using this information and the product it supports, be sure to read the general information on the back cover of this book.

Trademarks

The following are trademarks of International Business Machines Corporation in the United States, or other countries, or both:

IBM

IBM Logo

PowerPC

AIX

PowerPC 750

Preliminary Edition (Version 2.0, 09/30/1999)

This document is the preliminary edition of *PowerPC 750TM* SCM RISC Microprocessor for the PID8p-750.

This document contains information on a new product under development by IBM. IBM reserves the right to change or discontinue this product without notice.

© International Business Machines Corporation 1999.
All rights reserved.



Preface 1

Overview 2

Features 3

General Parameters 5

Electrical and Thermal Characteristics 6

AC Electrical Characteristics 10

IEEE 1149.1 AC Timing Specifications 20

PowerPC PID8p-750 Microprocessor Pin Assignments 23

PowerPC PID8p-750 Microprocessor Pinout Listings 24

PowerPC PID8p-750 Microprocessor Package Description 27

System Design Information 30

Ordering Information 40

Processor Version Register (PVR) 40



Preface

The PowerPC PID8p-750 microprocessor is an implementation of the PowerPC™ family of reduced instruction set computer (RISC) microprocessors. In this document, the term “PID8p-750” is used as an abbreviation for the phrase “PowerPC 750 SCM RISC Microprocessor Family: PID8p-750 microprocessor.”

This document contains pertinent physical characteristics of the PID8p-750 Single Chip Modules (SCM) and covers the following topics:

Topic

- Overview (page 2)
- Features (page 3)
- General Parameters (page 5)
- Electrical and Thermal Characteristics (page 6)
- PowerPC PID8p-750 Microprocessor Pin Assignments (page 23)
- PowerPC PID8p-750 Microprocessor Pinout Listings (page 24)
- PowerPC PID8p-750 Microprocessor Package Description (page 27)
- System Design Information (page 30)
- Ordering Information (page 40)

New features/deletions for rev level dd3.x:

- Selectable I/O voltages on 60X bus (pin W1) and L2 bus (pin A19). See Table , “Recommended Operating Conditions^{1,2,3},” on page 6. Older revs must leave these pins “no connect” or “tied high” for 3.3v I/Os. AC timings are the same for all I/O voltage modes unless otherwise noted. The 1.8v I/O is selected by tying the I/O select pin to ground. If a pull down resistor is necessary, the resistor value must be no more than 10 ohms.
- 60X bus to core frequency now also supports the 10x ratio. See Table , “PID8p-750 Microprocessor PLL Configuration,” on page 30 for how to set this ratio.
- Extra output hold on the 60X bus by L2_TSTCLK pin tied low is no longer available. The L2_TSTCLK pin must now be tied to OV_{DD} for normal operation. See Table , “60X Bus Output AC Timing Specifications¹,” on page 13.

Overview

The PID8p-750 is targeted for high performance, low power systems and supports the following power management features: doze, nap, sleep, and dynamic power management. The PID8p-750 consists of a processor core and an internal L2 Tag combined with a dedicated L2 cache interface and a 60x bus.

Figure 1 shows a block diagram of the PID8p-750.

Figure 1. PID8p-750 Block Diagram

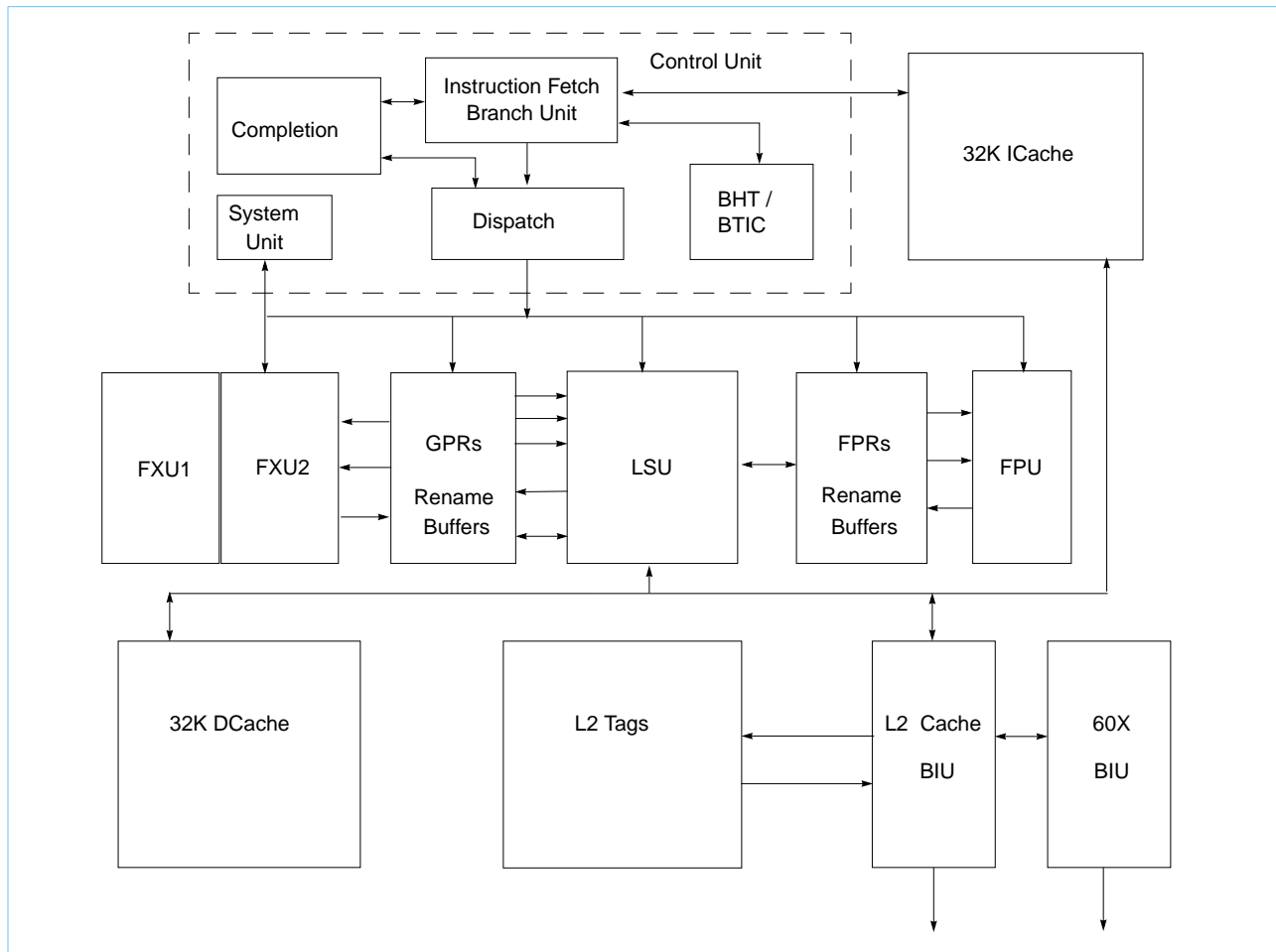

Features

This section summarizes features of the PID8p-750's implementation of the PowerPC architecture. Major features of the PID8p-750 are as follows.

- Branch processing unit
 - Four instructions fetched per clock.
 - One branch processed per cycle (plus resolving 2 speculations).
 - Up to 1 speculative stream in execution, 1 additional speculative stream in fetch.
 - 512-entry branch history table (BHT) for dynamic prediction.
 - 64-entry, 4-way set associative branch target instruction cache (BTIC) for eliminating branch delay slots.
- Dispatch unit
 - Full hardware detection of dependencies (resolved in the execution units).
 - Dispatch two instructions to six independent units (system, branch, load/store, fixed-point unit 1, fixed-point unit 2, or floating-point).
 - Serialization control (predispatch, postdispatch, execution, serialization).
- Decode
 - Register file access.
 - Forwarding control.
 - Partial instruction decode.
- Load/store unit
 - One cycle load or store cache access (byte, half-word, word, double-word).
 - Effective address generation.
 - Hits under misses (one outstanding miss).
 - Single-cycle misaligned access within double word boundary.
 - Alignment, zero padding, sign extend for integer register file.
 - Floating-point internal format conversion (alignment, normalization).
 - Sequencing for load/store multiples and string operations.
 - Store gathering.
 - Cache and TLB instructions.
 - Big and little-endian byte addressing supported.
 - Misaligned little-endian support in hardware.
- Fixed-point units
 - Fixed-point unit 1 (FXU1); multiply, divide, shift, rotate, arithmetic, logical.
 - Fixed-point unit 2 (FXU2); shift, rotate, arithmetic, logical.
 - Single-cycle arithmetic, shift, rotate, logical.
 - Multiply and divide support (multi-cycle).
 - Early out multiply.
- Floating-point unit
 - Support for IEEE-754 standard single- and double-precision floating-point arithmetic.
 - 3 cycle latency, 1 cycle throughput, single-precision multiply-add.
 - 3 cycle latency, 1 cycle throughput, double-precision add.
 - 4 cycle latency, 2 cycle throughput, double-precision multiply-add.
 - Hardware support for divide.
 - Hardware support for denormalized numbers.
 - Time deterministic non-IEEE mode.
- System unit
 - Executes CR logical instructions and miscellaneous system instructions.

- Special register transfer instructions.
- Cache structure
 - 32K, 32-byte line, 8-way set associative instruction cache.
 - 32K, 32-byte line, 8-way set associative data cache.
 - Single-cycle cache access.
 - Pseudo-LRU replacement.
 - Copy-back or write-through data cache (on a page per page basis).
 - Supports all PowerPC memory coherency modes.
 - Non-blocking instruction and data cache (one outstanding miss under hits).
 - No snooping of instruction cache.
- Memory management unit
 - 128 entry, 2-way set associative instruction TLB.
 - 128 entry, 2-way set associative data TLB.
 - Hardware reload for TLB's.
 - 4 instruction BAT's and 4 data BATs.
 - Virtual memory support for up to 4 exabytes (2^{52}) virtual memory.
 - Real memory support for up to 4 gigabytes (2^{32}) of physical memory.
- Level 2 (L2) cache interface
 - Internal L2 cache controller and 4K-entry tags; external data SRAMs.
 - 256K, 512K, and 1 Mbyte 2-way set associative L2 cache support.
 - Copy-back or write-through data cache (on a page basis, or for all L2).
 - 64-byte (256K/512K) and 128-byte (1-Mbyte) sectored line size.
 - Supports flow-through (reg-buf) synchronous burst SRAMs, pipelined (reg-reg) synchronous burst SRAMs, and pipelined (reg-reg) late-write synchronous burst SRAMs.
 - Design supports Core-to-L2 frequency divisors of $\div 1$, $\div 1.5$, $\div 2$, $\div 2.5$, and $\div 3$. However, this specification supports the L2 frequency range specified in Section "L2 Clock AC Specifications," on page 15. For higher L2 frequencies not supported in this document, please contact your IBM marketing representative.
- Bus interface
 - Compatible with 60x processor interface.
 - 32-bit address bus.
 - 64-bit data bus.
 - Bus-to-core frequency multipliers of 3x, 3.5x, 4x, 4.5x, 5x, 5.5x, 6x, 6.5x, 7x, 7.5x, 8x and 10x supported (10x on rev level dd3.x only).
- Integrated power management
 - Low-power 2.0/3.3V design.
 - Three static power saving modes: doze, nap, and sleep.
 - Automatic dynamic power reduction when internal functional units are idle.
- Integrated Thermal Management Assist Unit
 - On-chip thermal sensor and control logic.
 - Thermal Management Interrupt for software regulation of junction temperature.
- Testability
 - LSSD scan design.
 - JTAG interface.
- Reliability and serviceability—Parity checking on 60x and L2 cache buses

General Parameters

The following list provides a summary of the general parameters of the PID8p-750.

Technology	0.20 μ m CMOS (general lithography), six-layer copper metallization 0.12 \pm 0.04 μ m L _{eff}
Die Size	5.14mm x 7.78mm (40mm ²)
Transistor count	6.35 million
Logic design	Fully-static
Package	PID8p-750: Surface mount 360-lead ceramic ball grid array (CBGA) with L2 interface.
Core power supply	2.05 \pm 50mV _{DC}
I/O power supply	3.3V \pm 5% 2.5V \pm 5% 1.8V \pm 5%

Electrical and Thermal Characteristics

This section provides both AC and DC electrical specifications and thermal characteristics for the PID8p-750.

DC Electrical Characteristics

The tables in this section describe the PID8p-750's DC electrical characteristics. The following table provides the absolute maximum ratings.

Absolute Maximum Ratings

Characteristic	Symbol	Value	Unit
Core supply voltage	V_{DD}	-0.3 to 2.5	V
PLL supply voltage	AV_{DD}	-0.3 to 2.5	V
L2 DLL supply voltage	$L2AV_{DD}$	-0.3 to 2.5	V
60x bus supply voltage (maximum)	$OV_{DD(3.3V)}$	-0.3 to 3.6	V
	$OV_{DD(2.5V)}$	-0.3 to 2.8	
	$OV_{DD(1.8V)}$	-0.3 to 2.1	
L2 bus supply voltage (maximum)	$L2OV_{DD}$	-0.3 to 3.6	V
Input voltage (maximum)	$V_{IN(3.3V)}$	-0.3 to 3.6	V
	$V_{IN(2.5V)}$	-0.3 to 2.8	
	$V_{IN(1.8V)}$	-0.3 to 2.1	
Storage temperature range	T_{STG}	-55 to 150	°C

Note:

- Functional and tested operating conditions are given in Table "Recommended Operating Conditions^{1,2,3}" below. Absolute maximum ratings are stress ratings only, and functional operation at the maximums is not guaranteed. Stresses beyond those listed may affect device reliability or cause permanent damage to the device.
- Caution:** V_{IN} must not exceed OV_{DD} by more than 0.3V at any time, including during power-on reset.
- Caution:** $OV_{DD}/L2OV_{DD}$ must not exceed V_{DD}/AV_{DD} by more than 2.0V during normal operation. On power up and power down, $OV_{DD}/L2OV_{DD}$ must not exceed V_{DD}/AV_{DD} by more than 3.3V and for no more than 20ms.
- Caution:** V_{DD}/AV_{DD} must not exceed $OV_{DD}/L2OV_{DD}$ by more than 0.4V during normal operation. On power up and power down, V_{DD}/AV_{DD} must not exceed $OV_{DD}/L2OV_{DD}$ by more than 1.0V and for no more than 20ms.

The following table provides the recommended operating conditions for the PID8p-750.

Recommended Operating Conditions^{1,2,3}

Characteristic	Symbol	Value	Unit
Core supply voltage	V_{DD}	2.0 to 2.1	V
PLL supply voltage	AV_{DD}	2.0 to 2.1	V
L2 DLL supply voltage	$L2AV_{DD}$	2.0 to 2.1	V
60x bus supply voltage, pin W1 tied high	$OV_{DD(3.3V)}$	3.135 to 3.465	V
60x bus supply voltage, pin W1 tied to HRESET	$OV_{DD(2.5V)}$	2.375 to 2.625	V
60x bus supply voltage, pin W1 tied to GND	$OV_{DD(1.8V)}$	1.71 to 1.89	V
L2 bus supply voltage, pin A19 tied high	$L2OV_{DD(3.3V)}$	3.135 to 3.465	V

Note:

- These are recommended and tested operating conditions. Proper device operation outside of these conditions is not guaranteed.
- For dd3.x, if W1 is left unconnected, the 60X bus will default to $OV_{DD} = 3.3V$. For dd2x, W1=Don't care
- For dd3.x, if A19 is left unconnected, the L2 bus will default to $L2OV_{DD} = 3.3V$. For dd2x, W1=Don't care



Recommended Operating Conditions^{1,2,3}

Characteristic	Symbol	Value	Unit
L2 bus supply voltage, pin A19 tied to HRESET	L2OV _{DD(2.5V)}	2.375 to 2.625	V
L2 bus supply voltage, pin A19 tied to GND	L2OV _{DD(1.8V)}	1.71 to 1.89	V
Input voltage (under AC conditions, inputs must go rail to rail for maximum AC timing performance)	V _{IN(60X)}	GND to OV _{DD}	V
	V _{IN(L2)}	GND to L2OV _{DD}	V
Die-junction temperature	T _J	0 to 105	°C

Note:

1. These are recommended and tested operating conditions. Proper device operation outside of these conditions is not guaranteed.
2. For dd3.x, If W1 is left unconnected, the 60X bus will default to OV_{DD} = 3.3V. For dd2x, W1=Don't care
3. For dd3.x, If A19 is left unconnected, the L2 bus will default to L2OV_{DD} = 3.3V. For dd2x, W1=Don't care

The following table provides the package thermal characteristics for the PID8p-750.

Package Thermal Characteristics

Characteristic	Symbol	Value	Unit
CBGA package thermal resistance, junction-to-case thermal resistance (typical)	θ _{JC}	0.03	°C/W
CBGA package thermal resistance, junction-to-lead thermal resistance (typical)	θ _{JB}	3.8	°C/W

Note: Refer to Section "Thermal Management Information," on page 34 for more information about thermal management.

The PID8p-750 incorporates a thermal management assist unit (TAU) composed of a thermal sensor, digital-to-analog converter, comparator, control logic, and dedicated special-purpose registers (SPRs). See the 750 RISC Microprocessor User's Manual for more information on the use of this feature. Specifications for the thermal sensor portion of the TAU are found in the table below.

Thermal Sensor Specifications

See Table "Recommended Operating Conditions^{1,2,3}," on page 6, for operating conditions.

Num	Characteristic	Minimum	Maximum	Unit	Notes
1	Temperature range	0	128	°C	1
2	Comparator settling time	20	—	ms	2
3	Resolution	4	—	°C	3

Note:

1. The temperature is the junction temperature of the die. The thermal assist unit's (TAU) raw output does not indicate an absolute temperature, but it must be interpreted by software to derive the absolute junction temperature. For information on how to use and calibrate the TAU, contact your local IBM sales office. This specification reflects the temperature span supported by the design.
2. The comparator settling time value must be converted into the number of CPU clocks that need to be written into the THRM3 SPR.
3. This value is guaranteed by design and is not tested.

The following table provides DC electrical characteristics for the PID8p-750.

DC Electrical Specifications

See Section “Recommended Operating Conditions 1,2,3,” on page 6, for operating conditions.

Characteristic	Symbol	Minimum	Maximum	Unit	Notes
Input high voltage (all inputs except SYSCLK)	$V_{IH(3.3V)}$	2.0	3.465	V	1,2
	$V_{IH(2.5V)}$	1.75	2.625		
	$V_{IH(1.8V)}$	1.4	1.89		
Input low voltage (all inputs except SYSCLK)	$V_{IL(3.3V)}$	GND	0.8	V	
	$V_{IL(2.5V)}$	GND	0.7		
	$V_{IL(1.8V)}$	GND	0.5		
SYSCLK input high voltage	$CV_{IH(3.3V)}$	2.0	3.465	V	1
	$CV_{IH(2.5V)}$	2.0	2.625		
	$CV_{IH(1.8V)}$	1.5	1.89		
SYSCLK input low voltage	CV_{IL}	GND	0.4	V	
Input leakage current, $V_{IN} = OV_{DD}$	I_{IN}	–	20	μA	1,2
Hi-Z (off state) leakage current, $V_{IN} = OV_{DD}$	I_{TSL}	–	20	μA	1,2
Output high voltage, $I_{OH} = -6mA$	$V_{OH(3.3V)}$	2.4	–	V	
Output high voltage, $I_{OH} = -6mA$	$V_{OH(2.5V)}$	1.9	–	V	
Output high voltage, $I_{OH} = -3mA$	$V_{OH(1.8V)}$	1.4	–	V	
Output low voltage, $I_{OL} = 6mA$	$V_{OL(3.3V,2.5V,1.8V)}$	–	0.4	V	
Capacitance, $V_{IN} = 0V$, $f = 1MHz$	C_{IN}	–	5.0	pF	2,3

Note:

1. For 60x bus signals, the reference is OV_{DD} , while $L2OV_{DD}$ is the reference for the L2 bus signals.
2. Excludes test signals LSSD_MODE, L1_TSTCLK, L2_TSTCLK, and IEEE 1149.1 signals.
3. Capacitance values are guaranteed by design and characterization, and are not tested.



The next table provides the power consumption for the PID8p-750.

Power Consumption

See Table “Recommended Operating Conditions1,2,3,” on page 6, for operating conditions

	Processor CPU Frequency										Unit	Notes
	300	333	350	366	375	400	433	450	466	500		
Full-On Mode												
Typical	3.8	4.1	4.2	4.4	4.5	4.7	5.0	5.2	5.5	6.0	W	1,3,5
Maximum	4.5	5.0	5.2	5.5	5.7	6.0	6.3	6.6	6.8	7.5	W	1,2,4,5
Doze Mode												
Maximum	1.7	1.7	1.7	1.8	1.8	1.9	2.1	2.1	2.2	2.3	W	1,2,5
Nap Mode												
Maximum	250	250	250	250	250	250	250	250	250	250	mW	1,5
Sleep Mode												
Maximum	TBD	TBD	TBD	TBD	TBD	TBD	TBD	TBD	TBD	TBD	mW	1,5
Note:												
<ol style="list-style-type: none"> 1. These values apply for all valid 60x bus and L2 bus ratios. The values do not include I/O Supply Power (OV_{DD} and $L2OV_{DD}$) or PLL/DLL supply power (AV_{DD} and $L2AV_{DD}$). OV_{DD} and $L2OV_{DD}$ power is system dependent, but is typically <10% of V_{DD} power. Worst case power consumption for $AV_{DD} = 15mW$ and $L2AV_{DD} = 15mW$. 2. Maximum power is measured at $V_{DD} = AV_{DD} = L2AV_{DD} = 2.1V$, $OV_{DD} = L2OV_{DD} = 3.3V$, $65^{\circ}C$ in a system executing worst case benchmark sequences. 3. Typical power is an average value measured at $V_{DD} = AV_{DD} = L2AV_{DD} = 2.05V$, $OV_{DD} = L2OV_{DD} = 3.3V$, $45^{\circ}C$, in a system executing typical applications and benchmark sequences. 4. Maximum power at $85^{\circ}C$ may be derived by adding 0.1W to the maximum power number at $65^{\circ}C$. Similarly, maximum power at $105^{\circ}C$ may be derived by adding 0.3W to the maximum power at $65^{\circ}C$. 5. Guaranteed by design and characterization, and is not tested. 												

AC Electrical Characteristics

This section provides the AC electrical characteristics for the PID8p-750. After fabrication, parts are sorted by maximum processor core frequency as shown in the Section “Clock AC Specifications,” on page 10, and tested for conformance to the AC specifications for that frequency. These specifications are for 300MHz through 400MHz processor core frequencies. The processor core frequency is determined by the bus (SYSCLK) frequency and the settings of the PLL_CFG(0-3) signals. Parts are sold by maximum processor core frequency; see Section “Ordering Information,” on page 40.

Clock AC Specifications

The following table provides the clock AC timing specifications as defined in Figure 2.

Clock AC Timing Specifications⁸

See Table “Recommended Operating Conditions^{1,2,3},” on page 6, for operating conditions.

Num	Characteristic	300*, 333*, 350*, 366, 375MHz		400, 433, 450, 466, 500MHz		Unit	Notes
		Min	Max	Min	Max		
	Processor frequency	200	As per specified speed	250	As per specified speed	MHz	
	SYSCLK frequency	25	100	31	100	MHz	1
1	SYSCLK cycle time	10	40	10	32	ns	
2,3	SYSCLK rise and fall time	–	1.0	–	1.0	ns	2,3
4	SYSCLK duty cycle measured at $OV_{DD}/2$	40	60	40	60	%	3,7
	SYSCLK jitter	–	±150	–	±150	ps	4,3
	Internal PLL relock time	–	100	–	100	µs	5

Note:

1. Caution: The SYSCLK frequency and the PLL_CFG[0-3] settings must be chosen such that the resulting SYSCLK (bus) frequency, CPU (core) frequency, and PLL (VCO) frequency do not exceed their respective maximum or minimum operating frequencies. Refer to the PLL_CFG[0-3] signal description in Section “PLL Configuration,” on page 30 for valid PLL_CFG[0-3] settings.
2. Rise and fall times for the SYSCLK input are measured from 0.5v to 1.5v
3. Timing is guaranteed by design and characterization, and is not tested.
4. The total input jitter (short term and long term combined) must be under ±150ps.
5. Relock timing is guaranteed by design and characterization, and is not tested. PLL-relock time is the maximum amount of time required for PLL lock after a stable V_{DD} and SYSCLK are reached during the power-on reset sequence. This specification also applies when the PLL has been disabled and subsequently re-enabled during sleep mode. Also note that HRESET must be held asserted for a minimum of 255 bus clocks after the PLL-relock time during the power-on reset sequence.
6. * Subject to availability - see your marketing representative.
7. Duty cycle for 1.8, 2.5, and 3.3v I/Os.
8. SYSCLK input levels must not be higher than the absolute maximum ratings table for V_{IN} . See Table , “Absolute Maximum Ratings,” on page 6.

Figure 2. SYSCLK Input Timing Diagram

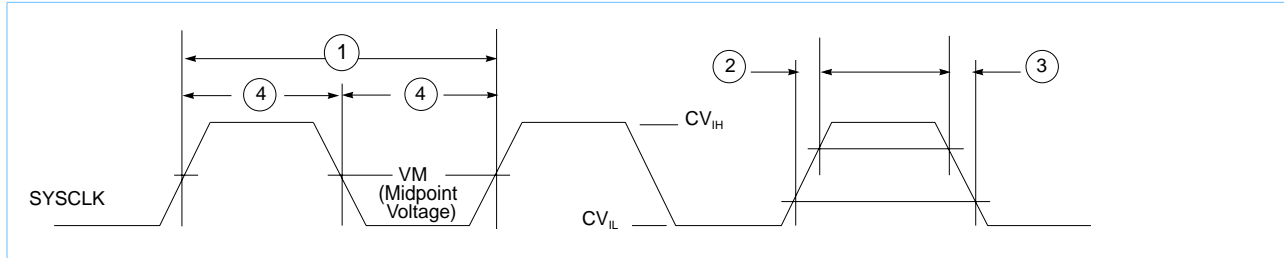

60x Bus Input AC Specifications

The following table provides the 60X bus input AC timing specifications for the PID8p-750 as defined in Figure 3 and Figure 4. Input timing specifications for the L2 bus are provided in Section, “L2 Bus Input AC Specifications” on page 17.

60X Bus Input Timing Specifications¹

See Table “Recommended Operating Conditions 1,2,3,” on page 6, for operating conditions.

Num	Characteristic	300,333, 350, 366, 375, 400, 433, 450, 466, 500 MHz		Unit	Notes
		Minimum	Maximum		
10a	Address/Data/Transfer Attribute Inputs Valid to SYSCLK (Input Setup)	2.5	—	ns	2
10b	All Other Inputs Valid to SYSCLK (Input Setup)	2.5	—	ns	3
10c	Mode Select Input Setup to HRESET (DRTRY, TLBISYNC)	8	—	t _{sysclk}	4,5,6,7
11a	SYSCLK to Address/Data/Transfer Attribute Inputs Invalid (Input Hold)	0.6	—	ns	2
11b	SYSCLK to All Other Inputs Invalid (Input Hold)	0.6	—	ns	3
11c	HRESET to mode select input hold (DRTRY, TLBISYNC)	0	—	ns	4,6,7

Note:

- Input specifications are measured from the midpoint voltage of the signal in question to the midpoint voltage of the rising edge of the input SYSCLK. Input and output timings are measured at the pin (see Figure 3) Midpoint voltage (VM) is 1.4v for OVdd in 3.3v mode and OVDD/2 for all other I/O modes
- Address/Data Transfer Attribute inputs are composed of the following—A[0-31], AP[0-3], TT[0-4], TBST, TSIZ[0-2], GBL, DH[0-31], DL[0-31], DP[0-7].
- All other signal inputs are composed of the following—TS, ABB, DBB, ARTRY, BG, AACK, DBG, DBWO, TA, DRTRY, TEA, DBDIS, TBEN, QACK, TLBISYNC.
- The setup and hold time is with respect to the rising edge of HRESET (see Figure 4).
- t_{sysclk} is the period of the external clock (SYSCLK) in nanoseconds (ns). The numbers given in the table must be multiplied by the period of SYSCLK to compute the actual time duration (in ns) of the parameter in question.
- These values are guaranteed by design, and are not tested.
- This specification is for configuration mode select only. Also note that the HRESET must be held asserted for a **minimum of 255 bus clocks** after the PLL re-lock time during the power-on reset sequence.

Figure 3 provides the input timing diagram for the PID8p-750.

Figure 3. Input Timing Diagram

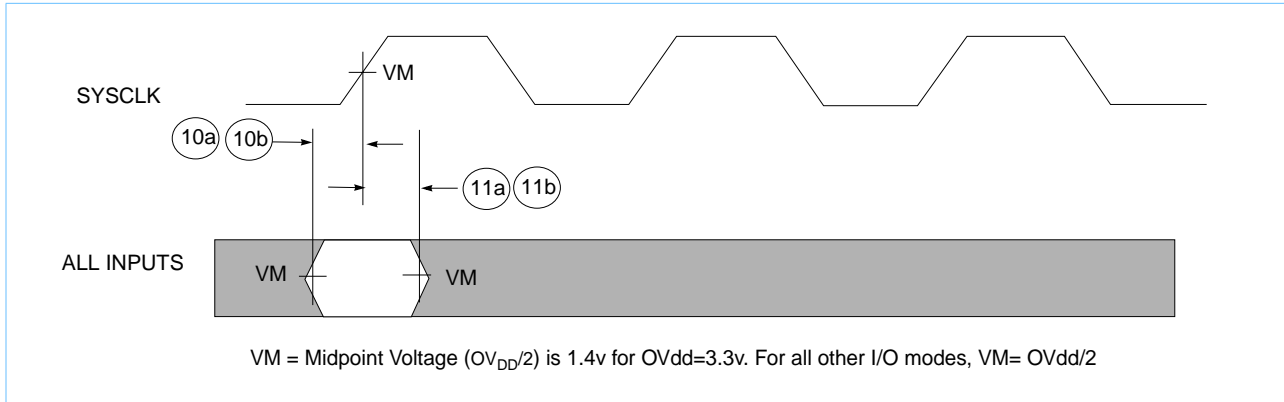
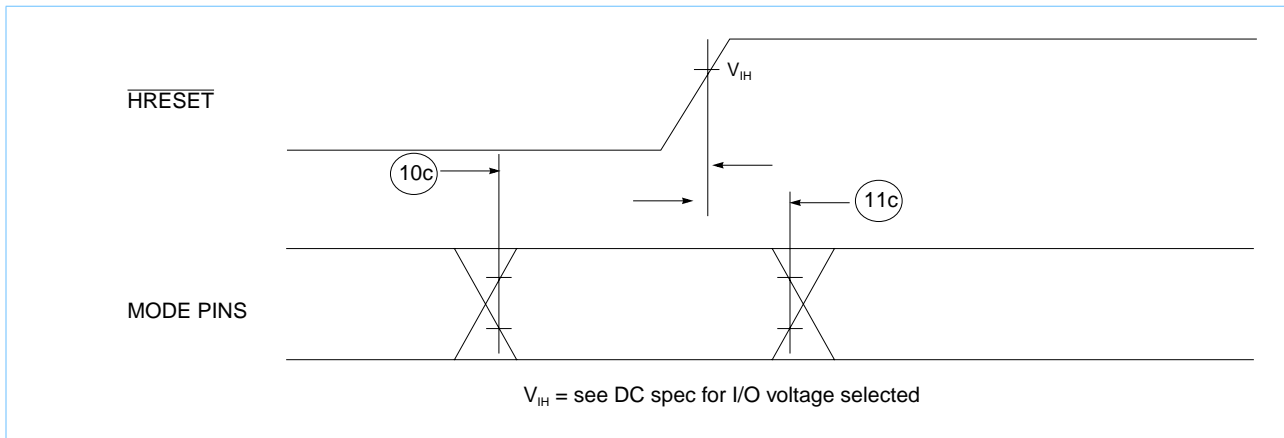

Figure 4 provides the mode select input timing diagram for the PID8p-750.

Figure 4. Mode Select Input Timing Diagram



60x Bus Output AC Specifications

The following table provides the 60x bus output AC timing specifications for the PID8p-750 as defined in Figure 5. Output timing specification for the L2 bus are provided in the Section "L2 Bus Output AC Specifications," on page 18.

60X Bus Output AC Timing Specifications¹

See Table "Recommended Operating Conditions^{1,2,3}," on page 6 for operating conditions, $C_L = 50\text{pF}^2$

Num	Characteristic	300, 333, 350, 366, 375, 400, 433, 450, 466, 500MHz		Unit	Notes
		Minimum	Maximum		
12	SYSClk to Output Driven (Output Enable Time)	0.5		ns	8
13	SYSClk to Output Valid ($\overline{\text{TS}}$, $\overline{\text{ABB}}$, $\overline{\text{ARTRY}}$, $\overline{\text{DBB}}$, and $\overline{\text{TBST}}$)	–	4.5	ns	5
14	SYSClk to all other Output Valid (all except $\overline{\text{TS}}$, $\overline{\text{ABB}}$, $\overline{\text{ARTRY}}$, $\overline{\text{DBB}}$, and $\overline{\text{TBST}}$)	–	5.0	ns	5
15	SYSClk to Output Invalid (Output Hold)	1.0		ns	3, 8, 9
16	SYSClk to Output High Impedance (all signals except $\overline{\text{ABB}}$, $\overline{\text{ARTRY}}$, and $\overline{\text{DBB}}$)	–	6.0	ns	8
17	SYSClk to $\overline{\text{ABB}}$ and $\overline{\text{DBB}}$ high impedance after precharge	–	1.0	t_{SYSClk}	4, 6, 8
18	SYSClk to $\overline{\text{ARTRY}}$ high impedance before precharge	–	5.5	ns	8
19	SYSClk to $\overline{\text{ARTRY}}$ precharge enable	$0.2 \times t_{\text{SYSClk}} + 1.0$		ns	3, 4, 7
20	Maximum delay to $\overline{\text{ARTRY}}$ precharge		1	t_{SYSClk}	4, 7
21	SYSClk to $\overline{\text{ARTRY}}$ high impedance after precharge		2	t_{SYSClk}	4, 7, 8

Note:

1. All output specifications are measured from the midpoint voltage of the rising edge of SYSClk to the midpoint voltage of the signal in question. Both input and output timings are measured at the pin. Midpoint voltage (VM) is 1.4v for OVdd in 3.3v mode and OVDD/2 for all other I/O modes.
2. All maximum timing specifications assume $C_L = 50\text{pF}$.
3. This minimum parameter assumes $CL = 0\text{pF}$.
4. t_{SYSClk} is the period of the external bus clock (SYSClk) in nanoseconds (ns). The numbers given in the table must be multiplied by the period of SYSClk to compute the actual time duration of the parameter in question.
5. Output signal transitions from GND to 2.0V or OVDD to 0.8V.
6. Nominal precharge width for $\overline{\text{ABB}}$ and $\overline{\text{DBB}}$ is $0.5 t_{\text{SYSClk}}$.
7. Nominal precharge width for $\overline{\text{ARTRY}}$ is $1.0 t_{\text{SYSClk}}$.
8. Guaranteed by design and characterization, and not tested.
9. L2_TSTCLK should be tied to OVDD.

Figure 5 provides the output timing diagram for the PID8p-750.

Figure 5. Output Timing Diagram

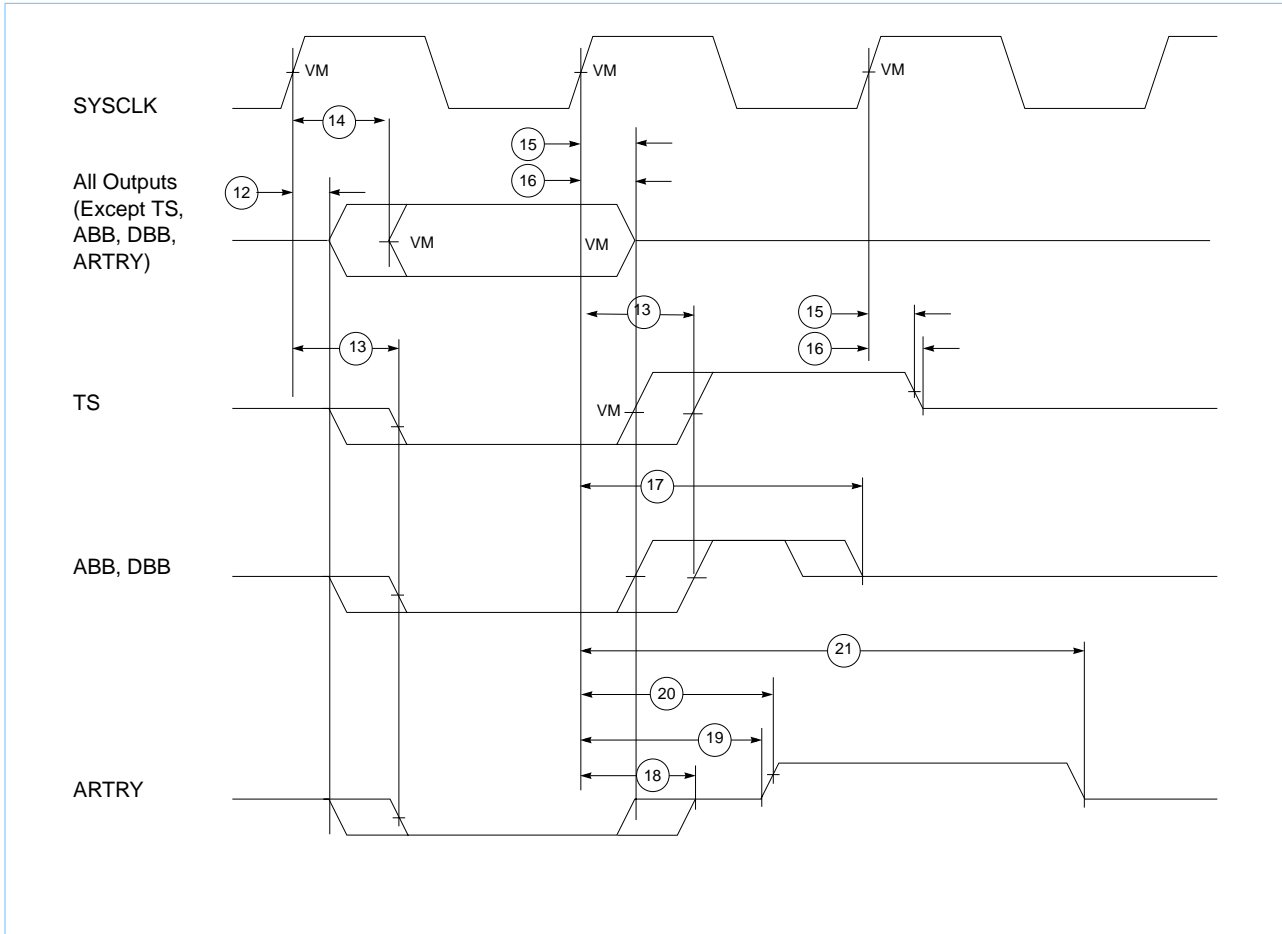

L2 Clock AC Specifications

The following table provides the L2CLK output AC timing specifications as defined in Figure 6.

L2CLK Output AC Timing Specifications

See Table “Recommended Operating Conditions^{1,2,3},” on page 6, for operating conditions.

Num	Characteristic	Min	Max	Unit	Notes
	L2CLK frequency	80	250	MHz	1,5
22	L2CLK cycle time	4.0	12.5	ns	
23	L2CLK duty cycle	50		%	2
	L2CLK jitter		±150	ps	3,6
	Internal DLL-relock time	640	—	L2CLK	4

Note:

1. L2CLK outputs are L2CLKOUTA, L2CLKOUTB and L2SYNC_OUT pins. The L2CLK frequency to core frequency settings must be chosen such that the resulting L2CLK frequency and core frequency do not exceed their respective maximum or minimum operating frequencies. L2CLKOUTA and L2CLKOUTB must have equal loading.
2. The nominal duty cycle of the L2CLK is 50% measured at midpoint voltage.
3. The total input jitter (short term and long term combined) must be under ± 150ps.
4. The DLL re-lock time is specified in terms of L2CLKs. The number in the table must be multiplied by the period of L2CLK to compute the actual time duration in nanoseconds. Re-lock timing is guaranteed by design and characterization, and is not tested.
5. The L2CR [L2SL] bit should be set for L2CLK frequencies less than 110MHz.
6. Guaranteed by design and characterization, and not tested.

The L2CLK_OUT timing diagram is shown in Figure 6.

Figure 6. L2CLK_OUT Output Timing Diagram

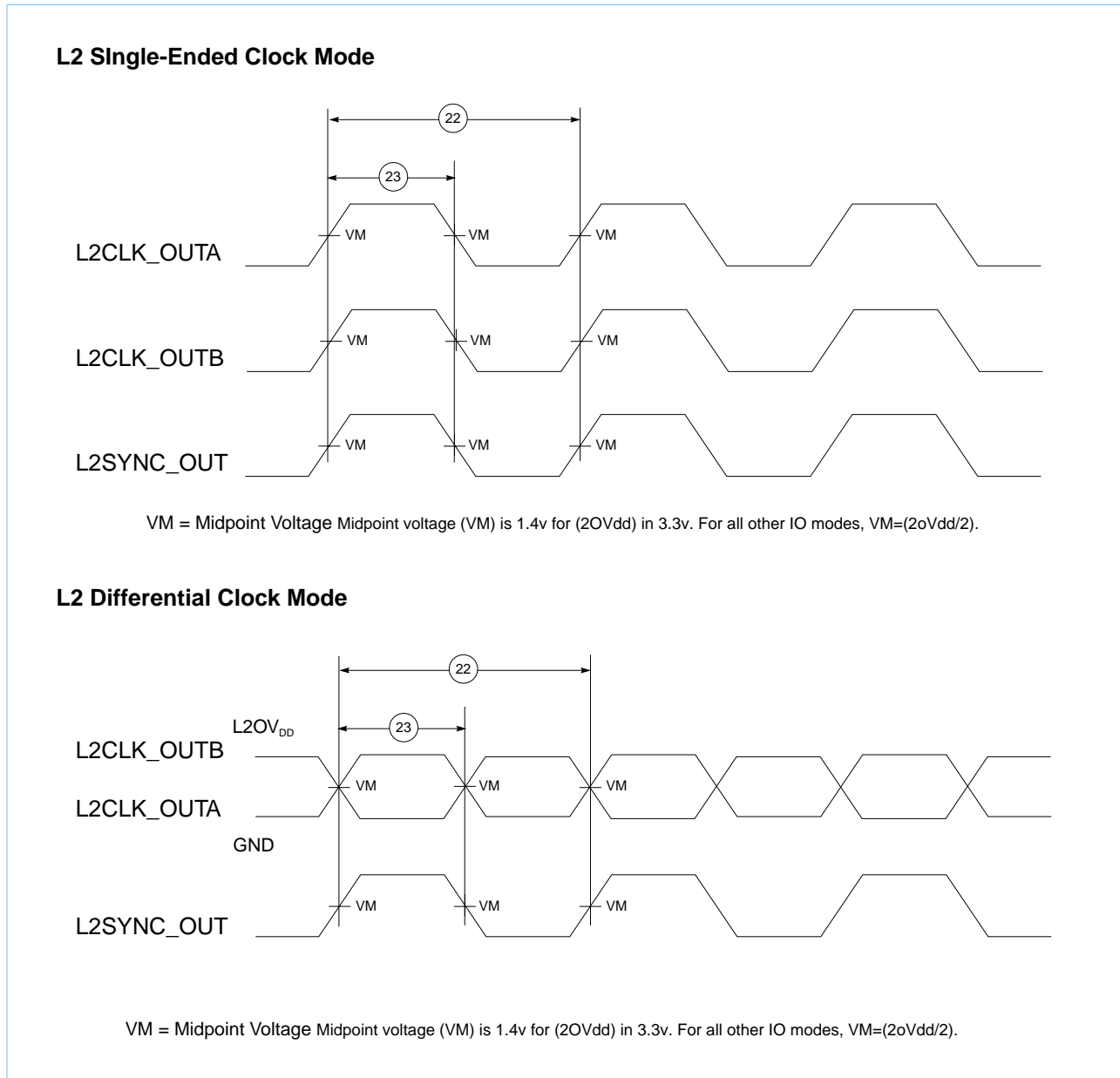

L2 Bus Input AC Specifications

The L2 bus input interface AC timing specifications are found in the following table.

L2 Bus Input Interface AC Timing Specifications

See Table “Recommended Operating Conditions1,2,3,” on page 6, for operating conditions.

Num	Characteristic	Min	Max	Unit	Notes
29,30	L2SYNC_IN rise and fall time	—	1.0	ns	2,3
24	Data and parity input setup to L2SYNC_IN; processor core at or below 375 MHz	1.5	—	ns	1
24	Data and parity input setup to L2SYNC_IN; processor core at 400 MHz	1.4	—	ns	1
24	Data and parity input setup to L2SYNC_IN; processor core at 433, 450MHz	1.1	—	ns	1
24	Data and parity input setup to L2SYNC_IN; processor core at 466, 500MHz	1.0	—	ns	1
25	L2SYNC_IN to data and parity input hold	0.5	—	ns	1

Note:

1. All input specifications are measured from the midpoint voltage of the signal in question to the midpoint voltage of the rising edge of the input L2SYNC_IN. Input timings are measured at the pins (see Figure 7). Midpoint voltage (VM) is 1.4v for (2OVdd) in 3.3v and (2OVdd/2) for all other IO modes .
2. Rise and fall times for the L2SYNC_IN input are measured from 0.5 to 1.5v.
3. Guaranteed by design and characterization, and not tested.

Figure 7 shows the L2 bus input timing diagrams for the PID8p-750.

Figure 7. L2 Bus Input Timing Diagrams

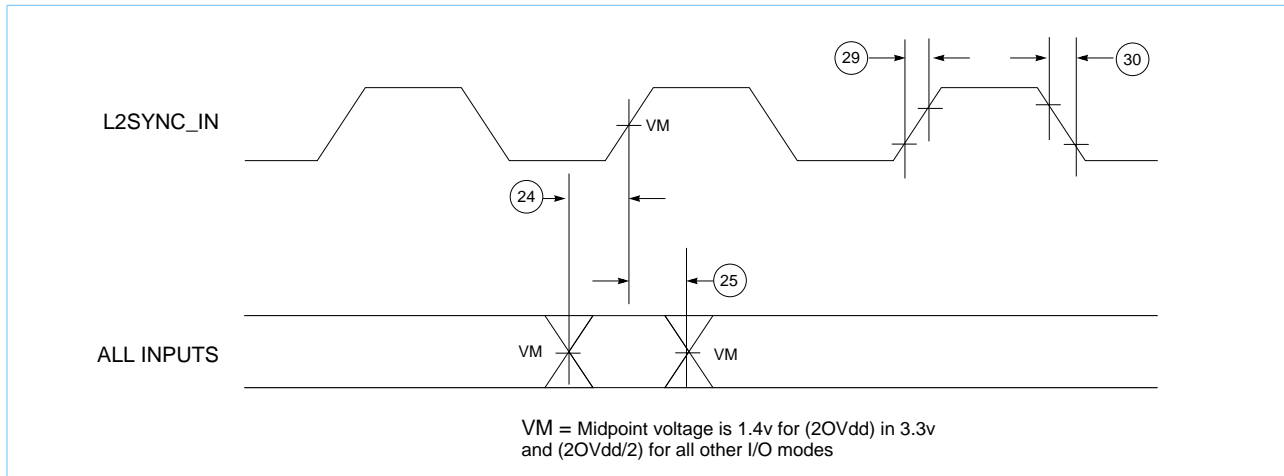

L2 Bus Output AC Specifications

The following table provides the L2 bus output interface AC timing specifications for the PID8p-750 as defined in Figure 8.

L2 Bus Output Interface AC Timing Specifications¹

See Table "Recommended Operating Conditions^{1,2,3}," on page 6 for operating conditions, $C_L = 20\text{pF}$ ³

Num	Characteristic	L2CR[14-15] is equivalent to:								Unit	Notes
		00 ²		01		10		11			
		Min	Max	Min	Max	Min	Max	Min	Max		
26	L2SYNC_IN to output valid - processor cores at or below 375 MHz	—	3.2	—	3.7	—	Rsv ⁵	—	Rsv ⁵	ns	
26	L2SYNC_IN to output valid - processor core at 400MHz	—	3.0	—	3.5	—	Rsv ⁵	—	Rsv ⁵	ns	
26	L2SYNC_IN to output valid - processor core at 433, 450MHz	—	2.6	—	3.1	—	Rsv ⁵	—	Rsv ⁵	ns	
26	L2SYNC_IN to output valid - processor core at 466 and 500MHz	—	2.4	—	2.9	—	Rsv ⁵	—	Rsv ⁵	ns	
27	L2SYNC_IN to output hold	0.5	—	1.0	—	Rsv ⁵	—	Rsv ⁵	—	ns	4,6
28	L2SYNC_IN to high impedance	—	3.5	—	4.0	—	Rsv ⁵	—	Rsv ⁵	ns	6

Note:

- All outputs are measured from the midpoint voltage of the rising edge of L2SYNC_IN to the midpoint voltage of the signal in question. The output timings are measured at the pins. Midpoint voltage (VM) is 1.4v for (2OVdd) in 3.3v and (2OVdd/2) for all other IO modes, .
- The outputs are valid for both single-ended and differential L2CLK modes. For flow-through and pipelined reg-reg synchronous burst SRAMs, L2CR[14-15] = 00 is recommended. For pipelined late-write synchronous burst SRAMs, L2CR[14-15] = 01 is recommended.
- All maximum timing specifications assume $C_L = 20\text{pF}$.
- This measurement assumes $C_L = 5\text{pF}$.
- Reserved for future use.
- Guaranteed by design and characterization, and not tested.

Figure 8 shows the L2 bus output timing diagrams for the PID8p-750.

Figure 8. L2 Bus Output Timing Diagrams

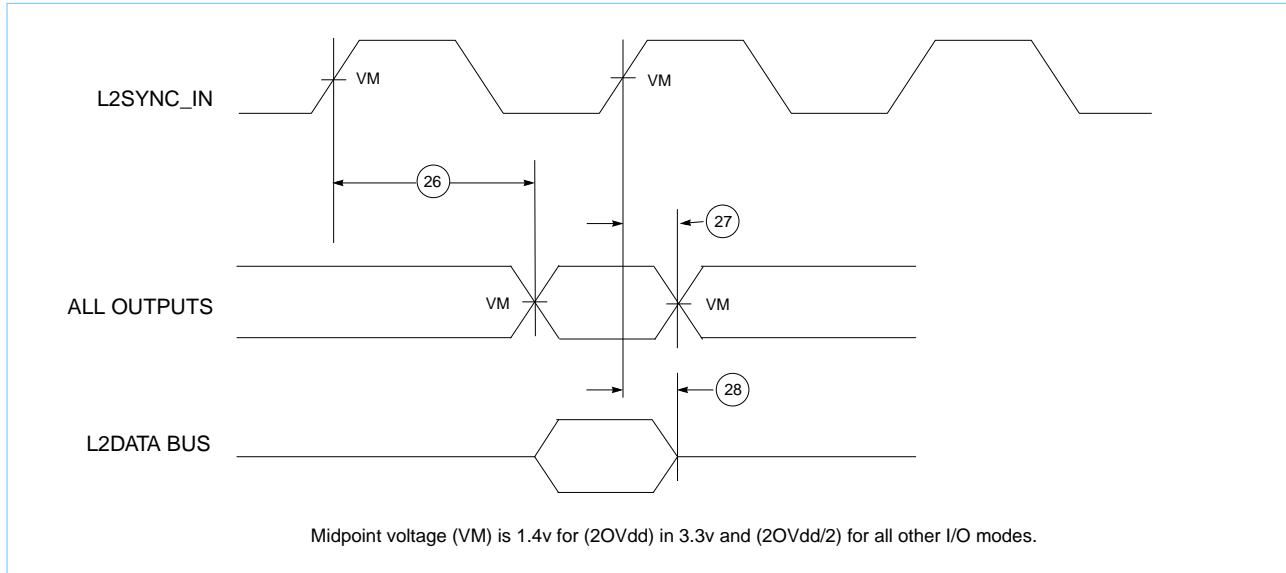

IEEE 1149.1 AC Timing Specifications

The table below provides the IEEE 1149.1 (JTAG) AC timing specifications as defined in Figure 9, Figure 10, Figure 11, and Figure 12. The five JTAG signals are; TDI, TDO, TMS, TCK, and $\overline{\text{TRST}}$.

JTAG AC Timing Specifications (Independent of SYSCLK)

See Table "Recommended Operating Conditions 1,2,3," on page 6 for operating conditions, $C_L = 50\text{pF}$.

Num	Characteristic	Min	Max	Unit	Notes
	TCK frequency of operation	0	25	MHz	
1	TCK cycle time	40	—	ns	
2	TCK clock pulse width measured at 1.4V	15	—	ns	
3	TCK rise and fall times	0	2	ns	4
4	spec obsolete, intentionally omitted				
5	$\overline{\text{TRST}}$ assert time	25	—	ns	1
6	Boundary-scan input data setup time	4	—	ns	2
7	Boundary-scan input data hold time	16	—	ns	2
8	TCK to output data valid	4	20	ns	3, 5
9	TCK to output high impedance	3	19	ns	3, 4
10	TMS, TDI data setup time	0	—	ns	
11	TMS, TDI data hold time	16	—	ns	
12	TCK to TDO data valid	2.5	12	ns	5
13	TCK to TDO high impedance	3	9	ns	4

Note:

1. $\overline{\text{TRST}}$ is an asynchronous level sensitive signal. Guaranteed by design.
2. Non-JTAG signal input timing with respect to TCK.
3. Non-JTAG signal output timing with respect to TCK.
4. Guaranteed by characterization and not tested.
5. Minimum spec guaranteed by characterization and not tested.

Figure 9 provides the JTAG clock input timing diagram.

Figure 9. JTAG Clock Input Timing Diagram

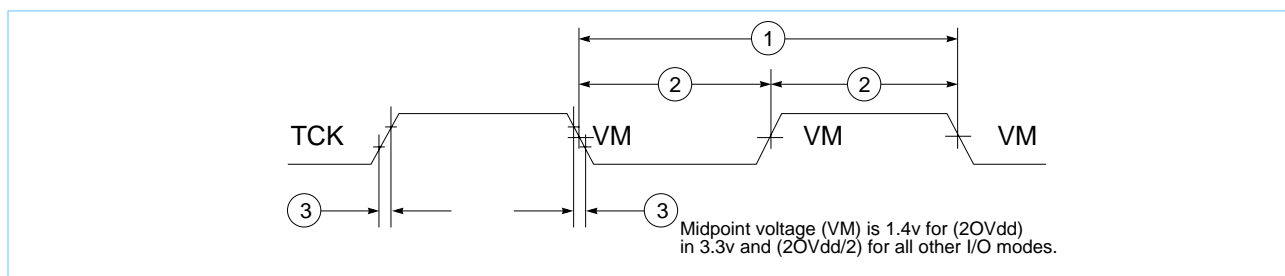

Figure 10 provides the $\overline{\text{TRST}}$ timing diagram.

Figure 10. $\overline{\text{TRST}}$ Timing Diagram

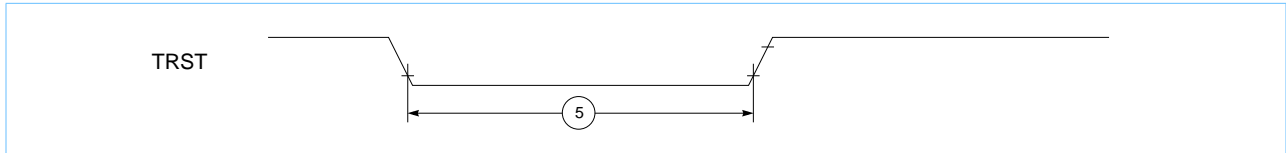

Figure 11 provides the boundary-scan timing diagram.

Figure 11. Boundary-Scan Timing Diagram

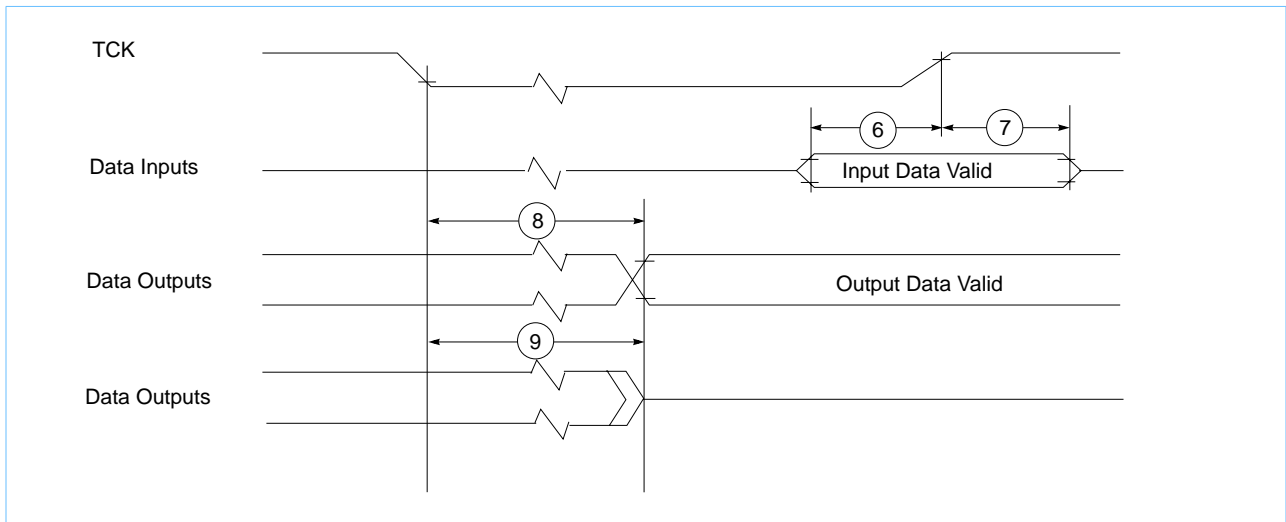
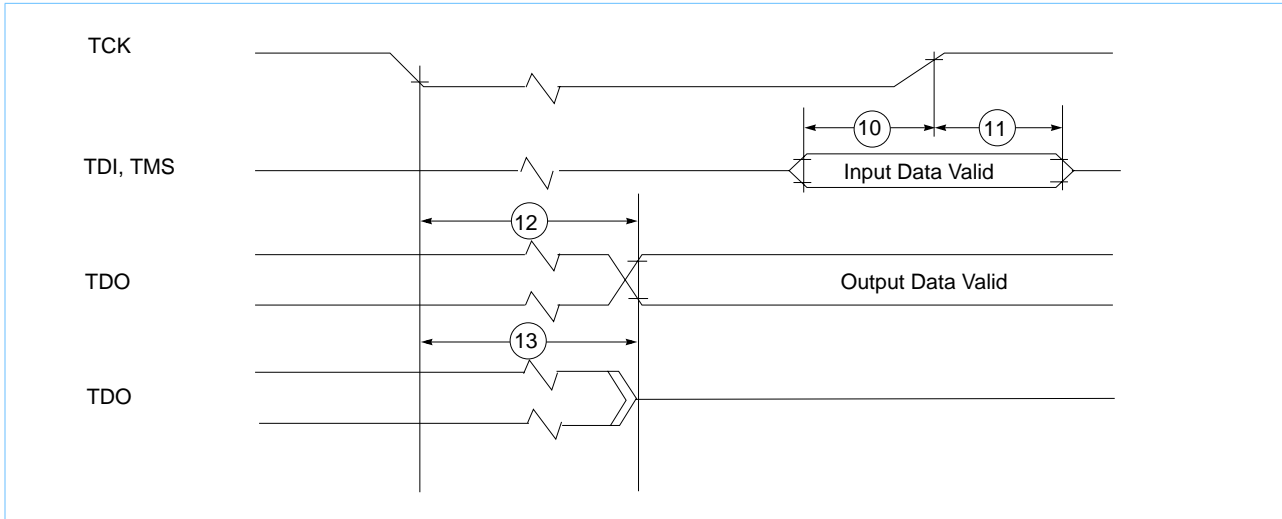

Figure 12 provides the test access port timing diagram.

Figure 12. Test Access Port Timing Diagram



PowerPC PID8p-750 Microprocessor Pin Assignments

The following sections contain the pinout diagrams for the PID8p-750 SCM. IBM offers a ceramic ball grid array 360 CBGA packages.

Figure 13 (in part A) shows the pinout of the 360 CBGA package as viewed from the top surface. Part B shows the side profile of the 360 CBGA package to indicate the direction of the top surface view.

Figure 13. Pinout of the 360 CBGA Package as Viewed from the Top Surface

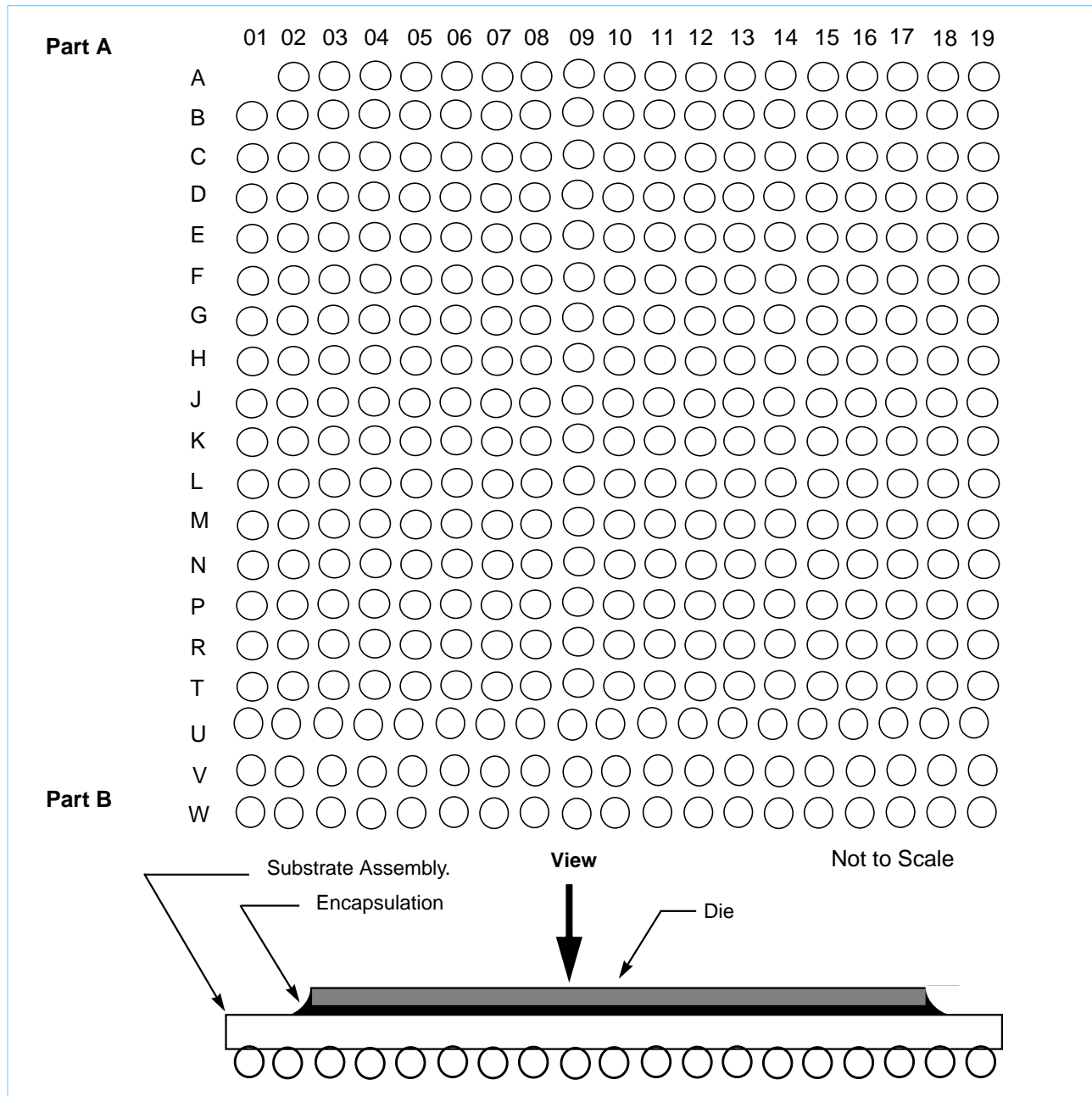

PowerPC PID8p-750 Microprocessor Pinout Listings

The following table provides the pinout listing for the 360 CBGA package (the PID8p-750).

Pinout Listing for the 360 CBGA package⁵

Signal Name	Pin Number	Active	I/O
A0-A31	A13, D2, H11, C1, B13, F2, C13, E5, D13, G7, F12, G3, G6, H2, E2, L3, G5, L4, G4, J4, H7, E1, G2, F3, J7, M3, H3, J2, J6, K3, K2, L2	High	I/O
AACK	N3	Low	Input
ABB	L7	Low	I/O
AP0-AP3 ⁸	C4, C5, C6, C7	High	I/O
ARTRY	L6	Low	I/O
AVDD ⁹	A8	—	—
BG	H1	Low	Input
BR	E7	Low	Output
CKSTP_OUT	D7	Low	Output
CI	C2	Low	Output
CKSTP_IN	B8	Low	Input
CLKOUT	E3	--	Output
DBB	K5	Low	I/O
DBDIS	G1	Low	Input
DBG	K1	Low	Input
DBWO	D1	Low	Input
DH0-DH31	W12, W11, V11, T9, W10, U9, U10, M11, M9, P8, W7, P9, W9, R10, W6, V7, V6, U8, V9, T7, U7, R7, U6, W5, U5, W4, P7, V5, V4, W3, U4, R5	High	I/O
DL0-DL31	M6, P3, N4, N5, R3, M7, T2, N6, U2, N7, P11, V13, U12, P12, T13, W13, U13, V10, W8, T11, U11, V12, V8, T1, P1, V1, U1, N1, R2, V3, U3, W2	High	I/O
DP0-DP7 ⁸	L1, P2, M2, V2, M1, N2, T3, R1	High	I/O
DRTRY	H6	Low	Input
GBL	B1	Low	I/O

Note:

1. These are test signals for factory use only and must be pulled up to OV_{DD} for normal machine operation.
2. OV_{DD} inputs supply power to the I/O drivers and V_{DD} inputs supply power to the processor core.
3. Internally tied to $L2OV_{DD}$ in the PID8p-750 360 CBGA package. This is NOT a supply pin.
4. These pins are reserved for potential future use as additional L2 address pins.
5. Pull up and pull down resistor requirements for all pins are listed in the "Pull-up / Pull-down Resistor Requirements" section on page 33
6. BVSEL selects the I/O voltage on the 60X bus. L2VSEL selects the I/O voltage on the L2 bus. Please refer to the Table "Recommended Operating Conditions^{1,2,3}," on page 6, for the use of these pins.
7. TCK must be tied high or low for normal machine operation.
8. Address and data parity signals must be tied high or low if unused in the design.
9. Starting with rev levels dd3.X, the AV_{DD} pin is no longer brought out to the package.



Pinout Listing for the 360 CBGA package⁵

Signal Name	Pin Number	Active	I/O
GND	D10, D14, D16, D4, D6, E12, E8, F4, F6, F10, F14, F16, G9, G11, H5, H8, H10, H12, H15, J9, J11, K4, K6, K8, K10, K12, K14, K16, L9, L11, M5, M8, M10, M12, M15, N9, N11, P4, P6, P10, P14, P16, R8, R12, T4, T6, T10, T14, T16	—	—
HRESET	B6	Low	Input
INT	C11	Low	Input
L1_TSTCLK ¹	F8	High	Input
L2ADDR[0-16]	L17, L18, L19, M19, K18, K17, K15, J19, J18, J17, J16, H18, H17, J14, J13, H19, G18	High	Output
L2AVDD	L13	—	—
L2CE	P17	Low	Output
L2CLKOUTA	N15	—	Output
L2CLKOUTB	L16	—	Output
L2DATA[0-63]	U14, R13, W14, W15, V15, U15, W16, V16, W17, V17, U17, W18, V18, U18, V19, U19, T18, T17, R19, R18, R17, R15, P19, P18, P13, N14, N13, N19, N17, M17, M13, M18, H13, G19, G16, G15, G14, G13, F19, F18, F13, E19, E18, E17, E15, D19, D18, D17, C18, C17, B19, B18, B17, A18, A17, A16, B16, C16, A14, A15, C15, B14, C14, E13	High	I/O
L2DP[0-7]	V14, U16, T19, N18, H14, F17, C19, B15	High	I/O
L2OVDD	D15, E14, E16, H16, J15, L15, M16, P15, R14, R16, T15, F15	—	—
L2SYNC_IN	L14	—	Input
L2SYNC_OUT	M14	—	Output
L2_TSTCLK ¹	F7	High	Input
L2WE	N16	Low	Output
L2ZZ	G17	High	Output
LSSD_MODE ¹	F9	Low	Input
MCP	B11	Low	Input
NC (No-Connect)	B3, B4, B5, W19, K9, K11 ⁴ , K19 ⁴	—	—
OVDD ²	D5, D8, D12, E4, E6, E9, E11, F5, H4, J5, L5, M4, P5, R4, R6, R9, R11, T5, T8, T12	—	—

Note:

1. These are test signals for factory use only and must be pulled up to OV_{DD} for normal machine operation.
2. OV_{DD} inputs supply power to the I/O drivers and V_{DD} inputs supply power to the processor core.
3. Internally tied to L2OV_{DD} in the PID8p-750 360 CBGA package. This is NOT a supply pin.
4. These pins are reserved for potential future use as additional L2 address pins.
5. Pull up and pull down resistor requirements for all pins are listed in the "Pull-up / Pull-down Resistor Requirements" section on page 33
6. BVSEL selects the I/O voltage on the 60X bus. L2VSEL selects the I/O voltage on the L2 bus. Please refer to the Table "Recommended Operating Conditions^{1,2,3}," on page 6, for the use of these pins.
7. TCK must be tied high or low for normal machine operation.
8. Address and data parity signals must be tied high or low if unused in the design.
9. Starting with rev levels dd3.X, the AV_{DD} pin is no longer brought out to the package.

Pinout Listing for the 360 CBGA package⁵

Signal Name	Pin Number	Active	I/O
PLL_CFG[0-3]	A4, A5, A6, A7	High	Input
QACK	B2	Low	Input
QREQ	J3	Low	Output
RSRV	D3	Low	Output
SMI	A12	Low	Input
SRESET	E10	Low	Input
SYSCLK	H9	—	Input
TA	F1	Low	Input
TBEN	A2	High	Input
TBST	A11	Low	I/O
TCK ⁷	B10	High	Input
TDI	B7	High	Input
TDO	D9	High	Output
TEA	J1	Low	Input
TLBISYNC	A3	Low	Input
TMS	C8	High	Input
TRST	A10	Low	Input
TS	K7	Low	I/O
TSIZ0-TSIZ2	A9, B9, C9	High	Output
TT0-TT4	C10, D11, B12, C12, F11	High	I/O
WT	C3	Low	Output
VDD ²	G8, G10, G12, J8, J10, J12, L8, L10, L12, N8, N10, N12	—	—
VOLTDET ³	K13	High	Output
BVSEL ⁶	W1	—	Input
L2VSEL ⁶	A19	—	Input

Note:

1. These are test signals for factory use only and must be pulled up to OV_{DD} for normal machine operation.
2. OV_{DD} inputs supply power to the I/O drivers and V_{DD} inputs supply power to the processor core.
3. Internally tied to $L2OV_{DD}$ in the PID8p-750 360 CBGA package. This is NOT a supply pin.
4. These pins are reserved for potential future use as additional L2 address pins.
5. Pull up and pull down resistor requirements for all pins are listed in the "Pull-up / Pull-down Resistor Requirements" section on page 33
6. BVSEL selects the I/O voltage on the 60X bus. L2VSEL selects the I/O voltage on the L2 bus. Please refer to the Table "Recommended Operating Conditions^{1,2,3}," on page 6, for the use of these pins.
7. TCK must be tied high or low for normal machine operation.
8. Address and data parity signals must be tied high or low if unused in the design.
9. Starting with rev levels dd3.X, the AV_{DD} pin is no longer brought out to the package.



PowerPC PID8p-750 Microprocessor Package Description

The following sections provide the package parameters and the mechanical dimensions for the PID8p-750.

Parameters for the 360 CBGA Package

The package parameters are as provided in the following list. The package type is 25 x 25mm, 360-lead ceramic ball grid array (CBGA).

Package outline	25 x 25mm
Interconnects	360 (19 x 19 ball array - 1)
Pitch	1.27mm (50mil)
Minimum module height	2.65mm
Maximum module height	3.20mm
Ball diameter	0.89mm (35mil)

Mechanical Dimensions of the 360 CBGA Package

Figure 14 provides the mechanical dimensions and bottom surface nomenclature of the 360 CBGA package.

Figure 14. Mechanical Dimensions and Bottom Surface Nomenclature of the 360 CBGA Package

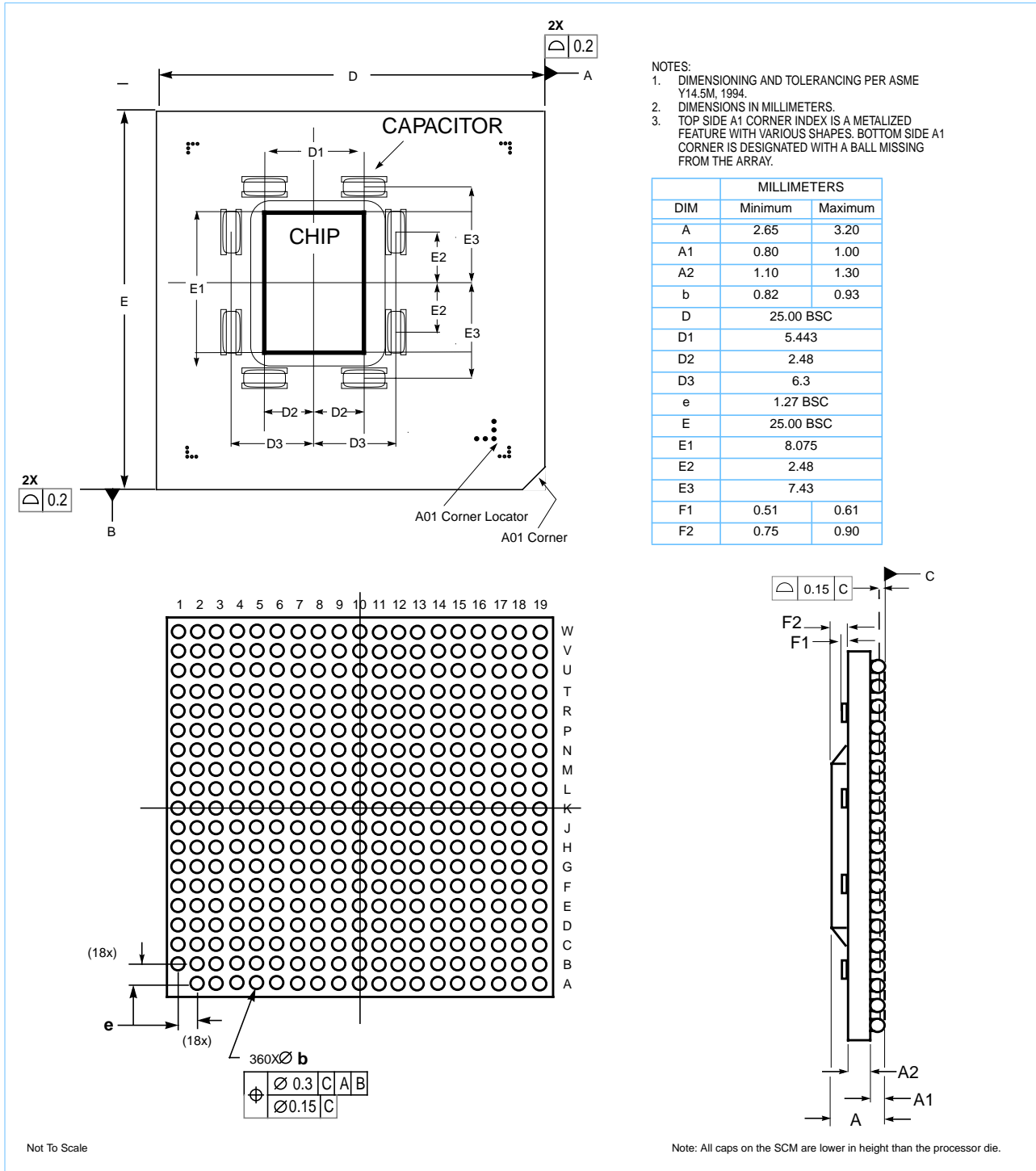
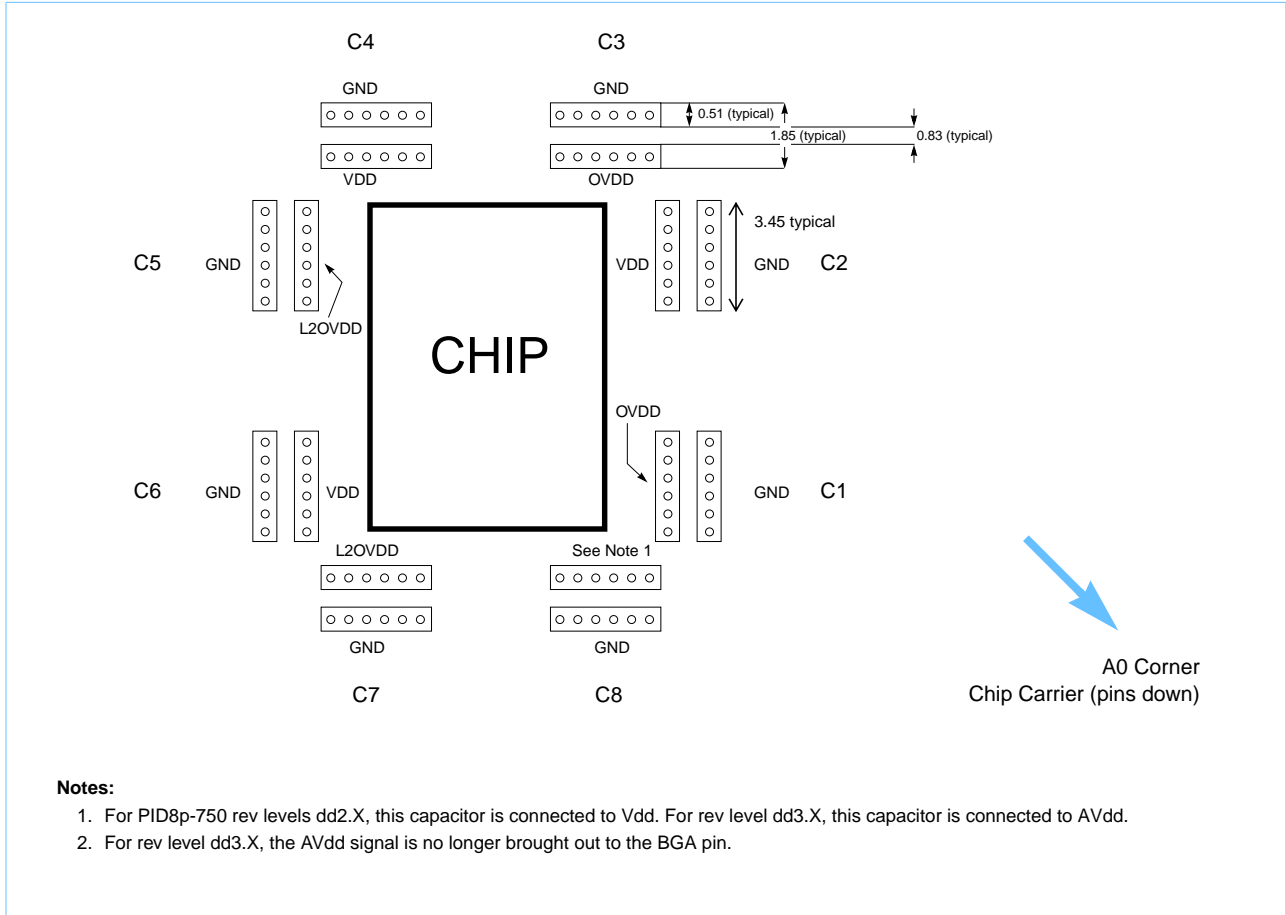

Figure 15. Decoupling Capacitors



Notes:

1. For PID8p-750 rev levels dd2.X, this capacitor is connected to Vdd. For rev level dd3.X, this capacitor is connected to AVdd.
2. For rev level dd3.X, the AVdd signal is no longer brought out to the BGA pin.

System Design Information

This section provides electrical and thermal design recommendations for successful application of the PID8p-750.

PLL Configuration

The PID8p-750 PLL is configured by the PLL_CFG[0-3] signals. For a given SYSCLK (bus) frequency, the PLL configuration signals set the internal CPU and VCO frequency of operation. The PLL configuration for the PID8p-750 is shown in the following table for nominal frequencies.

PID8p-750 Microprocessor PLL Configuration

PLL_CFG (0:3)		Processor to Bus Frequency Ratio (r)	VCO Divider (d)	Frequency Range Supported by VCO having an example range of VCO _{min} ⁷ = 400 to VCO _{max} = 1000 MHz ⁶					
bin	dec			SYSCLK		Core			
				Min = VCO _{min} /(r*d)	Max = VCO _{max} /(r*d)	Min = VCO _{min} /d	Max = VCO _{max} /d		
0000	0	Rsv ¹	n/a	n/a	n/a	n/a	n/a		
0001	1	7.5x	2	27	66	200	500		
0010	2	7x	2	29	71				
0011	3	PLL Bypass ³	n/a	n/a	n/a			n/a	n/a
0100	4	Rsv ¹	n/a	n/a	n/a	n/a	n/a		
0101	5	6.5x	2	31	77	200	500		
0110	6	10x ⁸	2	25 ²	50	200	500		
0111	7	4.5x	2	44	100 ⁵	200	500		
1000	8	3x	2	66	100 ⁵				
1001	9	5.5x	2	36	91				
1010	10	4x	2	50	100 ⁵				
1011	11	5x	2	40	100				
1100	12	8x	2	25 ²	63				
1101	13	6x	2	33	83				
1110	14	3.5x	2	57	100 ⁵				
1111	15	Off ⁴	n/a	n/a	n/a			Off	Off

Note:

- Reserved settings.
- SYSCLK min is limited by the lowest frequency that manufacturing will support, see Section , "Clock AC Specifications," for valid SYSCLK and VCO frequencies.
- In PLL-bypass mode, the SYSCLK input signal clocks the internal processor directly, the PLL is disabled, and the bus mode is set for 1:1 mode operation. This mode is intended for factory use only. **Note:** The AC timing specifications given in the document do not apply in PLL-bypass mode.
- In Clock - off mode, no clocking occurs inside the PID8p-750 regardless of the SYSCLK input.
- The SYSCLK limit is 100MHz as specified in Section "Clock AC Specifications," on page 10.
- VCO_{MAX} is specified in this table by the maximum core processor speed. See "Clock AC Specifications" on page 10. This is not the VCO limit of the technology.
- VCO_{MIN} is specified in this table by the minimum core processor speed. See "Clock AC Specifications" on page 10.
- Available on rev level DD3.x or higher

PLL Power Supply Filtering

The L2AV_{DD} power signal on the PID8p-750, provides power to the L2 cache delay-locked loop. To ensure stability of the internal clock, the power supplied to the L2AV_{DD} input signal should be filtered using a circuit similar to the one shown in Figure 16. This circuit should be placed as close as possible to the L2AV_{DD} pin to ensure it filters out as much noise as possible. For consistency in L2AV_{DD} noise measurements, the scope probe must be placed as close to the BGA pin as possible and pulse widths less than 10ns may be ignored.

Figure 16. PLL Power Supply Filter Circuit

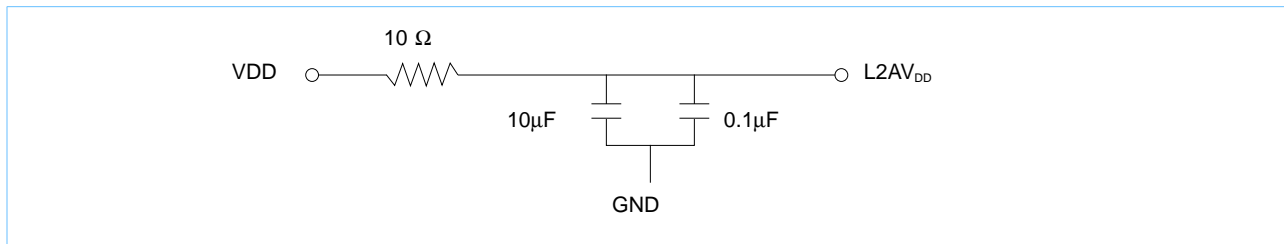

Decoupling Recommendations

Due to the PID8p-750's dynamic power management feature, large address and data buses, and high operating frequencies, the PID8p-750 can generate transient power surges and high frequency noise in its power supply, especially while driving large capacitive loads. This noise must be prevented from reaching other components in the PID8p-750 system, and the PID8p-750 itself requires a clean, tightly regulated source of power. Therefore, it is strongly recommended that the system designer place at least one decoupling capacitor with a low ESR (effective series resistance) rating at each V_{DD} and OV_{DD} pin (and L2OV_{DD} for the 360 CBGA) of the PID8p-750. It is also recommended that these decoupling capacitors receive their power from separate V_{DD}, OV_{DD} and GND power planes in the PCB, utilizing short traces to minimize inductance.

These capacitors should range in value from 220pF to 10μF to provide both high and low- frequency filtering, and should be placed as close as possible to their associated V_{DD} or OV_{DD} pins. Suggested values for the V_{DD} pins – 220pF (ceramic), 0.01μF (ceramic), and 0.1μF (ceramic). Suggested values for the OV_{DD} pins – 0.01μF (ceramic), 0.1μF (ceramic), and 10μF (tantalum). Only SMT (surface-mount technology) capacitors should be used to minimize lead inductance.

In addition, it is recommended that there be several bulk storage capacitors distributed around the PCB, feeding the V_{DD} and OV_{DD} planes, to enable quick recharging of the smaller chip capacitors. These bulk capacitors should have a low ESR (equivalent series resistance) rating to ensure the quick response time necessary. They should also be connected to the power and ground planes through two vias to minimize inductance. Suggested bulk capacitors – 100μF (AVX TPS tantalum) or 330μF (AVX TPS tantalum).

Connection Recommendations

To ensure reliable operation, it is highly recommended to connect unused inputs to an appropriate signal level. Unused active low inputs should be tied to V_{DD}. Unused active high inputs should be connected to GND. All NC (no-connect) signals must remain unconnected.

Power and ground connections must be made to all external V_{DD}, OV_{DD}, and GND, pins of the PID8p-750.

External clock routing should ensure that the rising-edge of the L2 clock is coincident at the CLK input of all SRAMs and at the L2SYNC_IN input of the PID8p-750. The L2CLKOUTA network could be used only, or the

L2CLKOUTB network could also be used depending on the loading, frequency, and number of SRAMs.

Output Buffer DC Impedance

The PID8p-750 60x and L2 I/O drivers were characterized over process, voltage, and temperature. To measure Z_0 , an external resistor is connected to the chip pad, either to OV_{DD} or GND. Then the value of such resistor is varied until the pad voltage is $OV_{DD}/2$; see Figure 17, "Driver Impedance Measurement," below.

The output impedance is actually the average of two components, the resistances of the pull-up and pull-down devices. When Data is held low, SW1 is closed (SW2 is open), and R_N is trimmed until Pad = $OV_{DD}/2$. R_N then becomes the resistance of the pull-down devices. When Data is held high, SW2 is closed (SW1 is open), and R_P is trimmed until Pad = $OV_{DD}/2$. R_P then becomes the resistance of the pull-up devices. With a properly designed driver R_P and R_N are close to each other in value, then $Z_0 = (R_P + R_N)/2$.

Figure 17. Driver Impedance Measurement

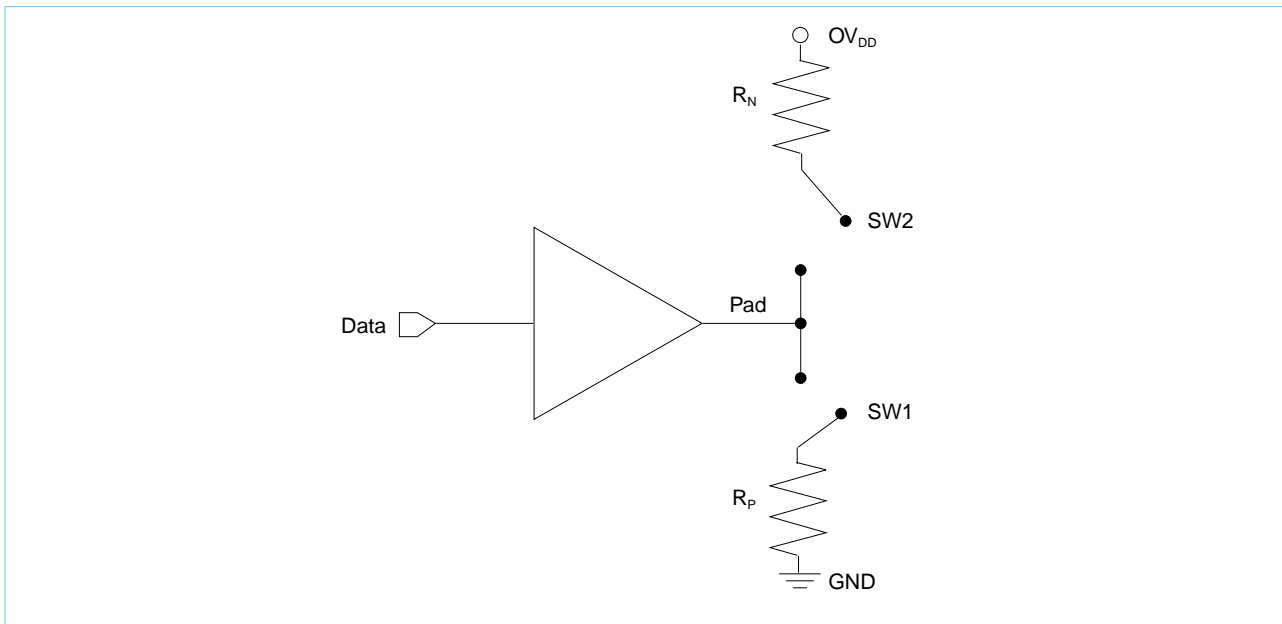

The following table summarizes the impedance a board designer would design to for a typical process. These values were derived by simulation at 65°C. As the process improves, the output impedance will be lower by several ohms than this typical value.

Impedance Characteristics

$V_{DD} = 1.9V_{DC}$, $L2OV_{DD}=OV_{DD} = 3.3V_{DC}$, $T_j = 65^\circ C$

Process	60x	L2	Symbol	Unit
Typical	43	38	Z_0	Ω

Pull-up / Pull-down Resistor Requirements

The PID8p-750 requires high-resistive (weak: 10K Ω) pull-up resistors on several control signals of the bus interface to maintain the control signals in the negated state after they have been actively negated and released by the PID8p-750 or other bus masters. These signals are: \overline{TS} , \overline{ABB} , \overline{DBB} , and \overline{ARTRY} .

In addition, the PID8p-750 has one open-drain style output that requires a pull-up resistor (weak or stronger: 4.7K Ω - 1- K Ω) if it is used by the system. This signal is: $\overline{CKSTP_OUT}$.

If address or data parity is not used by the system, and the respective parity checking is disabled through $\overline{HID0}$, the input receivers for those pins are disabled. If all parity generation is disabled through $\overline{HID0}$, then all parity checking should also be disabled through $\overline{HID0}$. It is still recommended that the unused address or data parity signals be tied high through pull up resistors to minimize noise on the package.

No pull-up resistors are normally required for the L2 interface.

Resistor Pull-up / Pull-down Requirements

Required or Recommended Actions	Signals
Strong pull-up required	$\overline{CKSTP_OUT}$
Weak pull-up required	$\overline{TLBISYNC}$, $\overline{LSSD_MODE}$, $\overline{L1_TSTCLK}$, $\overline{L2_TSTCLK}$, \overline{TS} , \overline{ABB} , \overline{DBB} , \overline{ARTRY} ,
Weak pull-up or pull-down required	TCK
Weak pull-up recommended	\overline{SRESET} , \overline{GBL} , \overline{TBST} , \overline{SMI} , \overline{INT} , \overline{MCP} , $\overline{CKSTP_IN}$
Weak pull-up recommended if pin not used	AP0-AP3, DP0-DP7
Note: See "PowerPC PID8p-750 Microprocessor Pinout Listings" section on page 24 for additional comments about these signals.	

\overline{HRESET} Requirements

\overline{HRESET} needs to be actively driven.

Thermal Management Information

This section provides thermal management information for the CBGA package for air cooled applications. Proper thermal control design is primarily dependent upon the system-level design; that is, the heat sink, air flow, and the thermal interface material. To reduce the die-junction temperature, heat sinks may be attached to the package by several methods: adhesive, spring clip to holes in the printed-circuit board or package, and mounting clip and screw assembly, see Figure 18.

Figure 18. Package Exploded Cross-Sectional View with Several Heat Sink Options

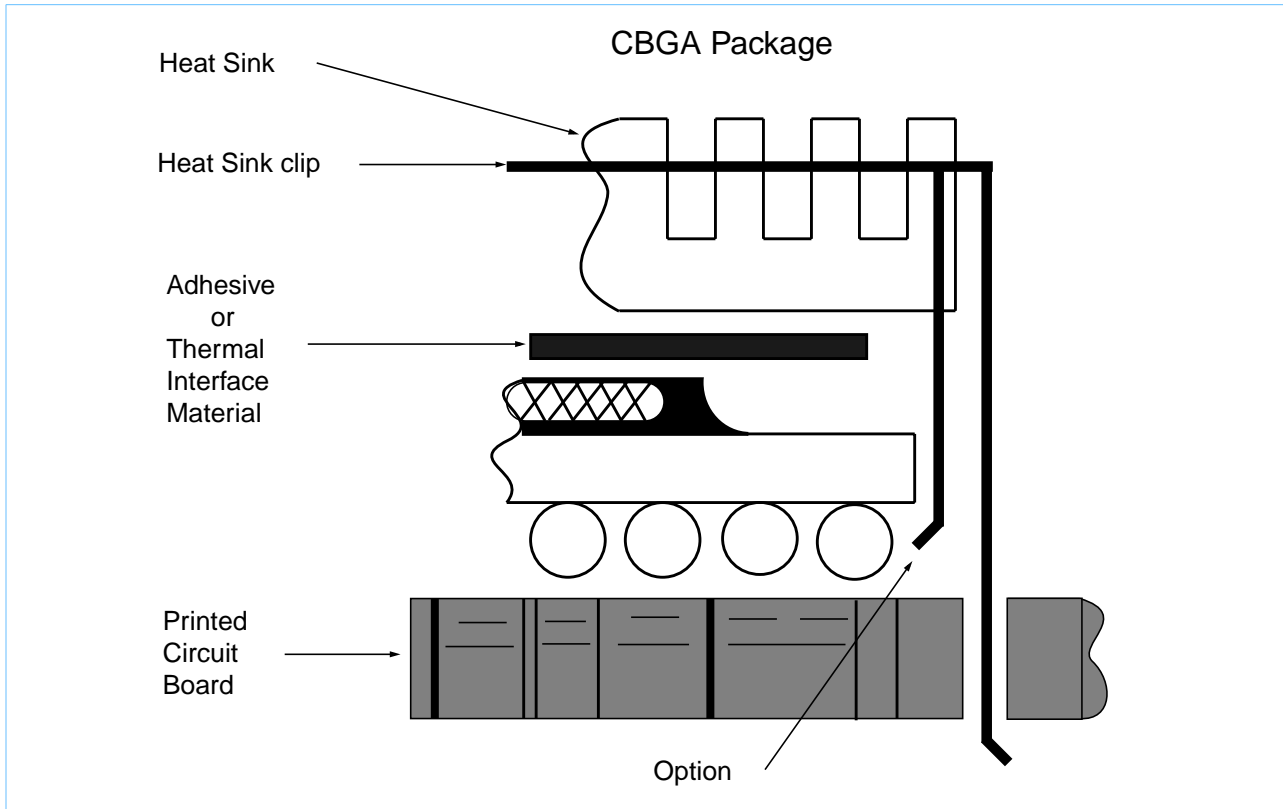

Maximum Heatsink Weight Limit for the 360 CBGA

Force	Maximum (pounds)
Dynamic Compression	10.0
Dynamic Tensile	2.5
Static Constant (Spring Force)	8.2



The board designer can choose between several types of heat sinks to place on the PID8p-750. There are several commercially-available heat sinks for the PID8p-750 provided by the following vendors:

Chip Coolers, Inc. 333 Strawberry Field Rd. Warwick, RI 02887-6979	800-227-0254 (USA/Canada) 401-739-7600
--	---

Thermalloy 2021 W. Valley View Lane P.O. Box 810839 Dallas, TX 75731	214-243-4321
---	--------------

International Electronic Research Corporation (IERC) 135 W. Magnolia Blvd. Burbank, CA 91502	818-842-7277
--	--------------

Aavid Engineering One Kool Path Laconic, NH 03247-0440	603-528-3400
--	--------------

Wakefield Engineering 60 Audubon Rd. Wakefield, MA 01880	617-245-5900
--	--------------

Ultimately, the final selection of an appropriate heat sink for the PID8p-750 depends on many factors, such as thermal performance at a given air velocity, spatial volume, mass, attachment method, assembly, and cost.

Internal Package Conduction Resistance

For the exposed-die packaging technology, shown in Table “Package Thermal Characteristics,” on page 7, the intrinsic conduction thermal resistance paths are as follows.

- Die junction-to-case thermal resistance
- Die junction-to-lead thermal resistance

Figure 19 depicts the primary heat transfer path for a package with an attached heat sink mounted to a printed-circuit board.

Figure 19. C4 Package with Heat Sink Mounted to a Printed-Circuit Board

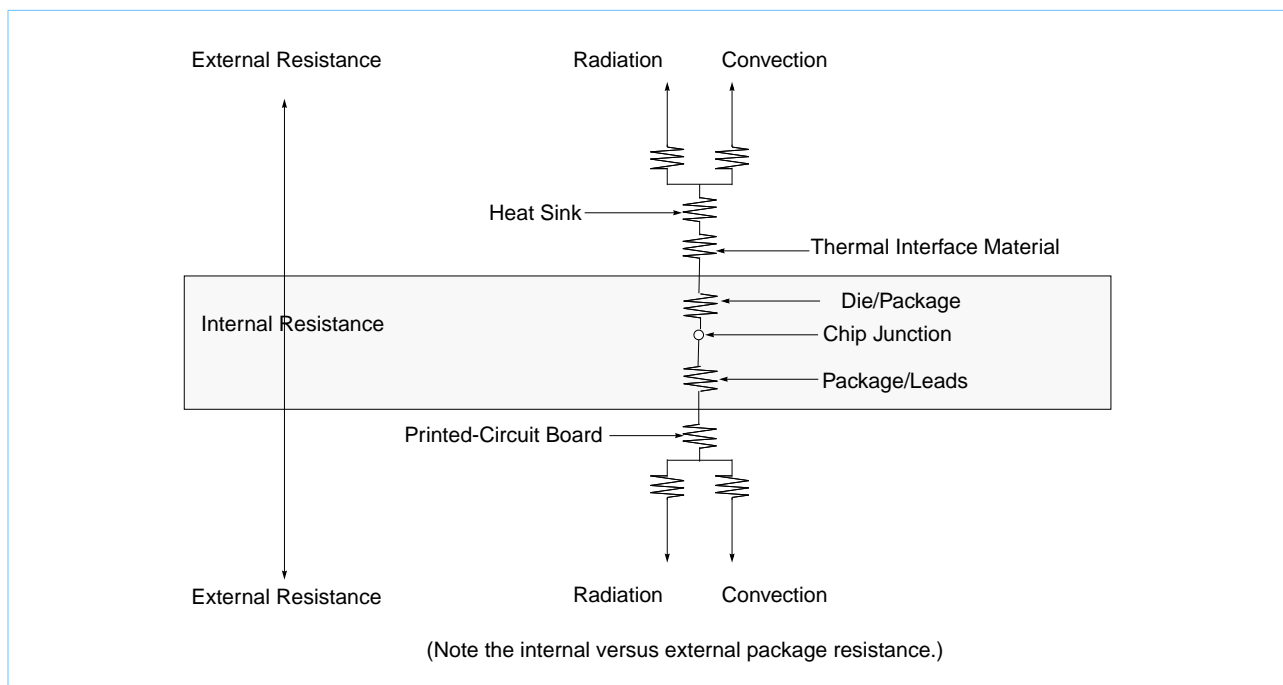

Heat generated on the active side (ball) of the chip is conducted through the silicon, then through the heat sink attach material (or thermal interface material), and finally to the heat sink; where it is removed by forced-air convection. Since the silicon thermal resistance is quite small, for a first-order analysis, the temperature drop in the silicon may be neglected. Thus, the heat sink attach material and the heat sink conduction/conductive thermal resistances are the dominant terms.

Adhesives and Thermal Interface Materials

A thermal interface material is recommended at the package lid-to-heat sink interface to minimize the thermal contact resistance. For those applications where the heat sink is attached by a spring clip mechanism, Figure 20 shows the thermal performance of three thin-sheet thermal-interface materials (silicon, graphite/oil, floeroether oil), a bare joint, and a joint with thermal grease, as a function of contact pressure. As shown, the performance of these thermal interface materials improves with increasing contact pressure. The use of thermal grease significantly reduces the interface thermal resistance. That is, the bare joint results in a thermal resistance approximately 7 times greater than the thermal grease joint.

Heat sinks are attached to the package by means of a spring clip to holes in the printed-circuit board (see Figure 18). Therefore the synthetic grease offers the best thermal performance, considering the low interface pressure. Of course, the selection of any thermal interface material depends on many factors – thermal performance requirements, manufacturability, service temperature, dielectric properties, cost, etc.

Figure 20. Thermal Performance of Select Thermal Interface Material

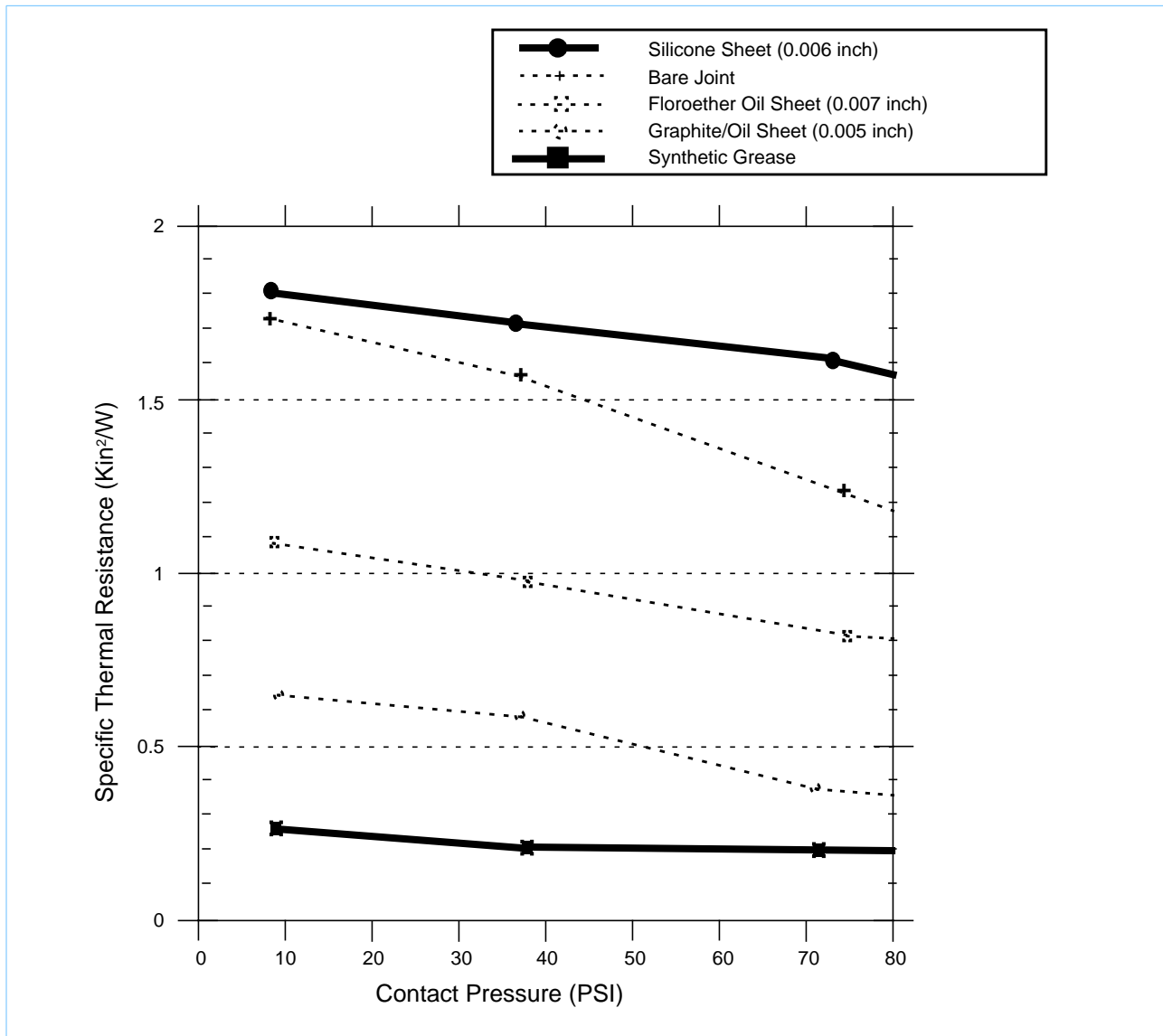

The board designer can choose between several types of thermal interfaces. Heat sink adhesive materials should be selected based upon high conductivity, yet adequate mechanical strength to meet equipment shock/vibration requirements. There are several commercially-available thermal interfaces and adhesive materials provided by the following vendors.

Dow-Corning Corporation Dow-Corning Electronic Materials P.O. Box 0997 Midland, MI 48686-0997	517-496-4000
Chomerics, Inc. 77 Dragon Court Woburn, MA 01888-4850	617-935-4850
Thermagon, Inc. 3256 West 25th Street Cleveland, OH 44109-1668	216-741-7659
Loctite Corporation 1001 Trout Brook Crossing Rocky Hill, CT 06067	860-571-5100
AI Technology (e.g. EG7655) 1425 Lower Ferry Road Trent, NJ 08618	609-882-2332

The following section provides a heat sink selection example using one of the commercially available heat sinks.

Heat Sink Selection Example

For preliminary heat sink sizing, the die-junction temperature can be expressed as follows.

$$T_J = T_A + T_R + (\theta_{JC} + \theta_{INT} + \theta_{SA}) \times P_D$$

Where:

- T_J is the die-junction temperature
- T_A is the inlet cabinet ambient temperature
- T_R is the air temperature rise within the system cabinet
- θ_{JC} is the junction-to-case thermal resistance
- θ_{INT} is the thermal resistance of the thermal interface material
- θ_{SA} is the heat sink-to-ambient thermal resistance
- P_D is the power dissipated by the device

Typical die-junction temperatures (T_J) should be maintained less than the value specified in Table "Package Thermal Characteristics," on page 7. The temperature of the air cooling the component greatly depends upon the ambient inlet air temperature and the air temperature rise within the computer cabinet. An electronic cabinet inlet-air temperature (T_A) may range from 30 to 40°C. The air temperature rise within a cabinet (T_R) may be in the range of 5 to 10°C. The thermal resistance of the interface material (θ_{INT}) is typically about 1°C/W. Assuming a T_A of 30°C, a T_R of 5°C, a CBGA package $\theta_{JC} = 0.03$, and a power dissipation (P_D) of 5.0 watts, the following expression for T_J is obtained.

$$\text{Die-junction temperature: } T_J = 30^\circ\text{C} + 5^\circ\text{C} + (0.03^\circ\text{C/W} + 1.0^\circ\text{C/W} + \theta_{SA}) \times 5\text{W}$$

For a Thermalloy heat sink #2328B, the heat sink-to-ambient thermal resistance (θ_{SA}) versus air flow velocity is shown in Figure 21.

Figure 21. Thermalloy #2328B Pin-Fin Heat Sink-to-Ambient Thermal Resistance vs. Air flow Velocity

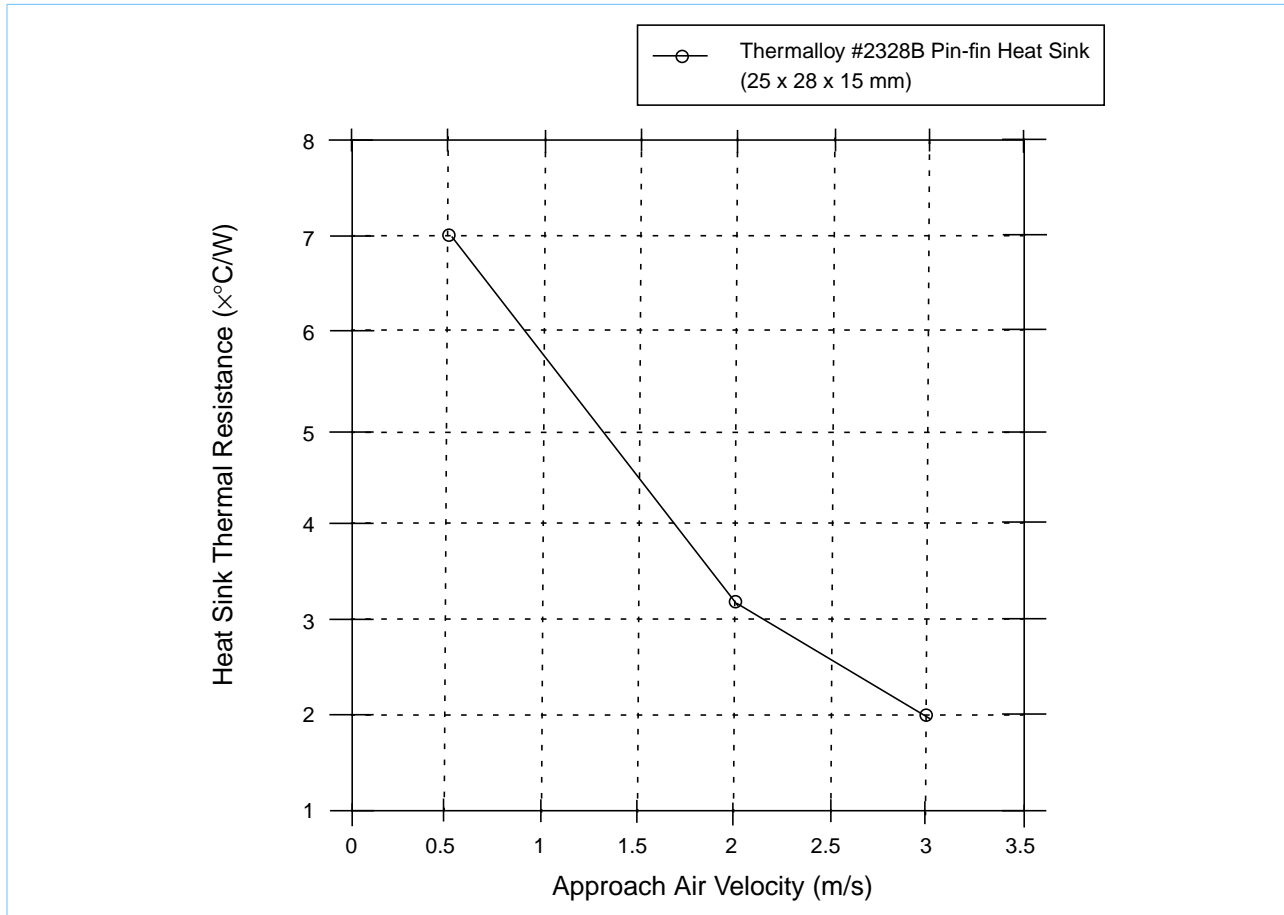

Assuming an air velocity of 0.5m/s, we have an effective θ_{SA} of 7°C/W, thus

$$T_J = 30^\circ\text{C} + 5^\circ\text{C} + (2.2^\circ\text{C/W} + 1.0^\circ\text{C/W} + 7^\circ\text{C/W}) \times 4.5\text{W},$$

resulting in a junction temperature of approximately 81°C which is well within the maximum operating temperature of the component.

Other heat sinks offered by Chip Coolers, IERC, Thermalloy, Aavid, and Wakefield Engineering offer different heat sink-to-ambient thermal resistances, and may or may not need air flow.

Though the junction-to-ambient and the heat sink-to-ambient thermal resistances are a common figure-of-merit used for comparing the thermal performance of various microelectronic packaging technologies, one should exercise caution when only using this metric in determining thermal management because no single parameter can adequately describe three-dimensional heat flow. The final chip-junction operating temperature is not only a function of the component-level thermal resistance, but the system-level design and its operating conditions. In addition to the component's power dissipation, a number of factors affect the final operating die-junction temperature. These factors might include air flow, board population (local heat flux of adjacent components), heat sink efficiency, heat sink attach, next-level interconnect technology, system air temperature rise, etc.

Ordering Information

This section provides the part numbering nomenclature for the PID8p-750. Note that the individual part numbers correspond to a maximum processor core frequency. For available frequencies, contact your local IBM sales office.

In addition to the processor frequency and bus ratio, the part numbering scheme also consists of a part modifier. The part modifier allows for the availability of future enhanced parts (that is, lower voltage, lower power, higher performance, etc.).

Each part number also contains a revision code. This refers to the die mask revision number and is specified in the part numbering scheme for identification purposes only.

Figure 22 provides the IBM part numbering nomenclature for the PID8p-750.

Figure 22. IBM Part Number Key

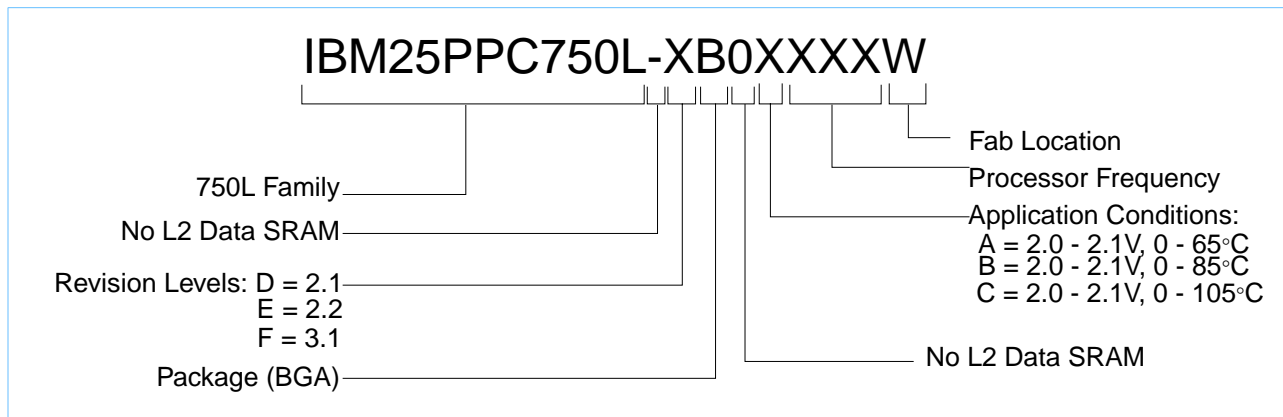

Processor Version Register (PVR)

The 750-PID8p has the following PVR values:

- 0008 8201 - 750-PID8p Rev 2.1
- 0008 8202 - 750-PID8p Rev 2.2
- 0008 8300 - 750-PID8p Rev 3.1 (Note: *dd3.1 reads 0008 8300*)



Preliminary Copy

PowerPC 750 SCM RISC Microprocessor
PID8p-750



© International Business Machines Corporation 1998

Printed in the United States of America

9/30/99

All Rights Reserved

The information contained in this document is subject to change without notice. The products described in this document are NOT intended for use in implantation or other life support applications where malfunction may result in injury or death to persons. The information contained in this document does not affect or change IBM's product specifications or warranties. Nothing in this document shall operate as an express or implied license or indemnity under the intellectual property rights of IBM or third parties. All information contained in this document was obtained in specific environments, and is presented as illustration. The results obtained in other operating environments may vary.

While the information contained herein is believed to be accurate, such information is preliminary, and should not be relied upon for accuracy or completeness, and no representations or warranties of accuracy or completeness are made.

THE INFORMATION CONTAINED IN THIS DOCUMENT IS PROVIDED ON AN "AS IS" BASIS. In no event will IBM be liable for any damages arising directly or indirectly from any use of the information contained in this document.

IBM Microelectronics Division
1580 Route 52, Bldg. 504
Hopewell Junction, NY
12533-6531

The IBM home page can be found at <http://www.ibm.com>

The IBM Microelectronics Division home page can be found at <http://www.chips.ibm.com>