

Product Specification

RoHS Compliant Long-Wavelength GBIC Transceiver

FTL-1319-3D-2.5

Product Features

- Up to 2.5Gb/s bi-directional data links
- 1310nm Fabry-Perot laser transmitter
- Optional Digital Diagnostics
- Extended operating temperature range (-10°C to +85°C)
- Compatible with 3.3 & 5V systems
- Hot-pluggable (complies with GBIC specification Rev. 5.5)
- Fully metallic enclosure for low EMI
- Low power dissipation
- RoHS compliant and Lead Free



Applications

- 1.25Gb/s 1000BASE-LX Ethernet
- 1.06 and 2.125 Gb/s Fibre Channel

Finisar's FTL-1319-3D-2.5 1310nm GBIC transceivers comply with GBIC Specification Revision 5.5¹ in all respects except where deviations are required to accommodate the higher bit rate. They are compatible with Gigabit Ethernet as specified in IEEE 802.3², Fibre Channel FC-PH, PH2, PH3³ and FC-PI-2 Rev 10.0⁴. They are RoHS compliant and lead free per Directive 2002/95/EC⁵ and Finisar Application Note AN-2038⁹.

I. Pin Out

| Pin Name | Pin # | Sequence |
|-----------------------------|--------------|-----------------|
| RX_LOS | 1 | 2 |
| GND | 2 | 2 |
| GND | 3 | 2 |
| MOD_DEF(0) | 4 | 2 |
| MOD_DEF(1) | 5 | 2 |
| MOD_DEF(2) | 6 | 2 |
| TX_DISABLE | 7 | 2 |
| GND | 8 | 2 |
| GND | 9 | 2 |
| TX_FAULT (not supported) | 10 | 2 |
| GND | 11 | 1 |
| -RX_DAT | 12 | 1 |
| +RX_DAT | 13 | 1 |
| GND | 14 | 1 |
| V _{CC} | 15 | 2 |
| V _{CC} | 16 | 2 |
| GND | 17 | 1 |
| +TX_DAT | 18 | 1 |
| -TX_DAT | 19 | 1 |
| GND | 20 | 1 |

Table 1. GBIC to host connector pin assignment

“Sequence” indicates the order in which pins make contact when the device is hot plugged. See “Table 3: Signal Definitions” in the GBIC Specification Revision 5.5.¹

II. Electrical Power Interface

Finisar FTL-1319-3D-2.5 GBICs have an extended power supply voltage range of 3.15 V to 5.5 V as described in Table 2. They are compatible with both 3.3V and 5 V systems.

| Parameter | Symbol | Min | Typ | Max | Units | Notes/Conditions |
|--------------------------|--------------------|------|--------|-----|-------|---------------------------------------|
| Supply Current | I_s | | 200 | 300 | mA | |
| Inrush Current | I_{surge} | | | 30 | mA | Hot plug, above steady state current. |
| Absolute Supply Voltage | V_{max} | -0.3 | | 6 | V | Not to be applied continuously |
| Operating Supply Voltage | V_{cc} | 3.15 | 3.3, 5 | 5.5 | V | Referenced to GND |

Table 2. Electrical power interface

III. Low Speed Signals

RX_LOS and TX_DISABLE are TTL signals as described in Table 3. MOD_DEF(1) (SCL) and MOD_DEF(2) (SDA), are open drain CMOS signals (see section VIII, “Serial Communication Protocol”). Both MOD_DEF(1) and MOD_DEF(2) must be pulled up to host_Vcc. For more detailed information, see sections 5.3.1 – 5.3.8 in the GBIC Specification Rev. 5.5¹.

| Parameter | Symbol | Min | Max | Units | Notes/Conditions |
|------------------|-----------------|----------------|----------------|-------|---|
| GBIC Output LOW | V_{OL} | 0 | 0.5 | V | 4.7k to 10k pull-up to host_Vcc, measured at host side of connector |
| GBIC Output HIGH | V_{OH} | host_Vcc - 0.5 | host_Vcc + 0.3 | V | 4.7k to 10k pull-up to host_Vcc, measured at host side of connector |
| GBIC Input LOW | V_{IL} | 0 | 0.8 | V | 4.7k to 10k pull-up to Vcc, measured at GBIC side of connector |
| GBIC Input HIGH | V_{IH} | 2 | Vcc + 0.3 | V | 4.7k to 10k pull-up to Vcc, measured at GBIC side of connector |

Table 3. Low speed signals – electronic characteristics

| Parameter | Symbol | Min | Typ | Max | Units | Notes/Conditions |
|------------------------|------------|-----|-----|------|-------|--|
| RX_LOS Assert Level | -- | -31 | | | dBm | |
| RX_LOS Deassert Level | -- | | | -20 | dBm | |
| RX_LOS Hysteresis | -- | 0.5 | | | dB | |
| RX_LOS Assert Delay | t_loss_on | | | 100 | μsec | From detection of loss of signal to assertion of RX_LOS |
| RX_LOS Negate Delay | t_loss_off | | | 100 | μsec | From detection of presence of signal to negation of RX_LOS |
| TX_DISABLE Assert Time | t_off | | | 10 | μsec | Rising edge of TX_DISABLE to fall of output signal below 10% of nominal |
| TX_DISABLE Negate Time | t_on | | | 1000 | μsec | Falling edge of TX_DISABLE to rise of output signal above 90% of nominal |
| TX_DISABLE Reset Time | t_reset | 10 | | | μsec | TX_DISABLE HIGH before TX_DISABLE set LOW |

Table 4. Low speed signal parameters

IV. High Speed Electrical Interface

All high-speed PECL signals are AC-coupled internally.

| Parameter | Symbol | Min | Typ | Max | Units | Notes/Conditions |
|---------------------|---------------------------------|-----|-----|-------------------|-------|---|
| Data Input Voltage | V _{in} | 650 | | 2000 | mV | PECL differential peak - peak |
| Data Output Voltage | V _{out} | 370 | | 2000 | mV | PECL differential peak - peak |
| PECL rise/fall | t _r , t _f | | | 160 | psec | 20%-80% differential |
| Bit Error Rate | BER | | | 10 ⁻¹² | | PRBS 2 ⁷ - 1 test data pattern |
| Tx Input Impedance | Z _{in} | | 75 | | Ohm | |
| Rx Output Impedance | Z _{out} | | 75 | | Ohm | |

Table 5. High-speed Electrical Interface

V. Optical Parameters

| Parameter | Symbol | Min | Typ | Max | Units | Notes/Conditions |
|------------------------------------|-----------------------|------|-----------------------|------|---------|--|
| TRANSMITTER CHARACTERISTICS | | | | | | |
| Transmitter Center Wavelength | λ_c | 1270 | 1310 | 1355 | nm | |
| Transmitter Spectral Width | $\Delta\lambda_{RMS}$ | | | 4 | nm | RMS |
| Transmitter Optical Output Power | P_{out} | -9 | -6 | -3 | dBm | Average power coupled into single mode fiber |
| Transmitter Extinction Ratio | ER | 9 | | | dB | |
| Transmitter Mask Margin | -- | 10 | | | % | Compliant with scaled FC ³ and 2xGE eye masks. |
| Transmitter Rise/Fall Time | tr /tf | | | 160 | ps | 20%-80% differential unfiltered |
| Total Transmitter Jitter | | | | 160 | ps | Peak to peak, filtered |
| Relative Intensity Noise | RIN | | | -120 | dB / Hz | |
| RECEIVER CHARACTERISTICS | | | | | | |
| Optical Input Wavelength | λ_{in} | 1270 | | 1355 | nm | |
| Optical Input Power | P_{in} | -18 | -22.5 @ 2.5Gb/s | -3 | dBm | BER < 10 ⁻¹² w/ PRBS 2 ⁷ - 1 test pattern @ 2.5Gb/s, 2.125Gb/s |
| Total Receiver Jitter | | | | 160 | ps | Peak to peak, filtered in loopback |

Note: Parameters are specified over temperature and voltage, at end of life unless otherwise noted.

Table 6. Optical Parameters

VI. General Specifications

| Parameter | Symbol | Min | Typ | Max | Units | Notes/Conditions |
|--------------|--------|-----|--------------------------------|--------|--------|--|
| Data Rate | BR | | 1.0625, 1.25, 2.125, 2.5 | | Gb/sec | |
| Fiber Length | L | | | 10,000 | m | 9 μ m Core Single Mode Fiber. |
| Fiber Length | L | | | 225 | m | 50 μ m 400MHz-km Fiber w/ mode conditioning patch cord for transmitter as specified in IEEE802.3z ² . |
| Fiber Length | L | | | 225 | m | 62.5 μ m 500MHz-km Fiber w/ mode conditioning patch cord for transmitter as specified in IEEE802.3z ² . |

Note 1: Distances are indicative only. Please refer to the Optical Specifications in Section V to calculate a more accurate link budget based on specific conditions in your application.

Table 7. General Specifications

VII. Environmental Specifications

| Parameter | Symbol | Min | Typ | Max | Units | Notes/Conditions |
|-------------------|------------------|-----|-----|-----|-------|--|
| Operating Temp | T _{op} | -10 | | 85 | °C | Case Temperature |
| Relative Humidity | RH | 0 | | 85 | % | Non Condensing |
| Storage Temp | T _{sto} | -40 | | 85 | °C | |
| Eye Safety | -- | | | | | CDRH and IEC-825 Class 1 Laser Product. See Note 1 |

Note 1: Complies with FDA performance standards for laser products except for deviations pursuant to Laser Notice No. 50, dated July 26, 2001.

Table 8. Environmental specifications

VIII. Serial Communication Protocol

All Finisar optical GBICs implement serial identification features described for ‘Module Definition “4”’ as outlined in Annex D of the GBIC Specification¹. These GBICs use an Atmel AT24C01A 128 byte E²PROM at address A0H. For details on interfacing with the E²PROM, see the Atmel data sheet titled “AT24C01A/02/04/08/16 2-Wire Serial CMOS E²PROM.”⁶

The FTR-1319-3D-2.5 also supports extended diagnostic features as described in Finisar Applications Note AN-2030, “Digital Diagnostic Monitoring Interface for Optical Transceivers”⁸, and additional information is available in SFF standard titled: “Digital Diagnostic Monitoring Interface for Optical Transceivers”⁷ (SFF-8472 rev9.3). A controller IC that monitors system parameters such as laser current, module temperature, transmitter power, and received power is accessible at address A2H.

I2C clock speed, digital diagnostic accuracy and digital diagnostic range can be found in the table below. Values in the table represent the worst-case values over temperature, voltage, and life.

| Parameter | Symbol | Min | Typ | Max | Units | Notes/Conditions |
|-------------------------------------|---------------------------|-------|-----|---------|-------|--|
| I ² C Clock Speed | | 0 | | 100,000 | Hz | Bus can be driven blind |
| Accuracy | | | | | | |
| Internal Transceiver Temperature | DD _{Temperature} | -3 | | +3 | °C | Measured at controller IC |
| Internal Transceiver Supply Voltage | DD _{Voltage} | -3 | | +3 | % | Measured at controller IC |
| Tx Bias Current | DD _{Bias} | -10 | | +10 | % | |
| Tx Output Power | DD _{TxPower} | -3 | | +3 | dB | 100% tested in production tested at room temp to ±2 dB |
| Received Average Power | DD _{RxPower} | -3 | | +3 | dB | 100% tested in production tested at room temp to ±2 dB |
| Range | | | | | | |
| Internal Transceiver Temperature | DD _{Temperature} | -40 | | 100 | °C | |
| Internal Transceiver Supply Voltage | DD _{Voltage} | 3.0 | | 6.0 | V | |
| Tx Bias Current | DD _{Bias} | 0 | | 80 | mA | |
| Tx Output Power | DD _{TxPower} | -13.5 | | 1 | dBm | |
| Received Average Power | DD _{RxPower} | -24 | | 1 | dBm | |

Table 9. Digital Diagnostic Accuracy and Range Limits

IX. Mechanical Specifications

Finisar GBICs are compatible with the mechanical specifications outlined in the GBIC Specification Revision 5.5, Section 6¹.

| Insertion, Extraction, and Retention Forces | | | | | | |
|---|----------------|-----|-----|-----|---------|------------------------|
| Parameter | Symbol | Min | Typ | Max | Units | Notes/Conditions |
| GBIC insertion | F _I | 0 | | 20 | Newtons | ~4.5 lbs |
| GBIC extraction | F _E | 0 | | 15 | Newtons | ~3.3 lbs |
| GBIC retention | F _R | 130 | | N/A | Newtons | Straight out ~29.3 lbs |

Table 10. Insertion, extraction, and retention forces

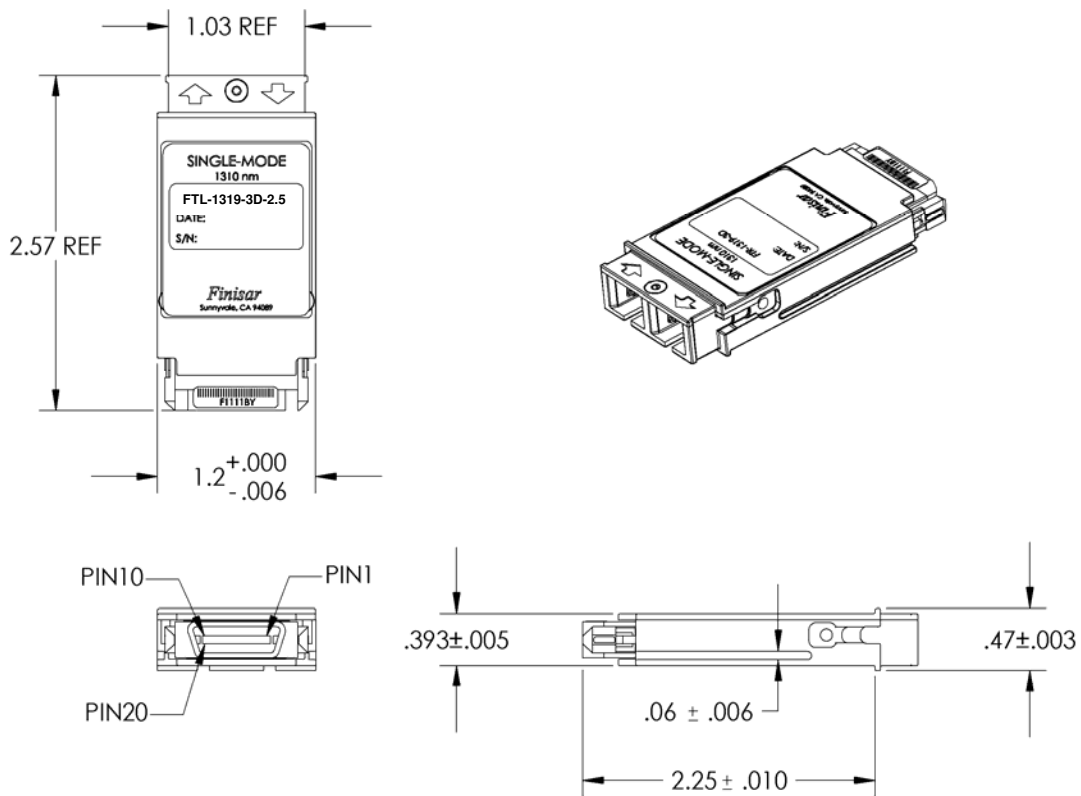

Figure 1. GBIC outline drawing

X. References

1. “Gigabit Interface Converter (GBIC) Revision 5.5”. Sun Microsystems Computer Company et. al., August 16, 1999. <http://playground.sun.com/pub/OEmod/>
2. IEEE Std 802.3. IEEE Standards Department, 2002.
3. “Fibre Channel Physical and Signaling Interface (FC-PH, FC-PH2, FC-PH3)”. American National Standard for Information Systems.
4. Fibre Channel Draft Physical Interface Specification (FC-PI-2 Rev. 10.0). American National Standard for Information Systems.
5. Directive 2002/95/EC of the European Council Parliament and of the Council, “on the restriction of the use of certain hazardous substances in electrical and electronic equipment.” January 27, 2003.
6. “AT24C01A/02/04/08/16 2-Wire Serial CMOS E²PROM”. Atmel Corporation. www.Atmel.com
7. “Digital Diagnostics Monitoring Interface for Optical Transceivers”. SFF Document Number SFF-8472, Revision 9.3.
8. “Application Note AN-2030: Digital Diagnostic Monitoring Interface for Optical Transceivers”, Finisar Corporation, April 2002.
9. “Application Note AN-2038: Finisar Implementation of RoHS Compliant Transceivers”, Finisar Corporation, March 2005.

XI. For More Information

Finisar Corporation
1389 Moffett Park Drive
Sunnyvale, CA 94089-1134
Tel. 1-408-548-1000
Fax 1-408-541-6138
sales@finisar.com
www.finisar.com