

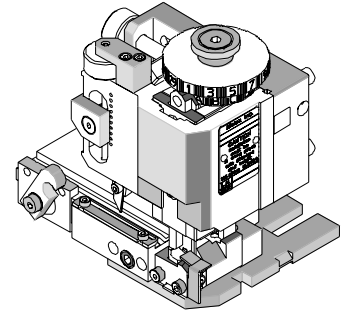

FineAdjust Applicator Specification Sheet Part No. 63862-2000



FEATURES

- Quick punch removal with the push of a button for fast and easy tooling change
- Applicator designed to industry standard mounting and shut height 135.80mm (5.346")
- Quick set-up time; plus the crimp height, track and feed adjustments can be set without removing the applicator from the press
- Fine adjustment allows users to achieve target with little effort by adjusting in increments of 0.15mm (.0006") for conductor crimp height and .063mm (.0025") for insulation height
- Independent adjustment rings allow users to quickly adjust the conductor or insulation crimp height without affecting each other
- Directly adapts to most automatic wire processing machines

SCOPE

Products: 1.27mm (.050") Pitch Ulti-Mate™ Commercial Micro D, 26-28 AWG.

Terminal Series No.	Terminal Order No.		Wire Size		Insulation Diameter		Strip Length	
			AWG	mm ²	mm	In.	mm	In.
83000	83000-9502	83000-9503	26	0.14	0.89-1.02	.035-.040	1.30-1.60	.051-.063
	83000-9547	83000-9550						
	83000-9557	83000-9558						
	83000-9559	83000-9561						
	83000-9562							
	83000-9502	83000-9503	28	0.08	0.50-1.00	.020-.039	1.30-1.60	.051-.063
	83000-9547	83000-9550						
	83000-9557	83000-9558						
	83000-9559	83000-9561						
	83000-9562							

DEFINITION OF TERMS

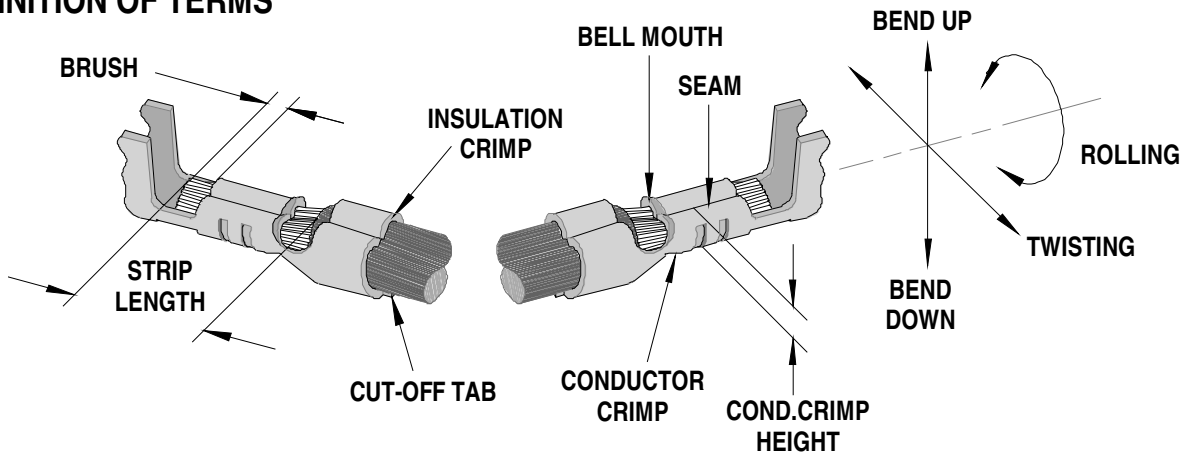

The above terminal drawing is a generic terminal representation. It is not an image of a terminal listed in the scope.

CRIMP SPECIFICATION

Terminal Series No.	Bell mouth		Cut-off Tab Maximum		Conductor Brush	
	mm	In.	mm	In.	mm	In.
83000	0.00-0.10	.000-.004	0.15	.006	0.00-0.45	.000-.018

Terminal Series No.	Bend up	Bend down	Twist	Roll	Punch Width (Ref)				Seam Seam shall not be open and no wire allowed out of the crimping area
					Conductor		Insulation		
	Degree		Degree		mm	In.	mm	In.	
83000	3	3	8	10	0.80	.031	0.90	.035	

The above specifications are guidelines to an optimum crimp.

CONDITIONS

After crimping, the conductor profile should measure the following.

Terminal Order No.	Wire Size		Crimp Height		Pull Force Minimum	
	AWG	mm ²	mm	In.	N	Lb.
83000-9502	28	0.08	0.41-0.46	.016-.018	9.8	2.20
	26	0.14	0.54-0.58	.021-.023	13.4	3.00
83000-9503	28	0.08	0.41-0.46	.016-.018	9.8	2.20
	26	0.14	0.54-0.58	.021-.023	13.4	3.00
83000-9547	28	0.08	0.41-0.46	.016-.018	9.8	2.20
	26	0.14	0.54-0.58	.021-.023	13.4	3.00
83000-9550	28	0.08	0.41-0.46	.016-.018	9.8	2.20
	26	0.14	0.54-0.58	.021-.023	13.4	3.00
83000-9557	28	0.08	0.41-0.46	.016-.018	9.8	2.20
	26	0.14	0.54-0.58	.021-.023	13.4	3.00
83000-9558	28	0.08	0.41-0.46	.016-.018	9.8	2.20
	26	0.14	0.54-0.58	.021-.023	13.4	3.00
83000-9559	28	0.08	0.41-0.46	.016-.018	9.8	2.20
	26	0.14	0.54-0.58	.021-.023	13.4	3.00
83000-9561	28	0.08	0.41-0.46	.016-.018	9.8	2.20
	26	0.14	0.54-0.58	.021-.023	13.4	3.00
83000-9562	28	0.08	0.41-0.46	.016-.018	9.8	2.20
	26	0.14	0.54-0.58	.021-.023	13.4	3.00

Pull Force should be measured with no influence from the insulation crimp.

PARTS LIST

FineAdjust Applicator 63862-2000				
Item	Order No	Engineering No.	Description	Quantity
Perishable Tooling				
	63862-2070	63862-2070	Tool Kit (All "Y" Items)	REF
1	63820-7801	63820-7801	Conductor Punch	1 Y
2	63445-0807	63445-0807	Conductor Anvil	1 Y
3	63454-0019	63454-0019	Insulation Punch	1 Y
4	63445-0906	63445-0906	Insulation Anvil	1 Y
5	63443-0003	63443-0003	Cut-Off Plunger Front	1 Y
6	63443-0012	63443-0012	Plunger Retainer Front	1 Y
Other Components (REF 622050)				
7	11-18-4083	60707-8	Front Cover	1
8	11-24-1067	4996-4	Cut-off Plunger Spring	1
9	11-40-4039	8302-5	Plunger Striker Front	1
10	63443-0009	63443-0009	Scrap Chute Front	1
11	63443-0021	63443-0021	Lower Tooling Key	1
12	63443-2423	63443-2423	Anvil Mount	1
13	63443-4025	63443-4025	Wire Stop	1
14	63443-6001	63443-6001	Rear Cover	1
Frame				
15	63800-4901	63800-4901	Top	1
16	63801-3281	63801-3281	Base	1
17	63801-4650	63801-4650	Track	1
18	63820-7820	63820-7820	Feed Cam-Special	1
Hardware				
19	N/A	N/A	M3 by 6 Long SHCS	2**
20	N/A	N/A	M4 by 6 Long SHCS	2**
21	N/A	N/A	M4 by 12 Long BHCS	2**
22	N/A	N/A	M4 by 16 Lg SHCS	1**
23	N/A	N/A	M4 by 20 Long SHCS	1**
24	N/A	N/A	M4 by 50 Long SHCS	1**
25	N/A	N/A	3MM by 6 Long Roll Pin	1**
26	N/A	N/A	#10-32 by 1/4" Long BHCS	1**
** Available from an industrial supply company such as MSC (1-800-645-7270).				

Assembly Drawing

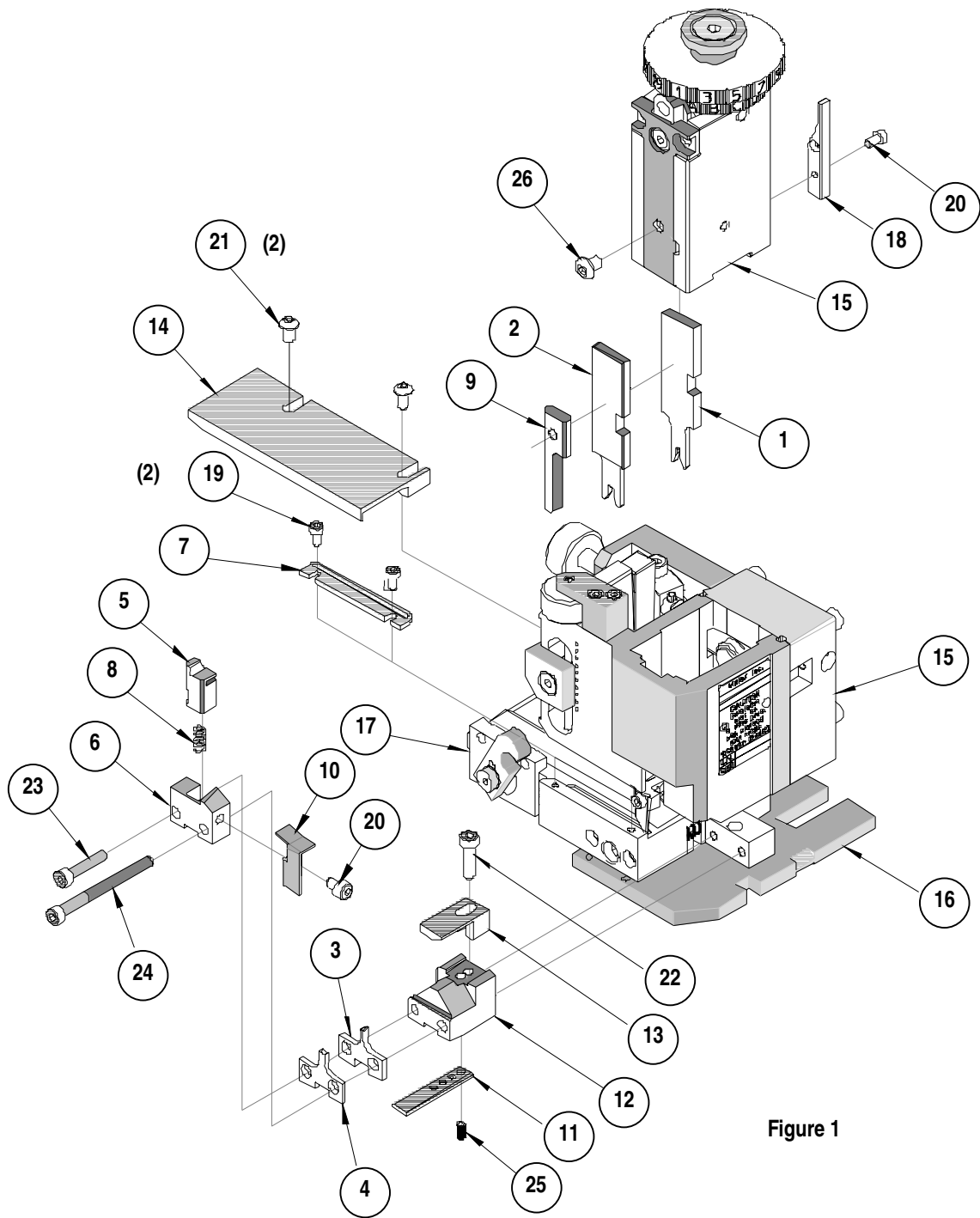

Figure 1

NOTES

1. Molex recommends an extra perishable tooling kit be maintained at your facility.
2. Verify tooling alignment by manually cycling the press and Applicator before crimping under power. Check that all screws are tight.
3. Slugs, Terminals, Dirt and Oil should be kept clear of work area.
4. Wear safety glasses at all times.
5. For recommended maintenance refer to the FineAdjust Manual.

CAUTION: This applicator should only be used in a press with a shut height of 135.8 mm (5.346"). Tooling damage could result at a lower setting.

CAUTION: To prevent injury never operate this Applicator without the guards supplied with the press or wire-processing machine in place. Reference the press or wire processing manufacturer's instruction manual.

CAUTION: Molex crimp specifications are valid only when used with Molex terminals, applicators and tooling.

Americas Headquarters
Lisle, Illinois 60532 U.S.A.
1-800-78MOLEX
amerinfo@molex.com

Far East North Headquarters
Yamato, Kanagawa, Japan
81-462-65-2324
feninfo@molex.com

Far East South Headquarters
Jurong, Singapore
65-6-268-6868
fesinfo@molex.com

European Headquarters
Munich, Germany
49-89-413092-0
eurinfo@molex.com

Corporate Headquarters
2222 Wellington Ct.
Lisle, IL 60532 U.S.A.
630-969-4550
Fax: 630-969-1352

Visit our Web site at <http://www.molex.com>