

DESCRIPTION

Demonstration circuit 832 is a dual output and dual input regulator consisting of two identical LDO linear regulators, based on the LT3028 monolithic linear regulator. Each independent input has a voltage range of 2.3V to 20V, with one output (Vout1) capable of delivering up to 500mA of output current, and the other output (Vout2) capable of delivering up to 100mA of output current. The DC supply current is typically only 50uA (for the entire IC) at no load. The LT3028 comes in either a 16-lead DFN package or TSSOP package, both of which

have an exposed pad on the bottom-side of the IC for better thermal performance. The DC832 comes installed with ceramic capacitors, because of the LT3028 ability of maintaining stability with ceramic output capacitors. There are ceramic bypass capacitors on each output for extra low noise performance. These features make the DC832 demo board an ideal circuit for use in battery-powered, hand-held applications or noise sensitive applications. **Gerber files for this circuit are available. Call the LTC Factory.**

QUICK START PROCEDURE

The DC832 is easy to set up to evaluate the performance of the LT3028. For a proper measurement equipment configuration, set up the circuit according to the diagram in Figure 1.

Please follow the procedure outlined below for proper operation.

1. Connect the input power supply to the Vin and GND terminals. Connect the loads between the Vout and GND terminals. Refer to figure 1 for the proper measurement equipment setup.
2. Before proceeding to operation, insert jumpers JP1 and JP2 into the OFF positions, jumpers JP3 and JP4 into the voltage options of choice (2.5V, 3.3V, and 5V).
3. Apply 6.5V at Vin. Measure both Vouts; they should read 0V.
4. Turn on Vout1 and Vout2 by changing jumpers JP3 and JP4 from the OFF positions to the ON positions. Both output voltages should be within a tolerance of +/- 2%.
5. Vary the input voltage from 6.5V to 20V. Both output voltages should be within +/- 3.3% tolerance.

6. Vary Vout1 load current from 0 to 500mA. Its output voltages should be within a tolerance of +/- 4%.
7. Vary Vout2 load current from 0 to 100mA. Its output voltages should be within a tolerance of +/- 4%.
8. Observe both output voltages AC-coupled; they should measure noise voltages of less than 5mVAC each. Refer to Figure 2 for proper measurement technique.
9. When finished, insert jumpers JP1 and JP2 to the OFF position(s) and disconnect the power.

Warning - If the power for the demo board is carried in long leads, the input voltage at the part could "ring", which could affect the operation of the circuit or even exceed the maximum voltage rating of the IC. To eliminate the ringing, insert a small tantalum capacitor (for instance, AVX part # TAJW106M025R) on the pads between the input power and return terminals on the bottom of the demo board. The (greater) ESR of the tantalum will dampen the (possible) ringing voltage due to the use of long input leads. On a normal, typical PCB, with short traces, the capacitor is not needed.

QUICK START GUIDE FOR DEMONSTRATION CIRCUIT 832

DUAL OUTPUT LOW NOISE LDO REGULATORS

REVISION HISTORY				
ECO	REV	DESCRIPTION	DATE	APPROVED
	1	PROTO	08/14/04	

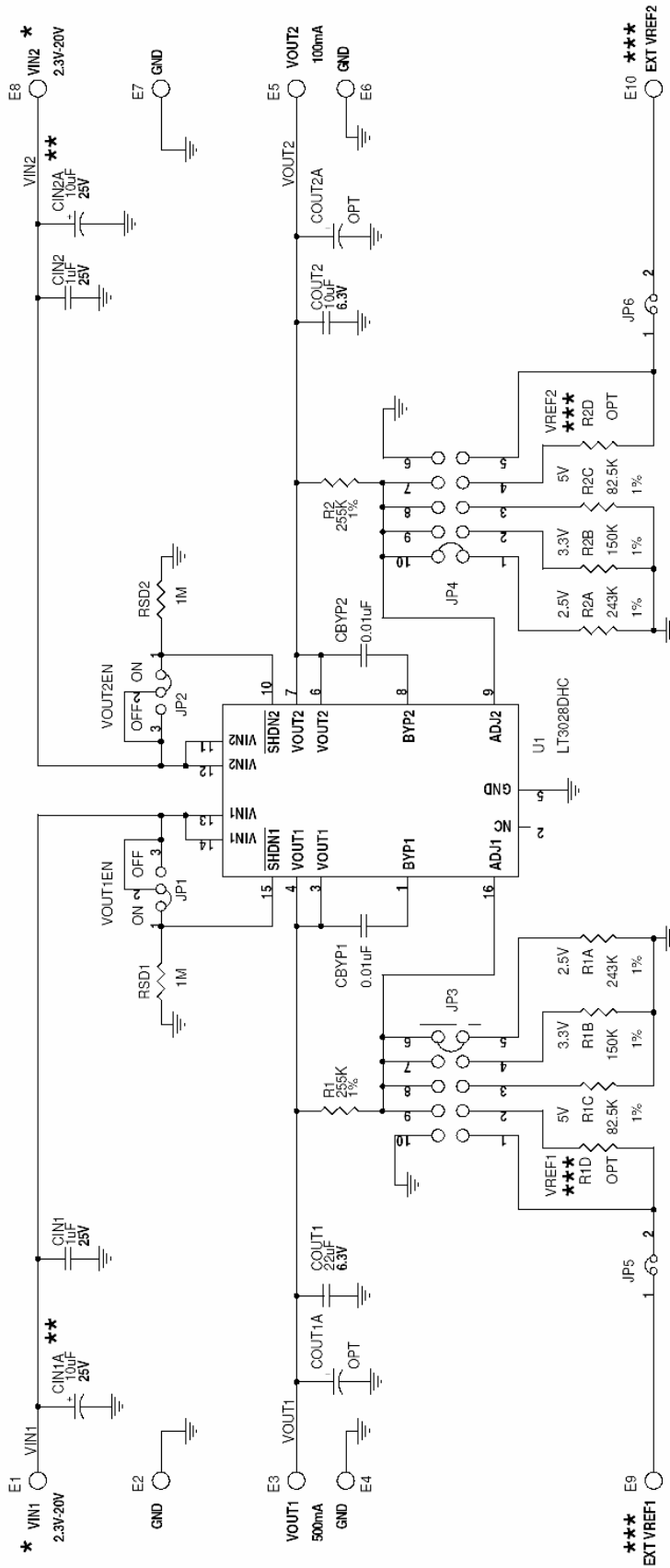

This circuit is proprietary to Linear Technology and supplied for use with Linear Technology parts.

Customer Notice: Linear Technology has made a best effort to design a circuit that meets customer-specified specifications; however, it remains the customer's responsibility to verify proper and reliable operation in the actual application. Component substitution and printed circuit board layout may significantly affect circuit performance or reliability. Contact Linear Applications Engineering for assistance.

- * 2.3V IS THE MINIMUM INPUT VOLTAGE THAT LT3028DHC WILL OPERATE AT. THE MINIMUM INPUT VOLTAGE FOR A SPECIFIC REGULATOR CIRCUIT DEPENDS ON THE OUTPUT VOLTAGE PLUS THE DROP OUT VOLTAGE.
- ** CIN1A AND CIN2A ARE OPTIONAL CAPACITORS. THEY ARE ASSEMBLED ON THE DC832A TO DAMPEN THE (POSSIBLE) RINGING VOLTAGE DUE TO THE USE OF LONG INPUT LEADS. ON A NORMAL, TYPICAL PCB, WITH SHORT TRACES, CIN1A AND CIN2A ARE NOT NEEDED.
- *** THERE ARE TWO CHOICES WHEN UTILIZING USER SELECT. THE FIRST CHOICE IS A RESISTOR TO GROUND FOR SETTING AN OUTPUT VOLTAGE BETWEEN VIN AND THE REFERENCE VOLTAGE. THIS IS THE USUAL CONFIGURATION. THE SECOND CHOICE IS A RESISTOR TO VIN OR AN EXTERNAL CONTROL VOLTAGE, WHICH ALLOWS THE OUTPUT VOLTAGE TO BE SET AT VOLTAGES BELOW VREF. THE CIRCUIT NEEDS A MINIMUM LOAD CURRENT OF 1mA TO OPERATE PROPERLY IN THIS CONFIGURATION, SO SET R1 AND/OR R2 TO 1.2K.

CONTRACT NO.		DATE	
DRAWN: m16	08/14/04	TITLE	
CHECKED:		SCH: LT3028DHC, DUAL INPUT, DUAL OUTPUT REGULATOR	
APPROVED:		SIZE	DWGNO
ENGINEER:		CAGE CODE	DC832A
DESIGNER:		SCALE: NONE	FILENAME: 832A-1.DSN
Monday, October 25, 2004		SHEET	1 OF 1



1800 McCarty Blvd.
Folsom, CA 95630
Tel: 916.242.6000
Fax: 916.242.6000