



MIC2215

Triple High PSRR, Low Noise μ Cap LDO

General Description

The MIC2215 is a high performance, triple LDO voltage regulator, with each regulator capable of providing 250mA continuous output current.

Ideal for battery operated applications, the MIC2215 offers 1% initial accuracy, extremely low dropout voltage (100mV @ 150mA), and low ground current at light load (typically 110 μ A per regulator). Equipped with a noise bypass pin and featuring very high power supply ripple rejection (PSRR) of up to 80dB, the MIC2215 provides the lowest noise and highest efficiency solution for RF applications in portable electronics such as cellular phones and wireless LAN applications.

Equipped with TTL logic-compatible enable pins, each of the regulators in the MIC2215 can be put into a zero current off mode where the supply current is much less than 1 μ A when all the regulators are disabled. The MIC2215 is a μ Cap design, which enables a stable output with small ceramic output capacitors, reducing both cost and required board space for output bypassing.

The MIC2215 is available in the miniature 16-pin, (4mm \times 4mm) MLF[®] package.

Data sheets and support documentation can be found on Micrel's web site at www.micrel.com.

Features

- Input voltage range: +2.25V to +5.5V
- 70dB PSRR
- Stable with ceramic output capacitor
- High output accuracy:
 - $\pm 1.0\%$ initial accuracy
 - $\pm 2.0\%$ over temperature
- Low dropout voltage of 100mV@150mA
- Low quiescent current: 110 μ A per regulator
- Fast turn-on time: 30 μ s
- Zero off-mode current
- Thermal shutdown protection
- Current-limit protection
- Tiny 16-pin (4mm \times 4mm) MLF[®] package

Applications

- Cellular phones
- PCs and peripherals
- Wireless LAN cards
- PDAs
- GPS

Typical Application

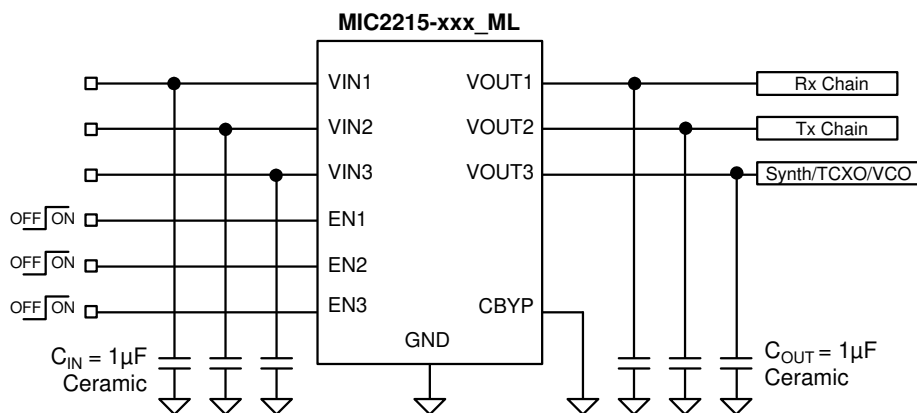

MLF and *MicroLeadFrame* are registered trademarks of Amkor Technology, Inc.

Micrel Inc. • 2180 Fortune Drive • San Jose, CA 95131 • USA • tel +1 (408) 944-0800 • fax + 1 (408) 474-1000 • <http://www.micrel.com>

Ordering Information

Part Number Standard	Part Number Pb-Free	Voltage ⁽¹⁾ (V _{o1} /V _{o2} /V _{o3})	Junction Temp. Range	Package
MIC2215-MMMBML	MIC2215-MMMYML	2.8V/2.8V/2.8V	-40° to +125°C	16-Pin 4mm x 4mm MLF [®]
MIC2215-PMMBML	MIC2215-PMMYML	3.0V/2.8V/2.8V	-40° to +125°C	16-Pin 4mm x 4mm MLF [®]
MIC2215-PPGBML	MIC2215-PPGYML	3.0V/3.0V/1.8V	-40° to +125°C	16-Pin 4mm x 4mm MLF [®]
MIC2215-PPMBML	MIC2215-PPMYML	3.0V/3.0V/2.8V	-40° to +125°C	16-Pin 4mm x 4mm MLF [®]
MIC2215-PPPBML	MIC2215-PPPYML	3.0V/3.0V/3.0V	-40° to +125°C	16-Pin 4mm x 4mm MLF [®]
MIC2215-AAABML	MIC2215-AAAYML	Adj./Adj./Adj.	-40° to +125°C	16-Pin 4mm x 4mm MLF [®]

Note:

For other voltage options, contact Micrel for details.

Voltage	Code
Adj.	A
1.5	F
1.6	W
1.8	G
1.85	D
1.9	Y
2.0	H
2.1	E
2.5	J
2.6	K
2.65	I
2.7	L
2.8	M
2.85	N
2.9	O
3.0	P
3.1	Q
3.2	R
3.3	S
3.4	T
3.5	U
3.6	V

Table 1. Voltage Codes

Pin Configuration

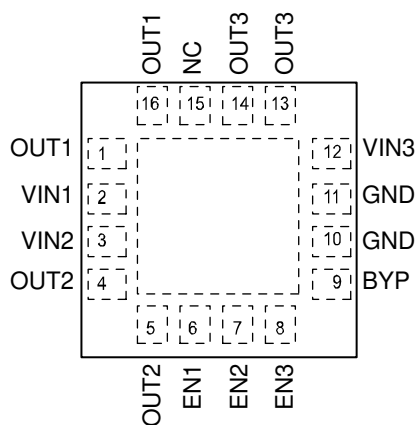

MIC2215-xxx_ML (ML)
(Fixed)

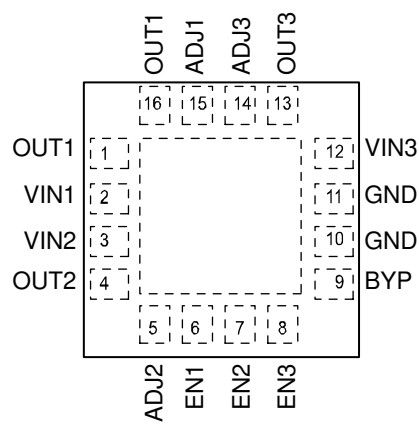

MIC2215-AAA_ML (ML)
(Adjustable)

Pin Description

Pin Number	Pin Name	Pin Function
1	VOUT1	Output voltage of regulator 1 (250mA). Connect externally to pin 16.
2	VIN1	Supply input of regulator 1 (highest input voltage required for common circuitry).
3	VIN2	Supply input of regulator 2.
4	VOUT2	Output voltage of regulator 2 (250mA). For fixed output device, connect pins 4 and 5 externally.
5	VOUT2 (Fixed)	Output voltage of regulator 2 (250mA). For fixed output device, connect pins 4 and 5 externally.
	ADJ2 (Adj.)	Adjust Input. Feedback input for regulator 2.
6	EN1	Enable input to regulator 1. Enables regulator 1 output. Active high input. High = on, low = off.
7	EN2	Enable input to regulator 2. Enables regulator 2 output. Active high input. High = on, low = off.
8	EN3	Enable input to regulator 3. Enables regulator 3 output. Active high input. High = on, low = off.
9	CBYP	Reference Bypass: Connect external 0.01 μ F to GND to reduce output noise. May be left open.
10	GND	Ground.
11	GND	Ground.
12	VIN3	Supply input of regulator 3.
13	VOUT3	Output voltage of regulator 3 (250mA). For fixed output device, connect pins 13 and 14 externally.
14	VOUT3 (Fixed)	Output voltage of regulator 3 (250mA). For fixed output device, connect pins 13 and 14 externally.
	ADJ3 (Adj.)	Adjust Input. Feedback input for regulator 3.
15	NC (Fixed)	No Connect. Not internally connected.
	ADJ1 (Adj.)	Adjust Input. Feedback input for regulator 1.
16	VOUT1	Output voltage of regulator 1 (250mA). Connect externally to pin 1.
Exposed Pad	GND	Ground.

Absolute Maximum Ratings⁽¹⁾

Supply Voltage (V_{IN})	0V to 7V
Enable Voltage (V_{EN})	0V to 7V
Power Dissipation (P_D)	Internally Limited ⁽³⁾
Junction Temperature (T_J)	-40°C to +125°C
Storage Temperature (T_S)	-65°C to +150°C
Lead Temperature (soldering, 5 sec.)	260°C
ESD Rating ⁽⁴⁾	

Operating Ratings⁽²⁾

Supply Voltage	
(V_{IN1})	2.25V to 5.5V
(V_{IN2}, V_{IN3})	2.25V to V_{IN1}
Enable Voltage (V_{EN})	0V to V_{IN1}
Junction Temperature (T_J)	-40°C to +125°C
Package Thermal Resistance	
4x4 MLF-16 (θ_{JA})	45°C/W

Electrical Characteristics⁽⁵⁾

$V_{IN1} = V_{IN2} = V_{IN3} = V_{OUT}$ (highest nominal) +1.0V; $C_{OUT} = 1.0\mu F$, $I_{OUT} = 100\mu A$; $T_J = 25^\circ C$, **bold** values indicate -40°C to +125°C; unless noted.

Parameter	Condition	Min	Typ	Max	Units
Output Voltage Accuracy		-1 -2		+1 +2	% %
Output Voltage Temp. Coefficient			40		ppm/C
Line Regulation	$V_{IN} = V_{OUT} + 1V$ to 5.5V		0.015	0.3	%/V
Load Regulation	$I_{OUT} = 100\mu A$ to 250mA		0.3	0.5	%
Dropout Voltage	$I_{OUT} = 100\mu A$		2		mV
	$I_{OUT} = 50mA$		32		mV
	$I_{OUT} = 100mA$		63		mV
	$I_{OUT} = 150mA$		100	150	mV
	$I_{OUT} = 250mA$		170	275	mV
Ground Current	$I_{OUT1} = I_{OUT2} = I_{OUT3} = 100\mu A$		280	400	μA
	$I_{OUT1} = 100\mu A$; $I_{OUT2}/I_{OUT3} = \text{off}$		110	150	μA
	$I_{OUT1} = I_{OUT2} = I_{OUT3} = 250mA$		420	550	μA
Quiescent Current	$V_{EN1} = V_{EN2} = V_{EN3} = 0V$		0.2	1	μA
Ripple Rejection	$V_{IN} = V_{OUT} + 1.0V$; $I_{OUT} = 150mA$, $f = 0.1kHz$ to 1kHz, $C_{BYP} = 0.1\mu F$		70		dB
	$V_{IN} = V_{OUT} + 0.4V$; $I_{OUT} = 150mA$, $f = 0.1kHz$ to 1kHz, $C_{BYP} = 0.1\mu F$		60		dB
	$V_{IN} = V_{OUT} + 0.2V$, $I_{OUT} = 150mA$, $f = 0.1kHz$ to 1kHz, $C_{BYP} = 0.1\mu F$		45		dB
Current Limit	$V_{OUT} = 0V$ (All regulators)	350	700		mA
Output Voltage Noise	$C_{BYP} = 0.1\mu F$, $f = 10Hz$ to 100kHz		30		μV_{RMS}
Turn-On Time	$C_{BYP} = 0.01\mu F$		30	100	μs
Enable Input					
Enable Input Voltage	Logic Low (Regulator shutdown)			0.4	V
	Logic High (Regulator enabled)	1.5			V
Enable Input Current	$V_{IL} < 0.4V$ (Regulator shutdown)		1.0		μA
	$V_{IH} > 1.5V$ (Regulator enabled)		0.01		μA

Notes:

- Exceeding the absolute maximum rating may damage the device.
- The device is not guaranteed to function outside its operating rating.
- The maximum allowable power dissipation of any T_A (ambient temperature) is $P_{D(max)} = (T_{J(max)} - T_A) \div \theta_{JA}$. Exceeding the maximum allowable power dissipation will result in excessive die temperature, and the regulator will go into thermal shutdown.
- Devices are ESD sensitive. Handling precautions recommended.
- Specification for packaged product only.

Typical Characteristics

TA = +25°C, unless otherwise noted

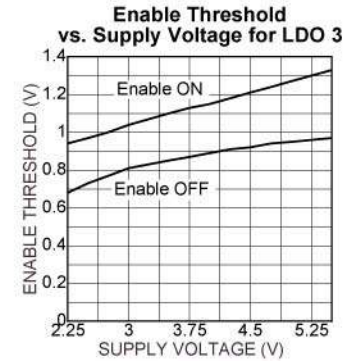
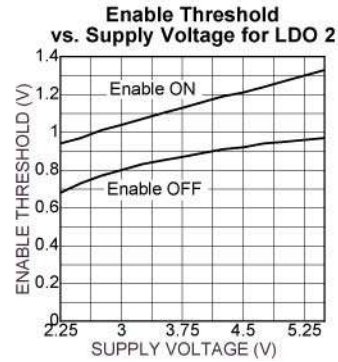
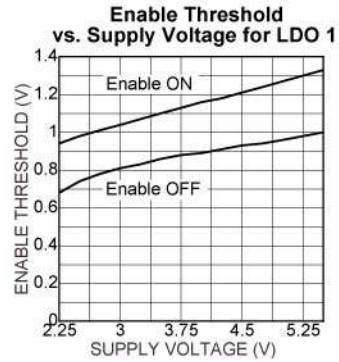
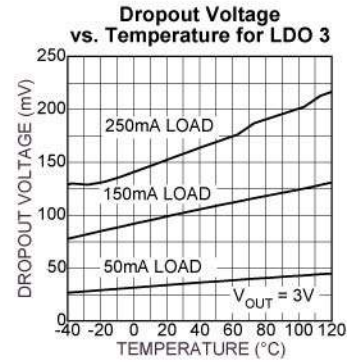
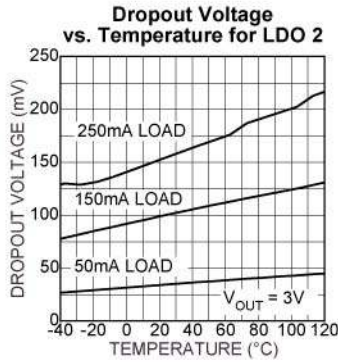
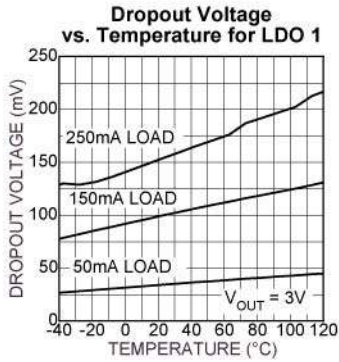
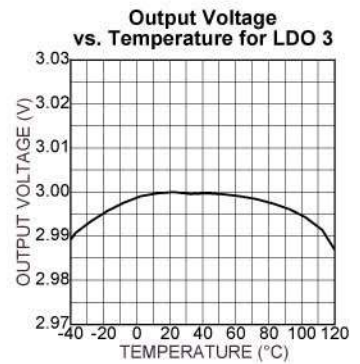
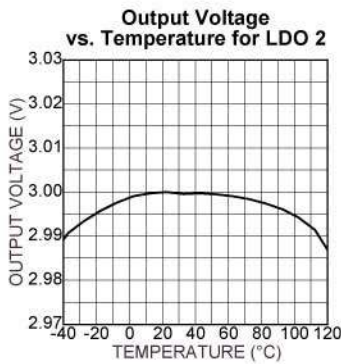
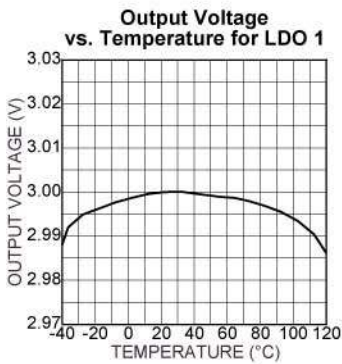
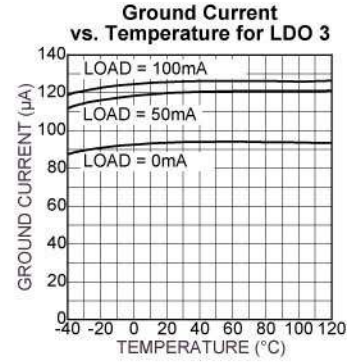
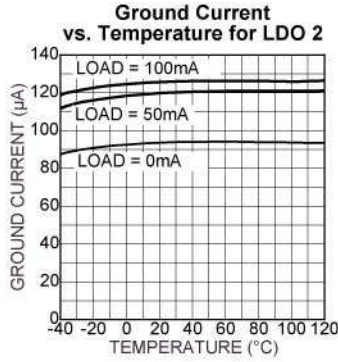
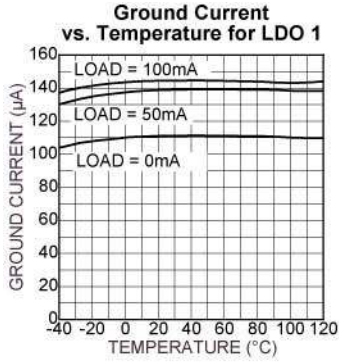

Typical Characteristics (cont.)

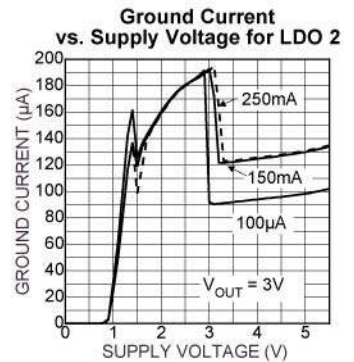
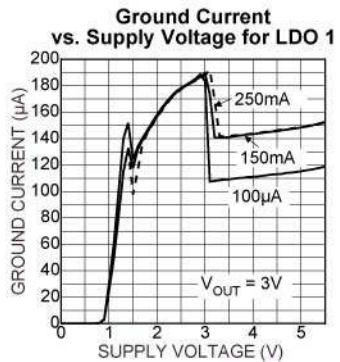
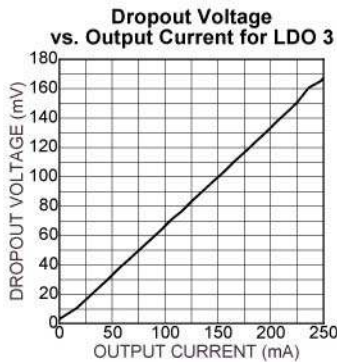
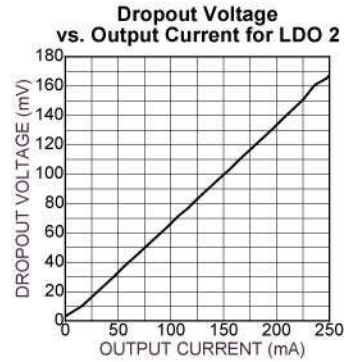
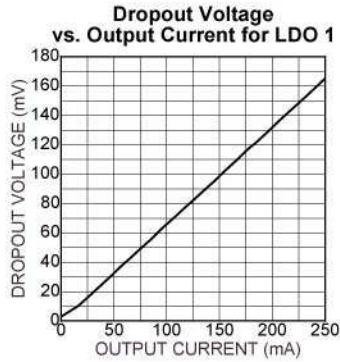
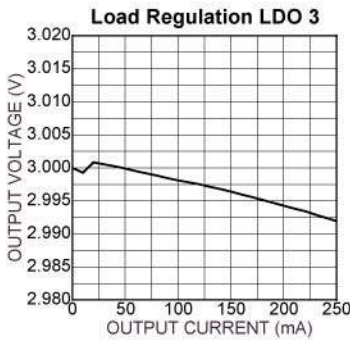
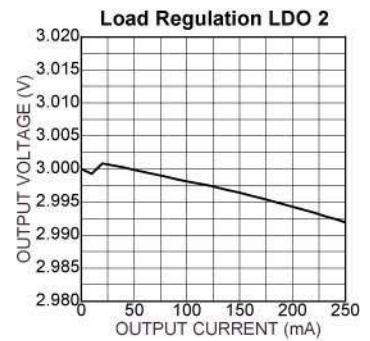
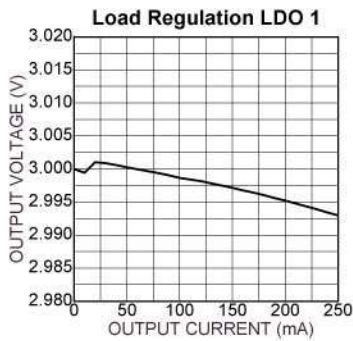
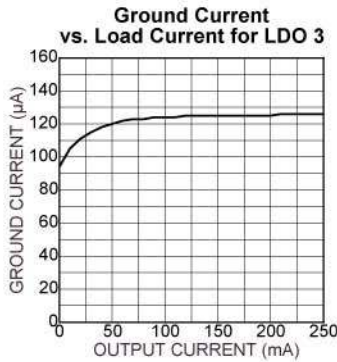
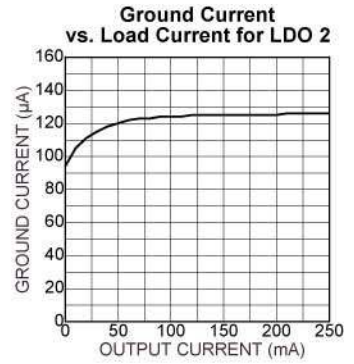
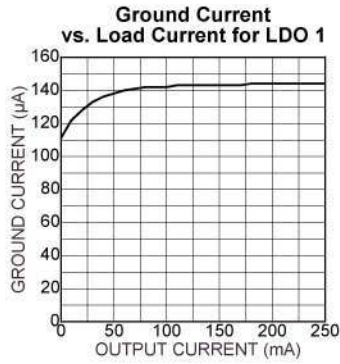
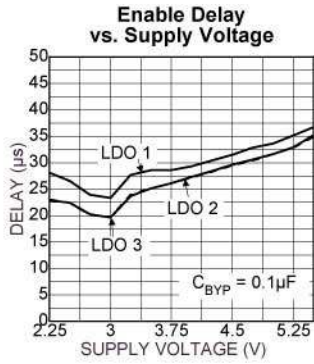

Typical Characteristics (cont.)

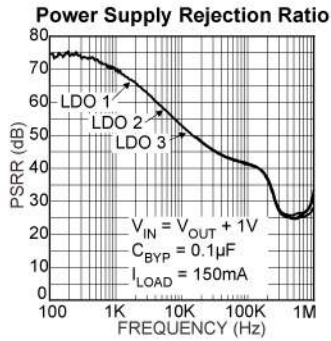
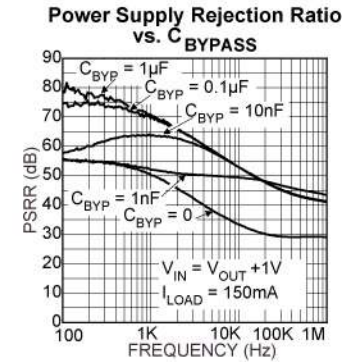
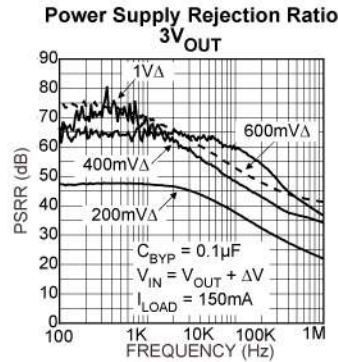
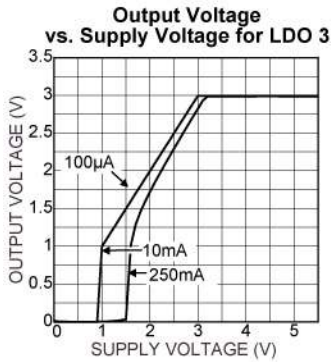
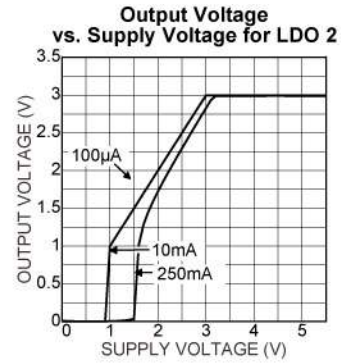
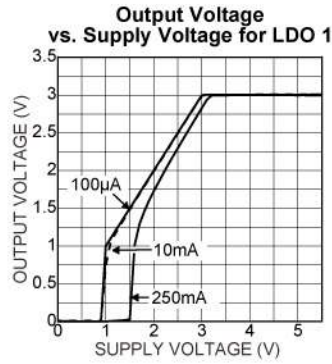
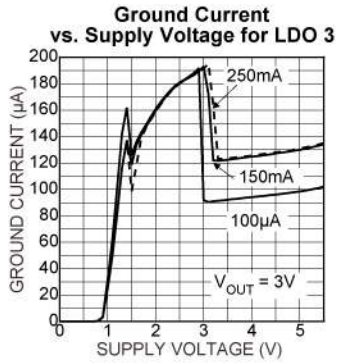

Functional Diagram

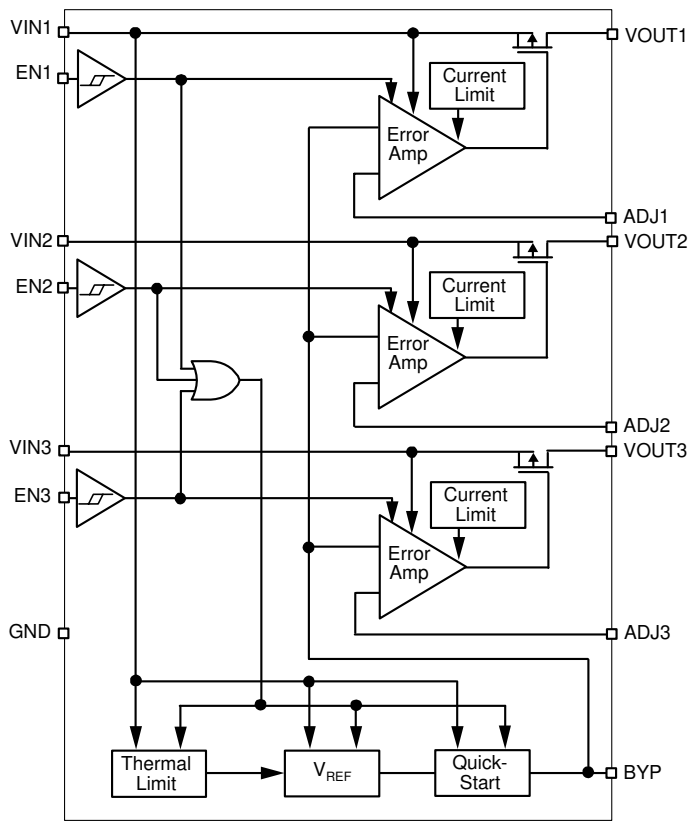

**MIC2215 Block Diagram
(Adjustable)**

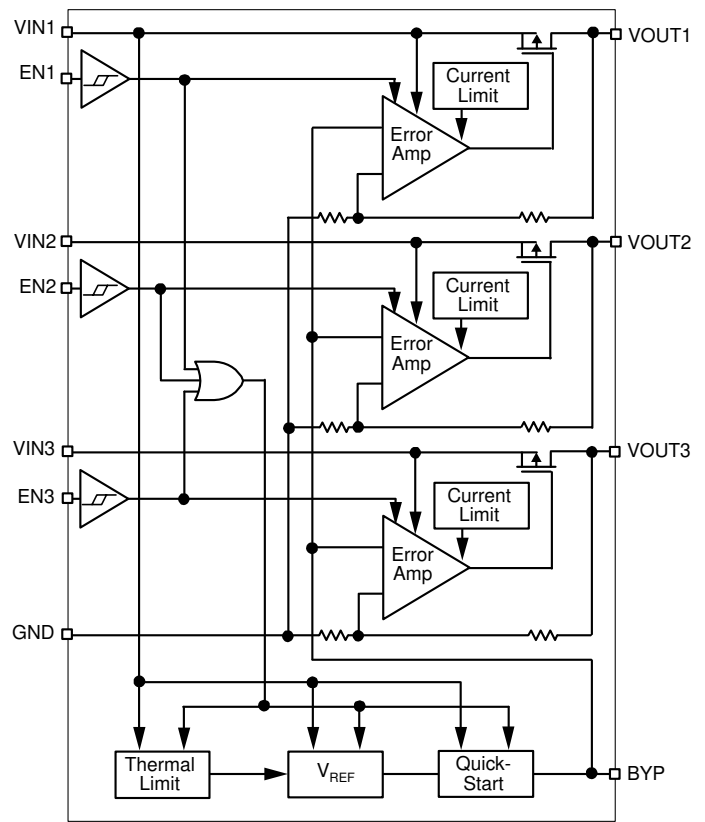

**MIC2215 Block Diagram
(Fixed)**

Functional Description

The MIC2215 is a triple, low noise CMOS LDO. Designed specifically for noise-critical applications in handheld or battery-powered devices, the MIC2215 comes equipped with a noise reduction feature to filter the output noise via an external capacitor. Other features of the MIC2215 include a separate logic compatible enable pin for each channel, current limit, thermal shutdown, and ultra-fast transient response, all within a small MLF[®] package.

The MIC2215 is specifically designed to work with low-ESR ceramic capacitors, reducing the amount of board space necessary for power applications, which is critical in hand-held wireless devices.

Application Information

Enable/Shutdown

The MIC2215 comes with three active-high enable pins that allow control of each individual regulator to be either disabled or enabled. Forcing the enable pin low disables the respective regulator and sends it into a “zero” off-mode-current state. In this state, current consumed by the individual regulator goes nearly to zero. This is true for both regulators 2 and 3. Regulator 1’s input supply pin is also used to power the internal reference. When any regulator; either 1, 2, or 3 is enabled, an additional 20 μ A for the reference will be drawn through V_{IN1} . All three must be disabled to enter the “zero” current-off-mode-state. Forcing the enable pin high enables each respective output voltage. This part is CMOS and none of the enable pins can be left floating; a floating enable pin may cause an indeterminate state on the output.

Input Capacitor

The MIC2215 is a high performance, high bandwidth device. Therefore, it requires a well-bypassed input supply for optimal performance. A small 0.1 μ F capacitor placed close to the input is recommended to aid in noise performance. Low-ESR ceramic capacitors provide optimal performance at a mini-mum of space. Additional high-frequency capacitors such as small valued NPO dielectric type capacitors help to filter out high frequency noise and are good practice in any RF-based circuit.

Output Capacitor

The MIC2215 requires an output capacitor for stability. The design requires 1 μ F or greater on the output to maintain stability. The design is optimized for use with low-ESR ceramic chip capacitors. X7R/X5R dielectric-type ceramic capacitors are recommended because of their temperature performance. X7R-type capacitors change capacitance by 15% over their operating temperature range and are the most stable type of ceramic capacitors. Z5U and Y5V dielectric capacitors change value by as much as 50% and 60%, respectively, over their operating temperature ranges. To use a ceramic chip capacitor with Y5V dielectric, the value must be much higher than an X7R ceramic capacitor to ensure the same minimum capacitance over the equivalent operating temperature range.

Bypass Pin

A capacitor can be placed from the noise bypass pin to ground to reduce output voltage noise. The capacitor bypasses the internal reference. There is one single internal reference shared by each output, therefore the bypassing affects each regulator. A 0.1 μ F capacitor is recommended for applications that require low-noise outputs. The bypass capacitor can be increased, further reducing noise and improving PSRR. Turn-on time increases slightly with respect to bypass capacitance.

Internal Reference

The internal band gap, or reference, is powered from the V_{IN1} input. Due to some of the input noise (PSRR) contributions being imposed on the band gap, it is important to make V_{IN1} as clean as possible with good bypassing close to the input.

Multiple Input Supplies

The MIC2215 can be used with multiple input supplies when desired. The only requirement, aside from maintaining the voltages within the operating ranges, is that V_{IN1} always remains the highest voltage potential.

No-Load Stability

The MIC2215 will remain stable and in regulation with no load, unlike many other voltage regulators. This is especially important in CMOS RAM keep-alive applications.

Thermal Considerations

The MIC2215 is designed to provide up to 250mA of current per channel in a very small package. Maximum power dissipation can be calculated based on the output current and the voltage drop across the part. To determine the maximum power dissipation of the package, use the junction-to-ambient thermal resistance of the device and the following basic equation:

$$P_{D(max)} = (T_{J(max)} - T_A) \div \theta_{JA}$$

$T_{J(max)}$ is the maximum junction temperature of the die, 125°C, and T_A is the ambient operating temperature. θ_{JA} is layout dependent; Table 2 shows examples of the junction-to-ambient thermal resistance for the MIC2215.

Package	θ_{JA} Recommended Minimum Footprint
16-Pin 4mm x 4mm MLF [®]	43°C/W

Table 2. MLF[®] Thermal Resistance

The actual power dissipation of the regulator circuit can be determined using the equation:

$$P_{DTOTAL} = P_{DLDO1} + P_{DLDO2} + P_{DLDO3}$$

$$P_{DLDO1} = (V_{IN1} - V_{OUT1}) \times I_{OUT1}$$

$$P_{DLDO2} = (V_{IN2} - V_{OUT2}) \times I_{OUT2}$$

$$P_{DLDO3} = (V_{IN3} - V_{OUT3}) \times I_{OUT3}$$

Substituting $P_{D(max)}$ for P_D and solving for the operating conditions that are critical to the application will give the maximum operating conditions for the regulator circuit. For example, when operating the MIC2215 at 60°C with a minimum footprint layout, the maximum load currents can be calculated as follows:

$$P_{D(max)} = (125^\circ\text{C} - 60^\circ\text{C})/43^\circ\text{C/W}$$

$$P_{D(max)} = 1.511\text{W}$$

The junction-to-ambient thermal resistance for the minimum footprint is 43°C/W, from Table 2. The maximum power dissipation must not be exceeded for proper operation. Using a lithium-ion battery as the supply voltage, 2.8V/250mA for channel 1, 3V/100mA for channel 2 and 2.8V/50mA for channel 3, maximum power can be calculated as follows:

$$P_{DLDO1} = (V_{IN1} - V_{OUT1}) \times I_{OUT1}$$

$$P_{DLDO1} = (4.2V - 2.8V) \times 250mA$$

$$P_{DLDO1} = 350mW$$

$$P_{DLDO2} = (V_{IN2} - V_{OUT2}) \times I_{OUT2}$$

$$P_{DLDO2} = (4.2V - 3.0V) \times 100mA$$

$$P_{DLDO2} = 120mW$$

$$P_{DLDO3} = (V_{IN3} - V_{OUT3}) \times I_{OUT3}$$

$$P_{DLDO3} = (4.2V - 2.8V) \times 50mA$$

$$P_{DLDO3} = 70mW$$

$$P_{DTOTAL} = P_{DLDO1} + P_{DLDO2} + P_{DLDO3}$$

$$P_{DTOTAL} = 350mW + 120mW + 70mW$$

$$P_{DTOTAL} = 540mW$$

The calculation shows that we are well below the maximum allowable power dissipation of 1.511W for a 60°C ambient temperature. After the maximum power dissipation has been calculated, it is always a good idea to calculate the maximum ambient temperature for a 125°C junction temperature. Calculating maximum ambient temperature as follows:

$$T_{A(max)} = T_{J(max)} - (P_D \times \theta_{JA})$$

$$T_{A(max)} = 125°C - (540mW \times 43°C/W)$$

$$T_{A(max)} = 101°C$$

For more information, please refer to the *Designing with Low-Dropout Voltage Regulators Handbook*.

Adjustable Regulator Application

Adjustable regulators use the ratio of two resistors to multiply the reference voltage to produce the desired output voltage. The MIC2215 can be adjusted from 1.25V to (5.5V-max $V_{DROPOUT}$) by using two external resistors (Figure 1). The resistors set the output voltage based on the following equation:

$$V_{OUT} = V_{REF} \left(1 + \frac{R1}{R2} \right)$$

$$V_{REF} = 1.25V$$

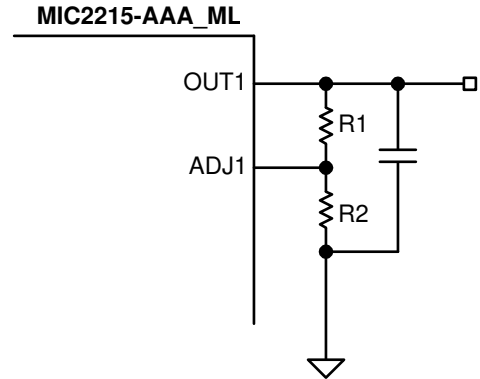
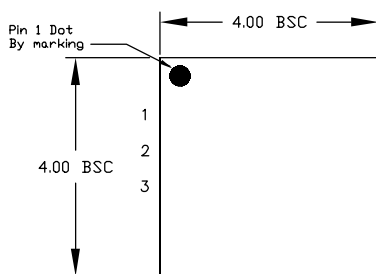
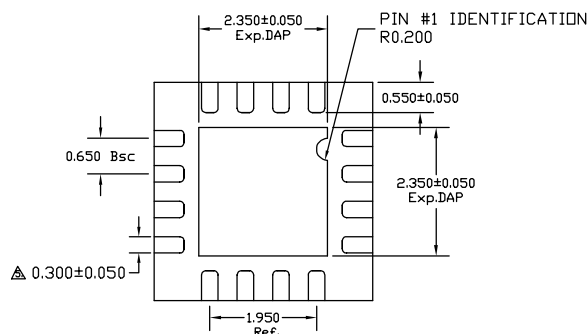

Figure 1. Adjustable Output

Package Information



TOP VIEW



BOTTOM VIEW



SIDE VIEW

NOTE:

1. ALL DIMENSIONS ARE IN MILLIMETERS.
 2. MAX. PACKAGE WARPAGE IS 0.05 mm.
 3. MAXIMUM ALLOWABLE BURRS IS 0.076 mm IN ALL DIRECTIONS.
 4. PIN #1 ID ON TOP WILL BE LASER/INK MARKED.
- △ DIMENSION APPLIES TO METALIZED TERMINAL AND IS MEASURED BETWEEN 0.20 AND 0.25 mm FROM TERMINAL TIP.
- △ APPLIED ONLY FOR TERMINALS.
- △ APPLIED FOR EXPOSED PAD AND TERMINALS.

16-Pin (4mm x 4mm) MLF[®] (ML)

MICREL, INC. 2180 FORTUNE DRIVE SAN JOSE, CA 95131 USA
 TEL +1 (408) 944-0800 FAX +1 (408) 474-1000 WEB <http://www.micrel.com>

The information furnished by Micrel in this data sheet is believed to be accurate and reliable. However, no responsibility is assumed by Micrel for its use. Micrel reserves the right to change circuitry and specifications at any time without notification to the customer.

Micrel Products are not designed or authorized for use as components in life support appliances, devices or systems where malfunction of a product can reasonably be expected to result in personal injury. Life support devices or systems are devices or systems that (a) are intended for surgical implant into the body or (b) support or sustain life, and whose failure to perform can be reasonably expected to result in a significant injury to the user. A Purchaser's use or sale of Micrel Products for use in life support appliances, devices or systems is a Purchaser's own risk and Purchaser agrees to fully indemnify Micrel for any damages resulting from such use or sale.

© 2004 Micrel, Incorporated.