

MATERIALS AND FINISHES

BODY ZINC ALLOY
PLATED NICKEL

CENTER CONTACT PHOSPHOR BRONZE
PLATED GOLD

INSULATOR POLYPROPYLENE(94 V-2)

HOUSING POLYESTER BUTLYENE TEREPHTHALATE
COLOR BLACK

MOUNTING POST BRASS
PLATED TIN

SOLDER TAIL BRASS WIRE
PLATED TIN

LOCKWASHER PHOSPHOR BRONZE
PLATED NICKEL

JAM NUT BRASS
PLATED NICKEL

BNC JACK
INTERFACE

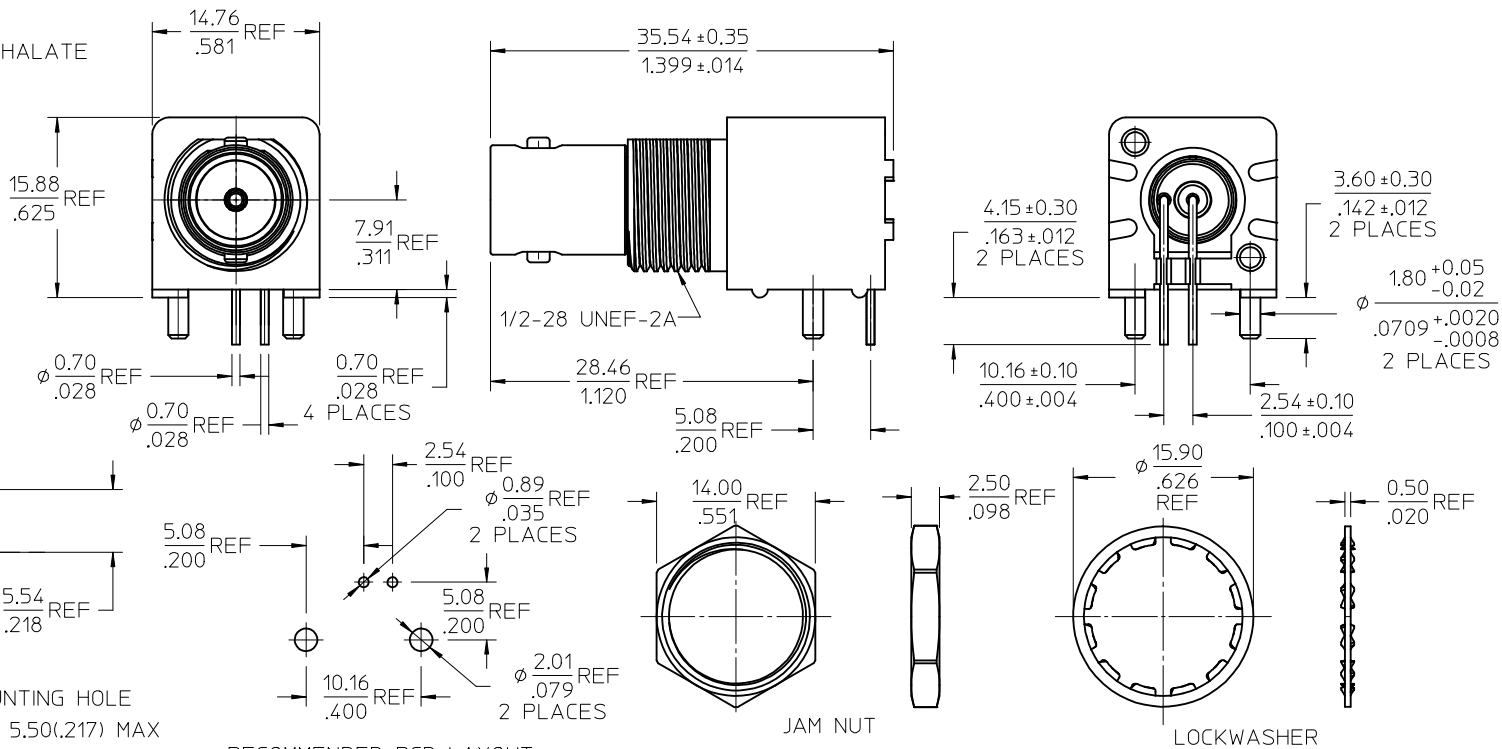
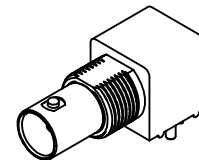

RECOMMENDED MOUNTING HOLE
PANEL THICKNESS: 5.50(.217) MAX
RECOMMENDED MOUNTING TORQUE:
0.56 N-m(5 INCH-LBS)

RECOMMENDED PCB LAYOUT

JAM NUT

LOCKWASHER

PS-73598-0051	PRODUCT SPECIFICATION
ES-73599-0000	INTERFACE
SPECIFICATION	DESCRIPTION

73171-3000	73100-0070, ONE PER BAG
73100-0070	PLASTIC TRAYS
PART NO.	PACKAGING

CHG DIM: 7.91 WAS 7.60
PER RF13-E120
EC NO: URF2013-0653
DRWING: CME102 2013/05/22
CHKD:
APPR: MHUANG 2013/05/30
DESCRIPTION

QUALITY SYMBOLS	GENERAL TOLERANCES (UNLESS SPECIFIED)
▽=0	mm INCH
▽=0	4 PLACES ± --- ± ---
	3 PLACES ± --- ± ---
	2 PLACES ± --- ± ---
	1 PLACE ± --- ± ---
	ANGULAR ± 2 °
	DRAFT WHERE APPLICABLE MUST REMAIN WITHIN DIMENSIONS

DIMENSION STYLE MM/IN	
DRAWN BY	DATE
CHECKED BY	DATE
APPROVED BY	DATE
MATERIAL NO.	DOCUMENT NO.
SIZE	SEE TABLE

SCALE	DESIGN UNITS METRIC	THIRD ANGLE PROJECTION
BNC JACK, R/A PCB RECEPTACLE, 75 OHMS BNC-J/RA/PCB		
MOLEX INCORPORATED		
SD-73100-0070		SHEET NO. 1 OF 1
THIS DRAWING CONTAINS INFORMATION THAT IS PROPRIETARY TO MOLEX INCORPORATED AND SHOULD NOT BE USED WITHOUT WRITTEN PERMISSION		