

Metric table



Dimensions in: millimeters - inches

l_1	b	d	h_1	h_2	l_2	l_3	l_4
57 2.24	6.3 0.25	6 0.24	12 0.47	6.5 0.26	50 1.97	28.5 1.12	28.5 1.12
68 2.68	6.3 0.25	6 0.24	12 0.47	6.5 0.26	50 1.97	28.5 1.12	40 1.57
80 3.15	6.3 0.25	6 0.24	12 0.47	6.5 0.26	50 1.97	40 1.57	40 1.57

Specification

- Body
Zinc die-cast, powder coated
Black, textured finish
- Pin
Stainless steel AISI 303
- [Load Rating Information](#) → page QVX
- [Stainless Steel Characteristics](#) → page QVX
- [RoHS compliant](#)

Information

GN 161 hinges were designed for commercially available aluminum profiles.

With the three offered sizes of hinges, 66 different slot widths (n dimension) can be accommodated. To achieve this, the positioning components are set in specially marked recesses in the hinge wings.

The rectangular (8x10 mm) positioning elements, two pieces per hinge wing, prevent misalignment. They also support the weight of the door. To screw the hinges onto the profiles, use special T-nuts with guide step GN 505.

Can be used with GN 965 / GN 968 T-nut assemblies.

Swiveling range

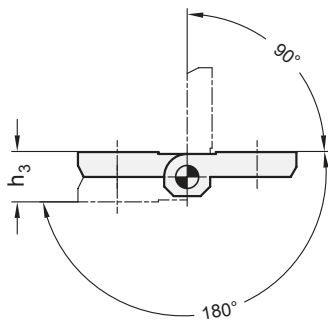

Assembly instruction and application example

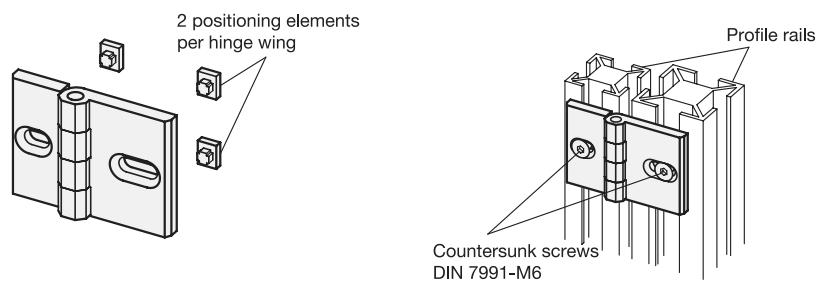

How to order

GN 161-68

1 Length l_1

GN 161-57 n Slot distance	m ₁	m ₂	GN 161-68 n Slot distance	m ₁	m ₂	GN 161-80 n Slot distance	m ₁	m ₂
33 1.30	16.5 0.65	16.5 0.65	37.5 1.48	16.5 0.65	21 0.83	42 1.65	21 0.83	21 0.83
34 1.34	16.5 0.65	17.5 0.69	38 1.50	16.5 0.65	21.5 0.85	42.5 1.67	21 0.83	21.5 0.85
35 1.38	16.5 0.65	18.5 0.73	39 1.54	16.5 0.65	22.5 0.89	43.5 1.71	21 0.83	22.5 0.89
35.5 1.40	16.5 0.65	19 0.75	40 1.57	16.5 0.65	23.5 0.93	44.5 1.75	21 0.83	23.5 0.93
36.5 1.44	16.5 0.65	20 0.79	42.5 1.67	16.5 0.65	26 1.02	47 1.85	21 0.83	26 1.02
35 1.38	17.5 0.69	17.5 0.69	44 1.73	16.5 0.65	27.5 1.08	48.5 1.91	21 0.83	27.5 1.08
36 1.42	17.5 0.69	18.5 0.73	47.5 1.87	16.5 0.65	31 1.22	52 2.05	21 0.83	31 1.22
36.5 1.44	17.5 0.69	19 0.75	38.5 1.52	17.5 0.69	21 0.83	43 1.69	21.5 0.85	21.5 0.85
37.5 1.48	17.5 0.69	20 0.79	39 1.54	17.5 0.69	21.5 0.85	44 1.73	21.5 0.85	22.5 0.89
37 1.46	18.5 0.73	20 0.79	40 1.57	17.5 0.69	22.5 0.89	45 1.77	21.5 0.85	23.5 0.93
37.5 1.48	20 0.79	19 0.75	41 1.61	17.5 0.69	23.5 0.93	47.5 1.87	21.5 0.85	26 1.02
38.5 1.52	18.5 0.73	20 0.79	43.5 1.71	17.5 0.69	26 1.02	49 1.93	21.5 0.85	27.5 1.08
38 1.50	19 0.75	19 0.75	45 1.77	17.5 0.69	27.5 1.08	52.5 2.07	21.5 0.85	31 1.22
39 1.54	19 0.75	20 0.79	48.5 1.91	17.5 0.69	31 1.22	45 1.77	22.5 0.89	22.5 0.89
40 1.57	20 0.79	20 0.79	39.5 1.56	18.5 0.73	21 0.83	46 1.81	22.5 0.89	23.5 0.93
-	-	-	40 1.57	18.5 0.73	21.5 0.85	48.5 1.91	22.5 0.89	26 1.02
-	-	-	41 1.61	18.5 0.73	22.5 0.89	50 1.97	22.5 0.89	27.5 1.08
-	-	-	42 1.65	18.5 0.73	23.5 0.93	53.5 2.11	22.5 0.89	31 1.22
-	-	-	44.5 1.75	18.5 0.73	26 1.02	47 1.85	23.5 0.93	23.5 0.93
-	-	-	46 1.81	18.5 0.73	27.5 1.08	49.5 1.95	23.5 0.93	26 1.02
-	-	-	49.5 1.95	18.5 0.73	31 1.22	51 2.01	23.5 0.93	27.5 1.08
-	-	-	40 1.57	19 0.75	21 0.83	54.5 2.15	23.5 0.93	31 1.22
-	-	-	40.5 1.59	19 0.75	21.5 0.85	52 2.05	26 1.02	26 1.02
-	-	-	41.5 1.63	19 0.75	22.5 0.89	53.5 2.11	26 1.02	27.5 1.08
-	-	-	42.5 1.67	19 0.75	23.5 0.93	57 2.24	26 1.02	31 1.22
-	-	-	45 1.77	19 0.75	26 1.02	55 2.17	27.5 1.08	27.5 1.08
-	-	-	46.5 1.83	19 0.75	27.5 1.08	58.5 2.30	27.5 1.08	31 1.22
-	-	-	50 1.97	19 0.75	31 1.22	62 2.44	31 1.22	31 1.22
-	-	-	41 1.61	20 0.79	21 0.83	-	-	-
-	-	-	41.5 1.63	20 0.79	21.5 0.85	-	-	-
-	-	-	43.5 1.71	20 0.79	23.5 0.93	-	-	-
-	-	-	46 1.81	20 0.79	26 1.02	-	-	-
-	-	-	47.5 1.87	20 0.79	27.5 1.08	-	-	-
-	-	-	51 2.01	20 0.79	31 1.22	-	-	-

3.1
3.2
3.3
3.4
3.5
3.6
3.7
3.8
3.9
3.10