

P	LTR	DESCRIPTION	DATE	DWN	APVD
C		REV PER ECO 19-019314	2-27-20	CT	PD

1. MATERIAL:
BODY: ALUMINUM PER ASTM B317
INSERT: BRASS PER ASTM B36
2. FINISH:
BODY: .000600 MIN MATTE TIN PER ASTM B545
OVER .000060 MIN NICKEL PER ASTM B733.
INSERT: .000150 MIN MATTE NICKEL PER QQ-N-290
3. PTFE DRY LUBRICANT 360 DEGREE ON OUTER DIAMETER OF CRIMP BARREL IN ZONE SHOWN.
4. WIRE INSULATION RANGE: .520-.633.
5. SEE TE CONNECTIVITY APPLICATION SPEC. 114-32098 FOR APPLICATION REQUIREMENTS.
6. SEE TE CONNECTIVITY INSTRUCTION SHEET 408-32087 FOR TOOLING AND CRIMP INSTRUCTIONS, FIGURE 3 FOR WIRE STRIPPING DETAIL.

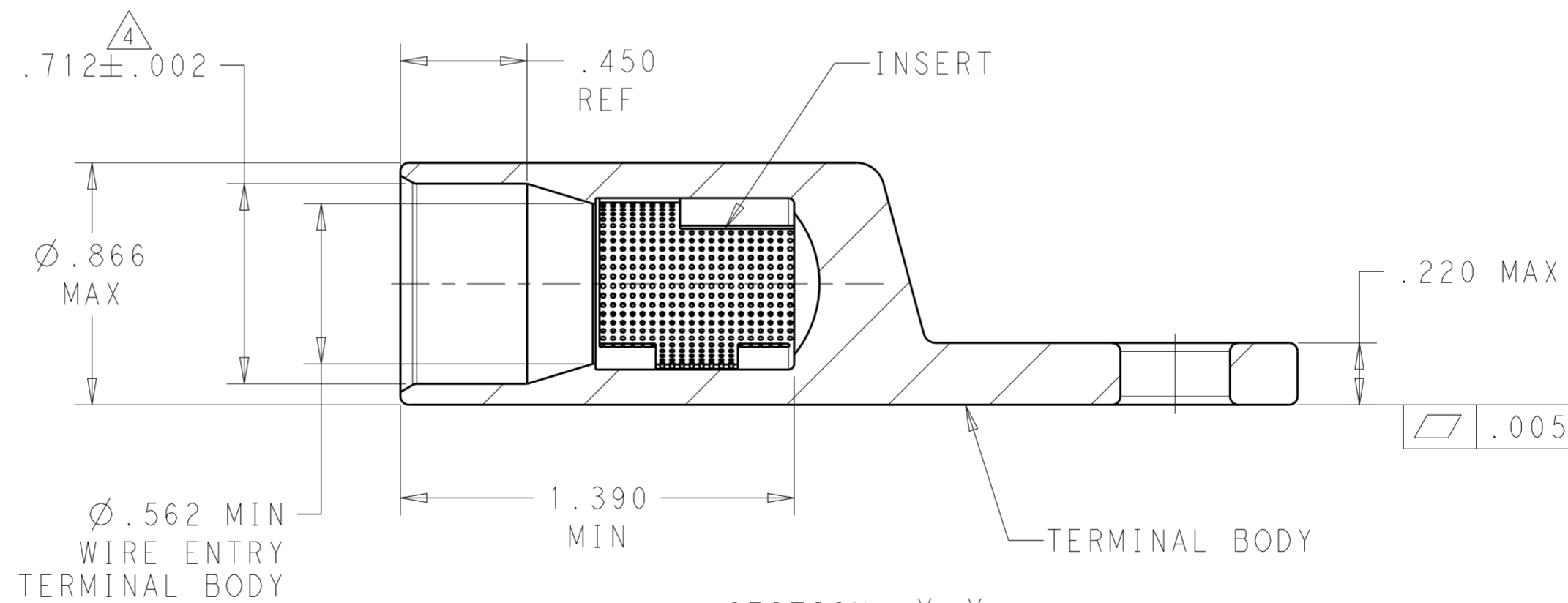
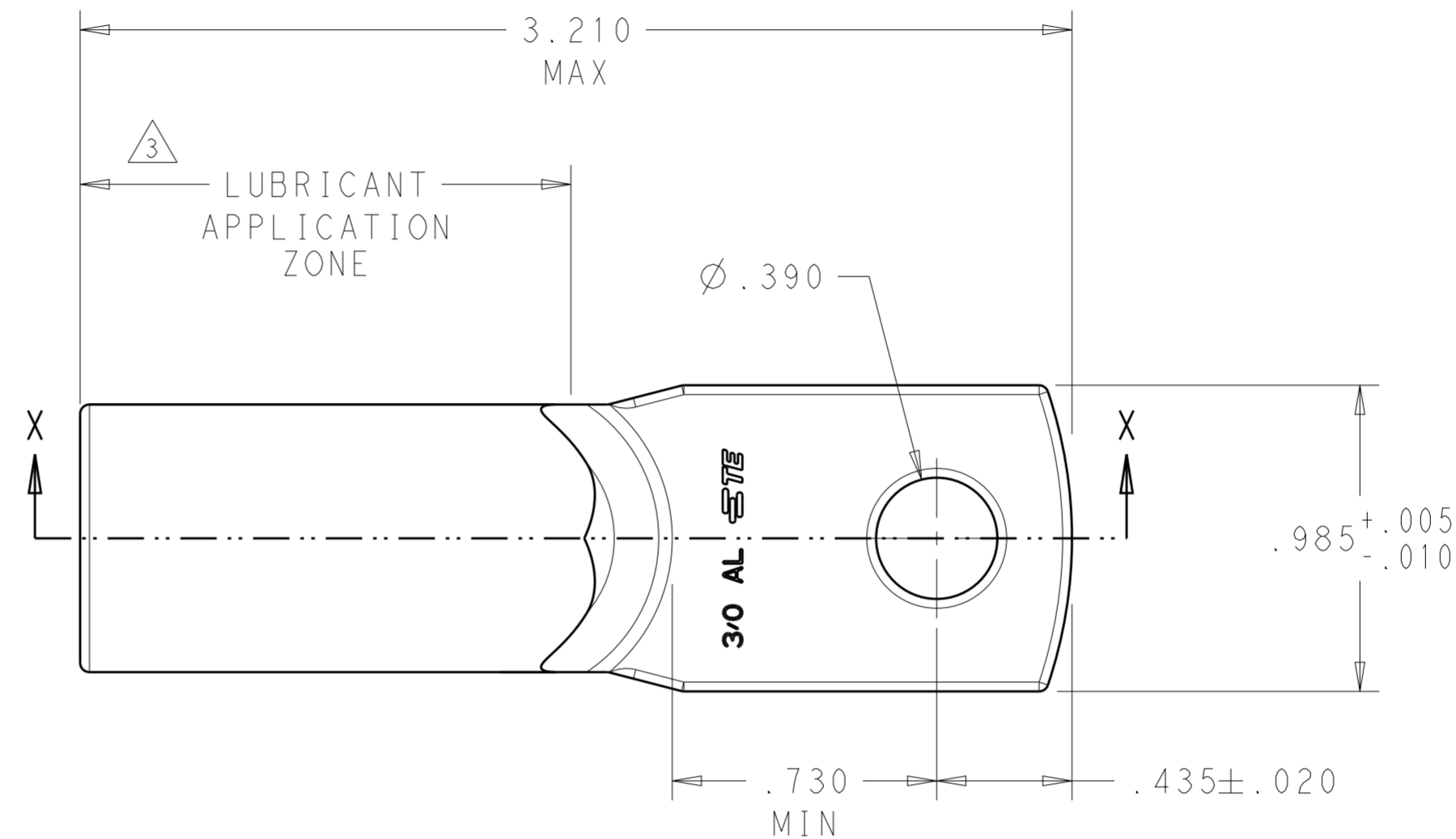
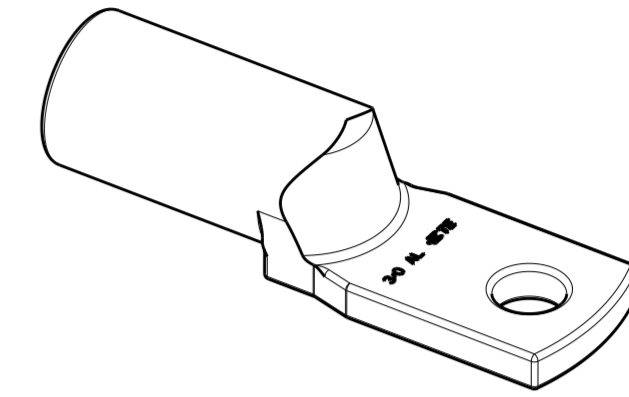

SECTION X-X

2102574-1
PART NUMBER

THIS DRAWING IS A CONTROLLED DOCUMENT.		DWN D. FABIAN 15NOV2011	TE Connectivity	
DIMENSIONS: IN		CHK DEBOCK, KIM 28NOV2012		
TOLERANCES UNLESS OTHERWISE SPECIFIED:		APVD DEBOCK, KIM 28NOV2012	NAME ASSEMBLY, ALUMINUM TERMINAL, STRAIGHT, SINGLE HOLE, 3/0	
0 PLC ±-		PRODUCT SPEC	SIZE	
1 PLC ±.1		APPLICATION SPEC	CAGE CODE	
2 PLC ±.01		WEIGHT	DRAWING NO	
3 PLC ±.005		CUSTOMER DRAWING	RESTRICTED TO	
4 PLC ±.0005		SCALE 2:1	SHEET 1 OF 1	
ANGLES ±1°		SCALE 2:1	REV C	
FINISH		A200779 C-2102574		
MATERIAL SEE CALL-OUT		CUSTOMER DRAWING		
SEE CALL-OUT		SCALE 2:1 SHEET 1 OF 1 REV C		