

TRIPLE 3-INPUT "AND" GATE

MTTL III MC3100/3000 series

MC3106F · MC3006F
MC3106L · MC3006L,P
 (54H11J) (74H11J,N)

1/3 OF CIRCUIT SHOWN

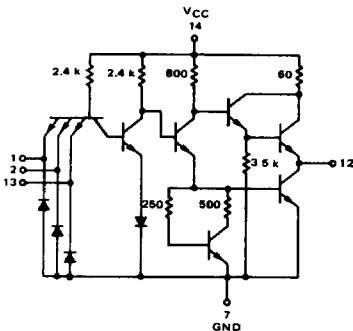

This device consists of three 3-input AND gates. This non-inverting function is useful for optimizing logic design, or for direct implementation of standard logic equations.

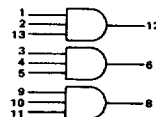

Positive Logic: $12 = 1 \cdot 2 \cdot 13$
 Negative Logic: $12 = 1 + 2 + 13$

Input Loading Factor = 1
 Output Loading Factor = 10

Total Power Dissipation = 84 mW typ/pkg
 Propagation Delay Time = 9.0 ns typ

SWITCHING TIME TEST CIRCUIT

VOLTAGE WAVEFORMS AND DEFINITIONS

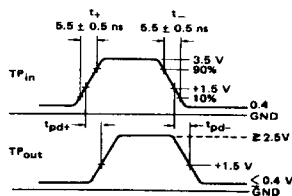
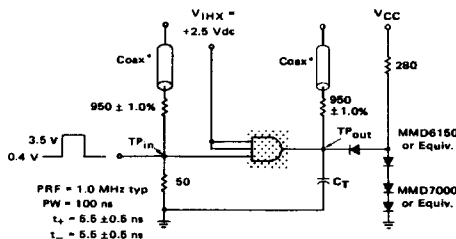

*The coax delays from input to scope and output to scope must be matched. The scope must be terminated in 50-ohm impedance. The 950-ohm resistor and the scope termination impedance constitute a 20:1 attenuator probe. Coax shall be CT-070-50 or equivalent.

$C_T = 25 \text{ pF}$ = total parasitic capacitance, which includes probe, wiring, and load capacitances.

See General Information section for packaging.

27

MC3106F, MC3006F/MC3106L, MC3006L,P (continued)

ELECTRICAL CHARACTERISTICS

Test procedures are shown for only one gate. The other gates are tested in the same manner. Further, test procedures are shown for only one input of the gate under test. To complete testing, sequence through remaining inputs.

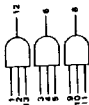

Characteristic	Symbol	Pin Under Test	MC3106 Test Limits						MC3006 Test Limits						TEST CURRENT / VOLTAGE VALUES																							
			-55°C		-25°C		0°C		+25°C		+75°C		-55°C		-25°C		0°C		+25°C		+75°C		mA				Volts											
			Min	Max	Min	Max	Min	Max	Min	Max	Min	Max	Min	Max	Min	Max	Min	Max	Min	Max	Min	Max	I _{OL}	I _{OH}	I _b	I _{in}	V _{OL}	V _{OH}	V _F	V _{IN}	V _{IS}	V _{OS}	V _{CC1}	V _{CC2}	V _{CC3}	V _{CC4}		
Input Forward Current	I _F	1	-2.0	-	-2.0	-	-2.0	-	-2.0	-	-2.0	-	-2.0	-	-2.0	-	-2.0	-	-2.0	-	-2.0	-	-	-	-	-	-	-	-	-	-	-	-	-	-	-	-	
Leakage Current	I _L	1	50	-	50	-	50	-	50	-	50	-	50	-	50	-	50	-	50	-	50	-	-	-	-	-	-	-	-	-	-	-	-	-	-	-	-	
Breakdown Voltage	BV _{IN}	1	-	-	-	-	-	-	-	-	-	-	-	-	-	-	-	-	-	-	-	-	-	-	-	-	-	-	-	-	-	-	-	-	-	-	-	
Clamp Voltage	V _D	1	-	-	-1.5	-	-	-	-	-	-	-	-1.5	-	-	-	-	-	-	-	-	-	-	-	-	-	-	-	-	-	-	-	-	-	-	-	-	
Output	V _{OL}	12	-	0.4	-	0.4	-	0.4	-	0.4	-	0.4	-	0.4	-	0.4	-	0.4	-	0.4	-	-	-	-	-	-	-	-	-	-	-	-	-	-	-	-	-	
	V _{OH}	12	2.4	-	2.4	-	2.4	-	2.4	-	2.5	-	2.5	-	2.5	-	2.5	-	2.5	-	2.5	-	-	-	-	-	-	-	-	-	-	-	-	-	-	-	-	
Short-Circuit Current	I _{SC}	12	-40	-100	-40	-100	-40	-100	-40	-100	-40	-100	-40	-100	-40	-100	-40	-100	-40	-100	-40	-	-	-	-	-	-	-	-	-	-	-	-	-	-	-	-	-
Power Requirements (Tand Device)	I _{max}	14	-	-	-	-	-	-	-	-	-	-	-	-	-	-	-	-	-	-	-	-	-	-	-	-	-	-	-	-	-	-	-	-	-	-	-	
	Maximum Power Supply Current	I _{ppH}	14	-	18	-	18	-	18	-	18	-	18	-	18	-	18	-	18	-	18	-	-	-	-	-	-	-	-	-	-	-	-	-	-	-	-	-
	Power Supply Drain	I _{ppL}	14	-	36	-	36	-	36	-	36	-	36	-	36	-	36	-	36	-	36	-	-	-	-	-	-	-	-	-	-	-	-	-	-	-	-	-
Switching Parameters	Turn-On Delay	t _{pol}	1,12	-	-	-	15	-	15	-	15	-	15	-	15	-	15	-	15	-	15	-	-	-	-	-	-	-	-	-	-	-	-	-	-	-	-	
	Turn-Off Delay	t _{pot}	1,12	-	-	-	12	-	12	-	12	-	12	-	12	-	12	-	12	-	12	-	-	-	-	-	-	-	-	-	-	-	-	-	-	-	-	

* Since gate is a non-inverting gate, power drain is minimized by tying the inputs to gates not under test to V_{RR}.

28

AC ELECTRICAL CHARACTERISTICS

The timing waveforms in the AC Electrical Characteristics are tested with a V_{IL} maximum of 0.5 V and a V_{IH} minimum of 2.4 V for all pins, except EXTAL, RESET, MODA, MODB, and MODC. These pins are tested using the input levels set forth in the DC Electrical Characteristics. AC timing specifications that are referenced to a device input signal are measured in production with respect to the 50% point of the respective input signal's transition. DSP56002 output levels are measured with the production test machine V_{OL} and V_{OH} reference levels set at 0.8 V and 2.0 V, respectively.

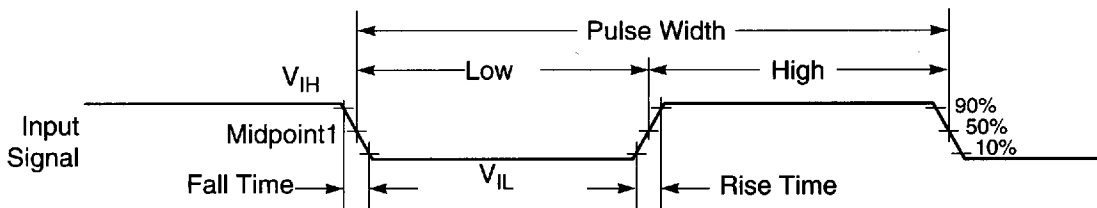

Note: The midpoint is $V_{IL} + (V_{IH} - V_{IL})/2$.

AA0179

Figure 2-1 Signal Measurement Reference