

TOLERANCE UNLESS SPECIFIED
 WITHIN 1.5: ±0.1mm
 OVER 1.5: ±0.2mm
 ANGLES: ±2°

THIS IS A C.A.D. GENERATED DRAWING
 DO NOT MAKE MANUAL REVISIONS TO MASTER.

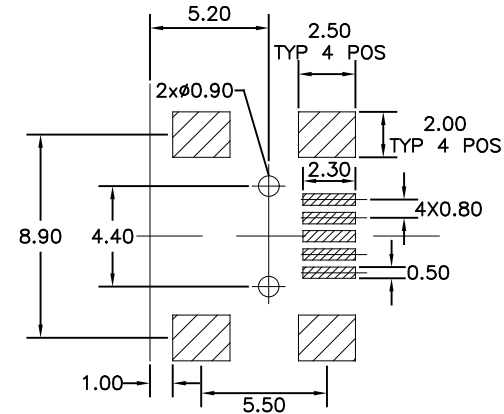
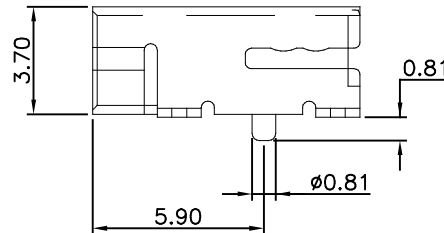
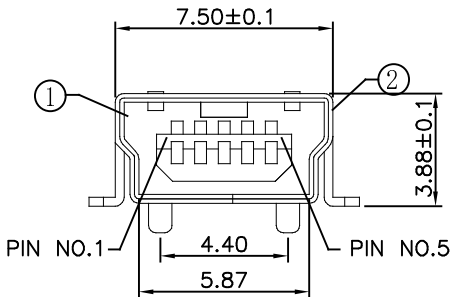
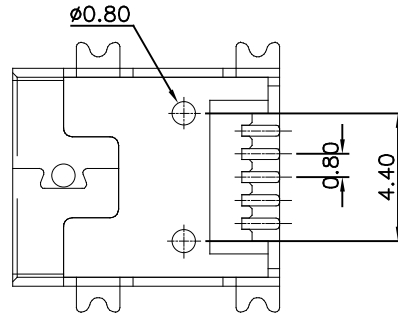
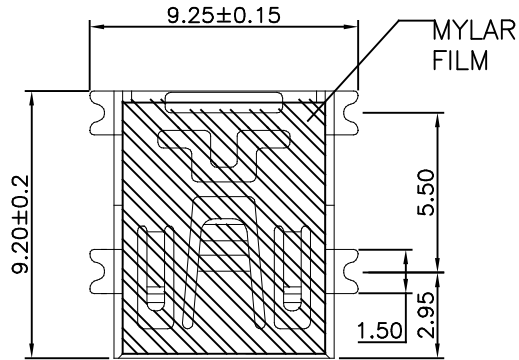

RECOMMENDED PCB LAYOUT

Materials:

- ① Housing: Thermoplastic UL94V-0 Black color.
- ② Shell: Brass, Nickel plated.
- ③ Contact: Phosphor Bronze Gold plated on contact are Tin on tail over Nickel-Under plating.

Specifications:

1. Current rating: 1 A Max.
2. Dielectric withstanding:voltage: 100 V(ac) for 1 min.
3. Contact resistance: 50 mW Max.
4. Insulation resistance: 100 MW Min.
5. Total mating force: 3.57 Kgf Max.
6. Total unmating force: 1.0 Kgf Min.0.81~2.05 Kgf Min.
- After 3000 insertion/extraction cycles.
7. Temperature range: -30°C~+80°C

Soldering temperature: 260°C±5°C for 5±0.5 sec.
 Resistance to soldering heat: 260°C±5°C for 5±0.5 sec.
 Storage temperature range: -20°C to +60°C
 Thermal resistance: 96 hours in 60°C±3°C

Plating Options
 Gold Flash
 30 Microinches

Part Number
 690-005-299-043
 690-005-699-043

ISSUE NUMBER

DRAWING UPDATED NEW TOOLING N.SONDH JAN.27/15	④
PIN NO'S ADDED F.BRIONES JAN.28/15	⑤
SOLDERING TEMP. ETC. ADDING F.BRIONES JUL.29/15	⑥
ADD TAPE & REEL INFORMATION R.STA.MONICA AUG.18/2015	⑦
UPDATE DWG ADD MYLAR FILM R.STA.MONICA NOV.17/2016	⑧
UPDATE DWG J.TAN MAY.03/2017	⑨
CHANGE ORIENTATION OF PARTS ON REEL P.M. NOV. 15/2019	⑩
ADD "TRANSPARENT COLOR" NOTE ON TAPE & REEL SPECS DWG P.M. JUNE 24/2020	⑪



THIS SERIES FULLY CONFORMS TO THE
 EUROPEAN UNION DIRECTIVES
 2011/65/EU FOR RoHS COMPLIANCY.

5 PIN MINI USB-B RIGHT ANGLE SURFACE MOUNT

EDAC EDAC INC
 TORONTO, ONTARIO
 CANADA
 YOUR CONNECTION TO QUALITY & SERVICE

THESE DRAWINGS AND SPECIFICATIONS
 ARE THE PROPERTY OF EDAC INC.,AND
 SHALL NOT BE REPRODUCED,OR COPIED
 OR USED AS THE BASIS FOR THE
 MANUFACTURE OR SALE OF APPARATUS
 WITHOUT WRITTEN PERMISSION.

ACAD REFERENCE NO.	690-005-299-043	
DRAWN:	N.SONDH	DATE: JAN.27/15
CHECKED:	R.E.	DATE: NOV.15/19
SCALE: (IN C.A.D. 1:1)	SHEET 1 OF 2	
DRAWING NUMBER	690-005-299-043	ISSUE 11

THIS IS A C.A.D. GENERATED DRAWING
DO NOT MAKE MANUAL REVISIONS TO MASTER.

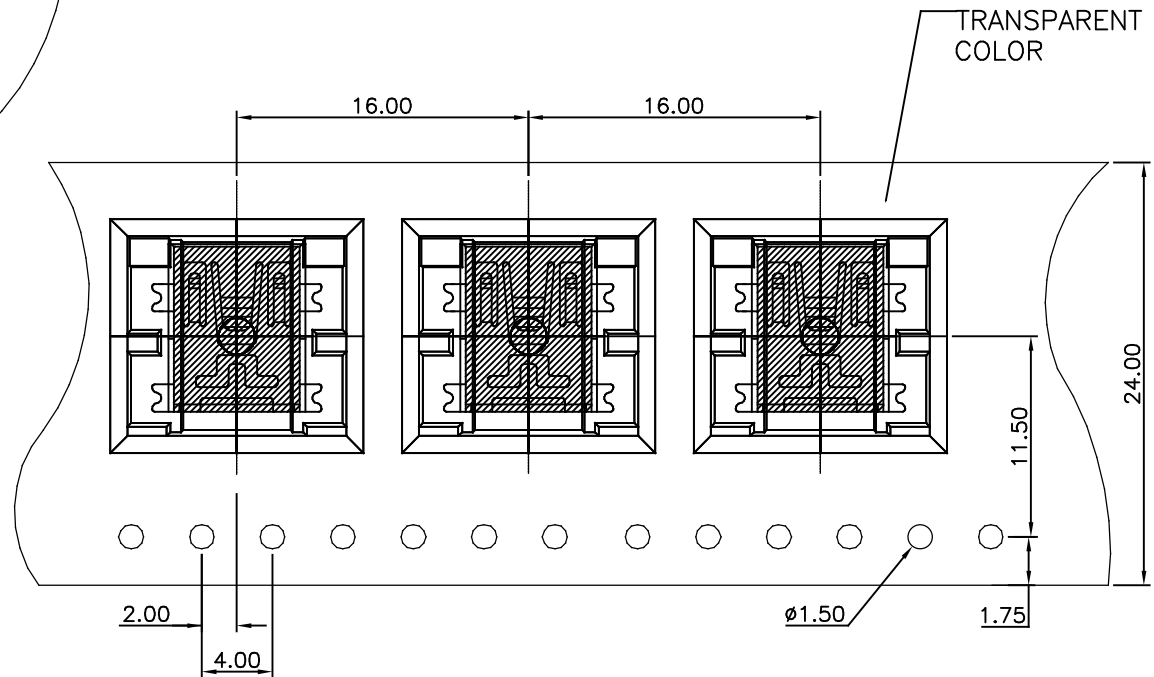
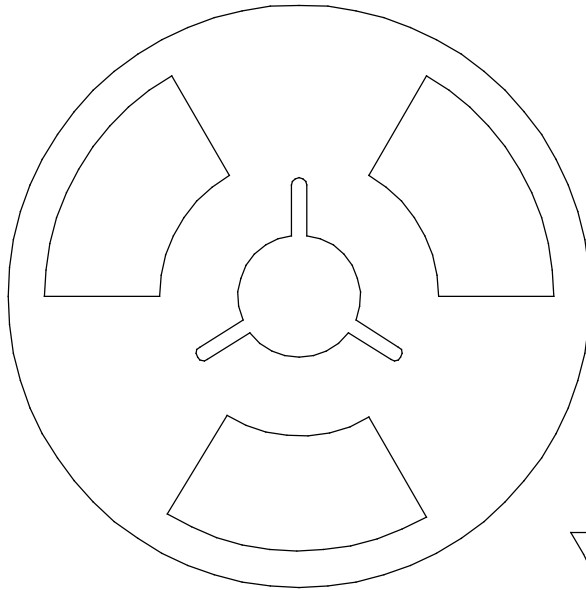
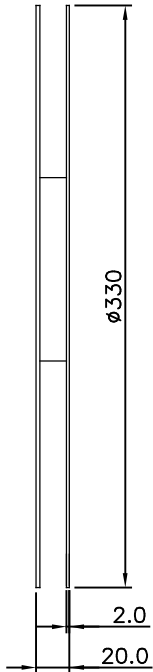

QUANTITY: 1,000 PCS PER REEL



THIS SERIES FULLY CONFORMS TO THE EUROPEAN UNION DIRECTIVES 2011/65/EU FOR RoHS COMPLIANCY.

5 PIN MINI USB-B RIGHT ANGLE SURFACE MOUNT
TAPE AND REEL SPECS

EDAC EDAC INC
TORONTO, ONTARIO
CANADA
YOUR CONNECTION TO QUALITY & SERVICE

THESE DRAWINGS AND SPECIFICATIONS ARE THE PROPERTY OF EDAC INC., AND SHALL NOT BE REPRODUCED, OR COPIED OR USED AS THE BASIS FOR THE MANUFACTURE OR SALE OF APPARATUS WITHOUT WRITTEN PERMISSION.

ACAD REFERENCE NO.	690-005-299-043	
DRAWN: R.STA.MONICA	DATE: AUG.18/15	
CHECKED: R.E.	DATE: NOV.15/19	
SCALE: (IN C.A.D. 1:1)	SHEET 2 OF 2	
DRAWING NUMBER	690-005-299-043	ISSUE
		11