



# **Magnetic Buzzer With SMD**

**7.5×7.5×2.5mm**

**CC07MP025M16-2700**

## **Revision**

<b>Date</b>	<b>Version</b>	<b>Status</b>	<b>Changes</b>	<b>Approver</b>
2020/6/9	V0.1	Draft	First release	AX

## A. SCOPE

Specifications

This specification applies magnetic buzzer,

## B. SPECIFICATION

No.	Item	Unit	Specification	Condition
1	Oscillation Frequency	Hz	2700	Vo-p=1/2duty , square wave
2	Operating Voltage	Vo-p	2.5~4.5	
3	Rated Voltage	Vo-p	3.6	
4	Current Consumption	mA	MAX. 100	at Rated Voltage
5	Sound Pressure Level	dB	MIN. 80	at 10cm at Rated Voltage
6	Coil Resistance	$\Omega$	16 $\pm$ 3	
7	Operating Temperature	$^{\circ}\text{C}$	-30 ~ +70	
8	Storage Temperature	$^{\circ}\text{C}$	-40 ~ +85	
9	Dimension	mm	7.5 x 7.5 x H2.5	See appearance drawing
10	Weight (MAX)	gram	0.8	
11	Housing Material		LCP( Black )	
12	Leading Pin		Tin Plated Brass(Sn)	See appearance drawing
13	Environmental Protection Regulation		RoHS	

## C. APPEARANCE DRAWING

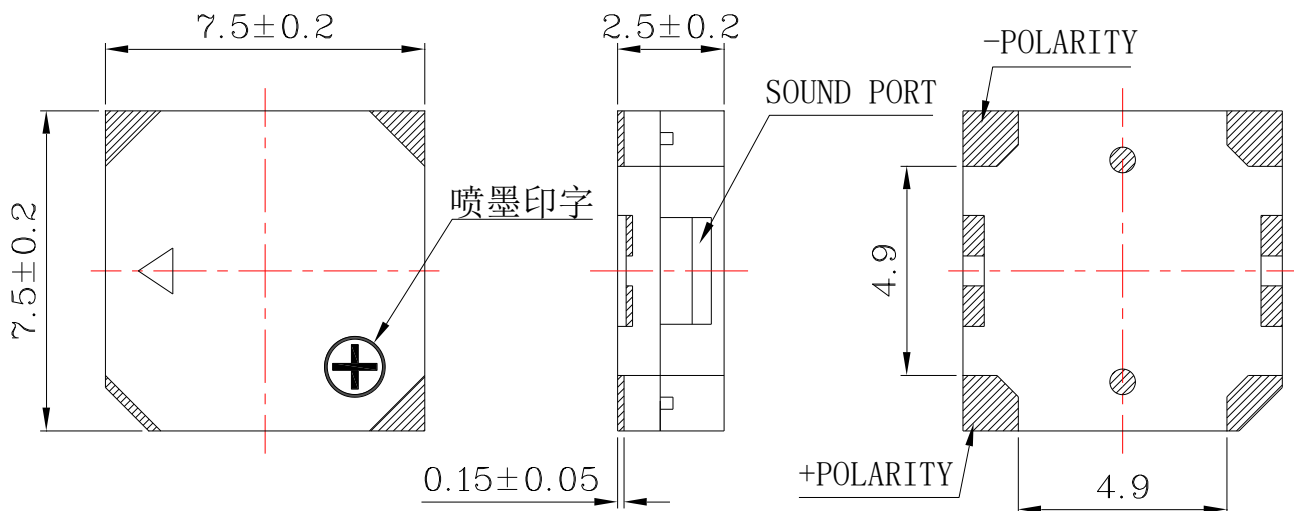

**Tol :  $\pm 0.5$**

**Unit: mm**

## D. TESTING METHOD

Specifications

### Standard Measurement conditions

Temperature:  $25 \pm 2^\circ\text{C}$  Humidity: 45-65%

### Acoustic Characteristics:

The oscillation frequency, current consumption and sound pressure are measured by the measuring instruments shown below

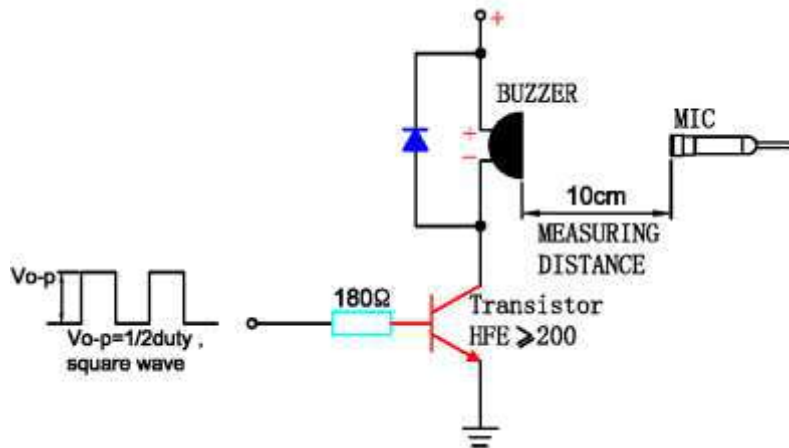

In the measuring test, buzzer is placed as follows:

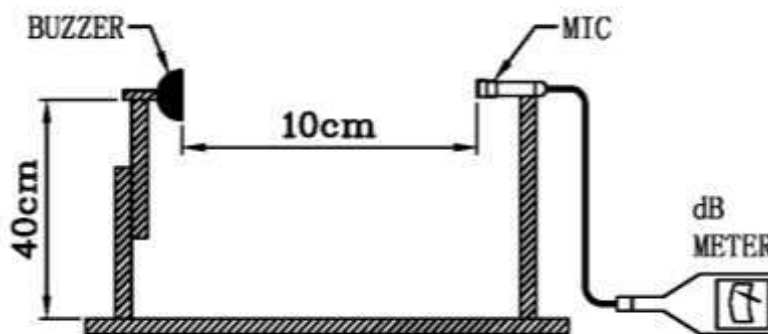

## E. Typical Frequency Response Curve

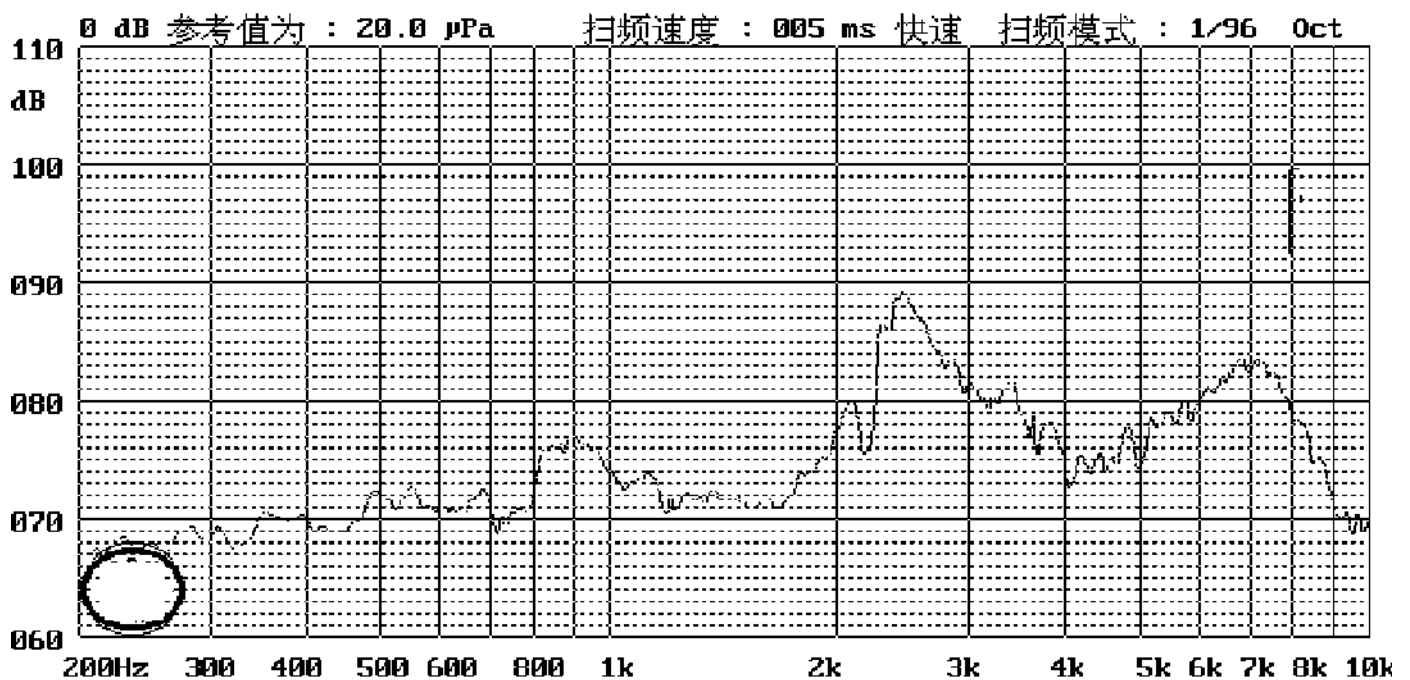

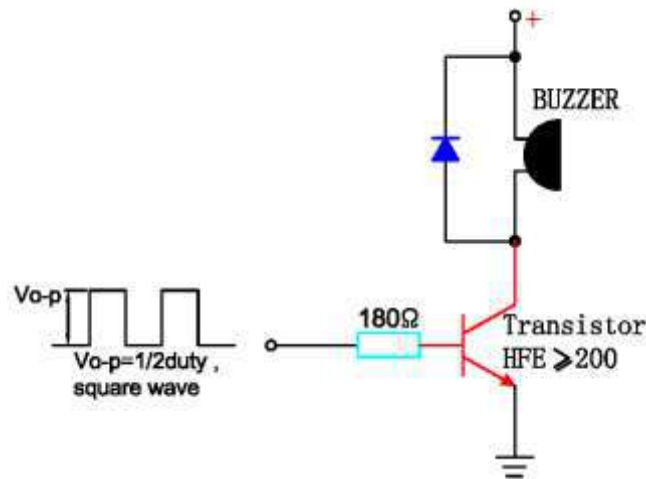

The base current  $I_b$  should be high enough so that it saturates the collector current of the transistor with the CB load.

G. Soldering Condition

- (1) Recommendable reflow soldering condition is as follows
- (Reflow soldering is twice)

Note: It is requested that reflow soldering should be executed after heat of product goes down to normal.

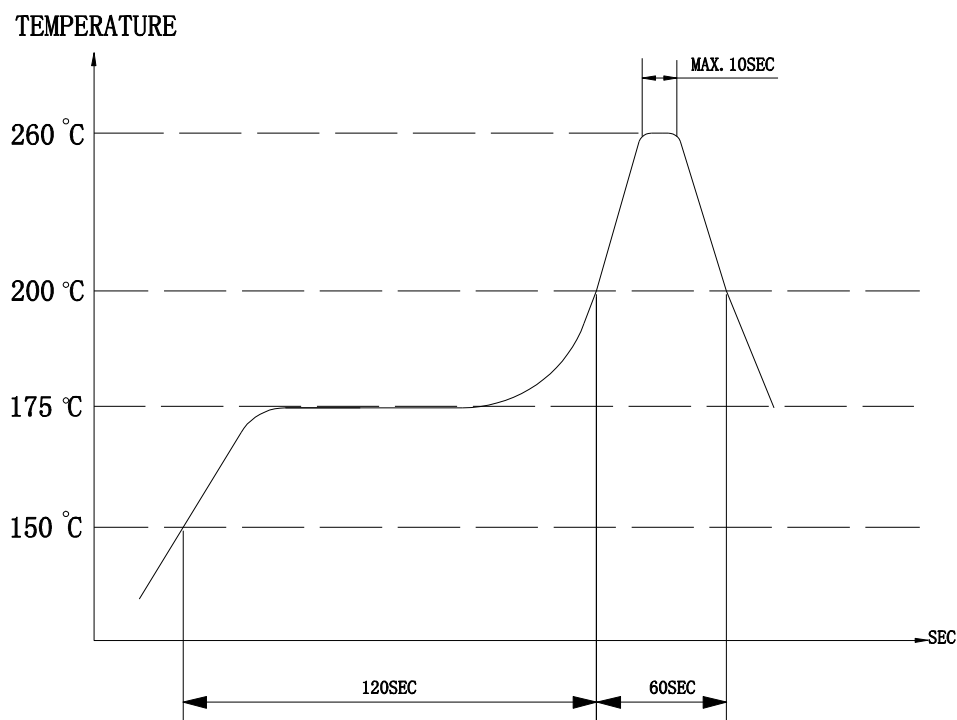

Heat resistant line

(Used when heat resistant reliability test is performed)

- (2) Manual soldering

Manual soldering temperature 350 °C within 5 sec.

**H. RELIABILITY TEST**

NO.	ITEM	TEST CONDITION AND REQUIREMENT
1	High Temperature Test (Storage)	After being placed in a chamber with 85±2°C for 96 hours and then being placed in normal condition for 2 hours. Allowable variation of SPL after test: ±10dB.
2	Low Temperature Test (Storage)	After being Placed in a chamber with -40±2°C for 96 hours and then being placed in normal condition for 2 hours. Allowable variation of SPL after test: ±10dB.
3	Humidity Test	After being Placed in a chamber with 90-95% R.H. at 40±2°C for 96 hours and then being placed in normal condition for 2 hours. Allowable variation of SPL after test: ±10dB.
4	Temperature Cycle Test	<p>The part shall be subjected to 5 cycles. One cycle shall be consist of :</p> <p>Allowable variation of SPL after test: ±10dB.</p>
5	Drop Test	Drop on a hard wood board of 4cm thick, any directions ,6 times, at the height of 75cm . Allowable variation of SPL after test: ±10dB.
6	Vibration Test	After being applied vibration of amplitude of 1.5mm with 10 to 55 Hz band of vibration frequency to each of 3 perpendicular directions for 2 hours . Allowable variation of SPL after test: ±10dB.
7	Solderability Test	Lead terminals are immersed in rosin for 5 seconds and then immersed in solder bath of +300±5°C for 3±1 seconds . 90% min. lead terminals shall be wet with solder (Except the edge of terminals).
8	Terminal Strength Pulling Test	The force of 9.8N(1.0kg) is applied to each terminal in axial direction for 10 seconds. No visible damage and cutting off.
9	Load test	Rated 3.6 voltage and 2700HZ is applied for 96 hours

**TEST CONDITION.**

Standard Test Condition	:	a) Temperature : +5 ~ +35°C	b) Humidity : 45-85%	c) Pressure : 860-1060mbar
一般测试条件	:	a) 温度 : +5 ~ +35°C	b) 湿度 : 45-85%	c) 气压 : 860-1060mbar
Judgment Test Condition	:	a) Temperature : +25 ± 2°C	b) Humidity : 60-70%	c) Pressure : 860-1060mbar
争议时测试条件	:	a) 温度 : +25 ± 2°C	b) 湿度 : 60-70%	c) 气压 : 860-1060mbar

# I. PACKING STANDARD

Specifications

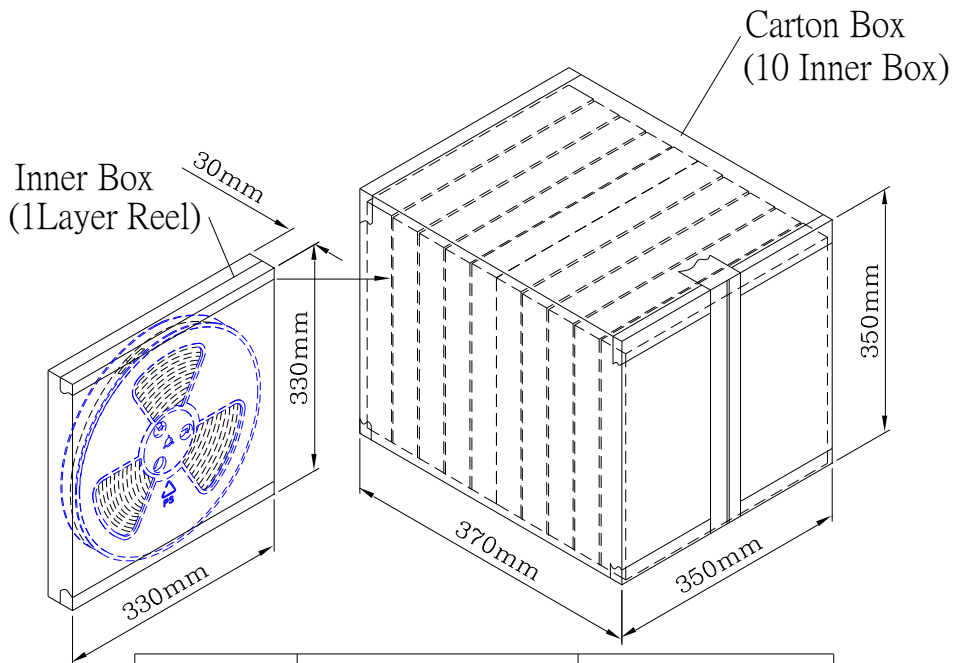
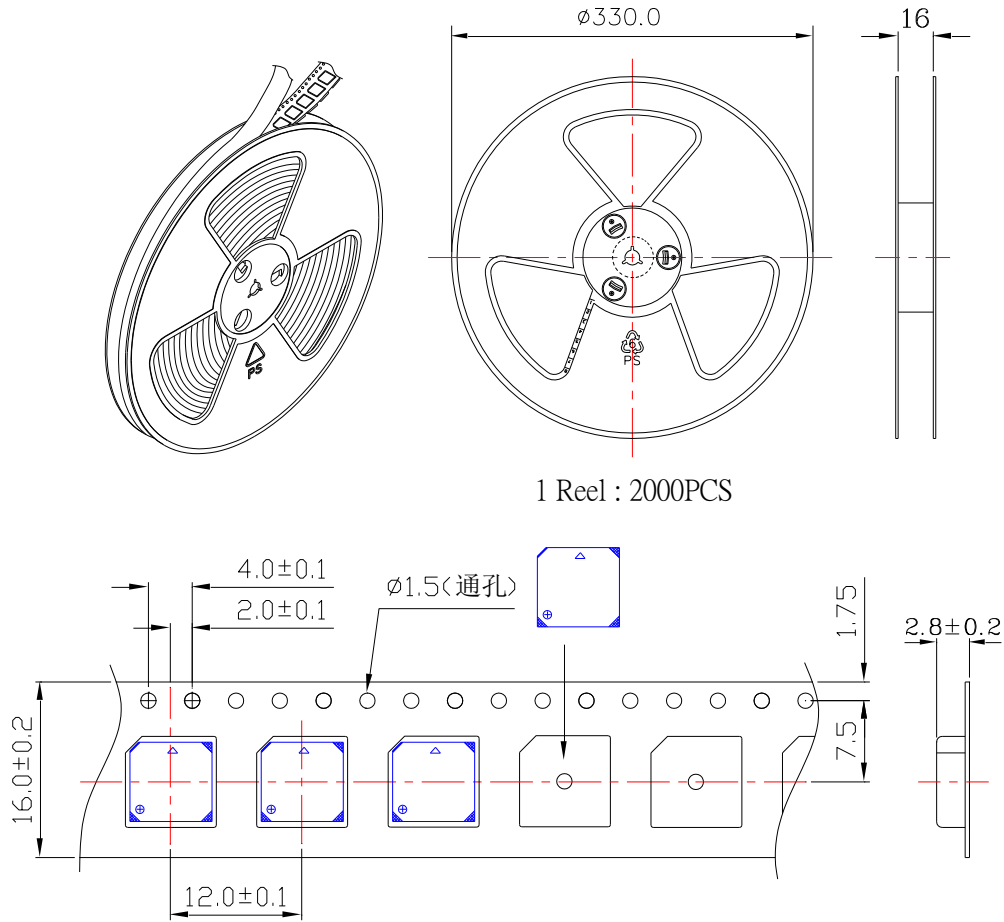

Inner Box	330mmx330mmx30mm	1x2000PCS=2000PCS
Carton Box	350mmx350mmx370mm	10x2000PCS=20,000PCS