

P.C.B. HOLE DRILLINGS
(P.C.B. TOP SIDE)

(5 : 1)

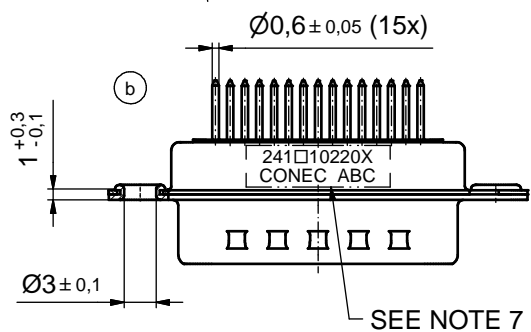
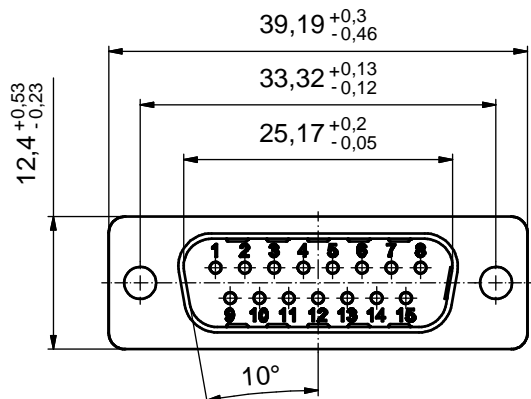
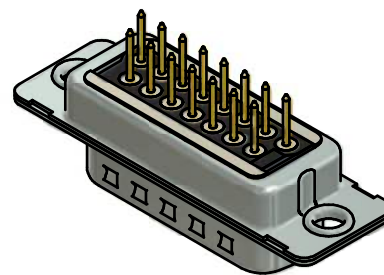
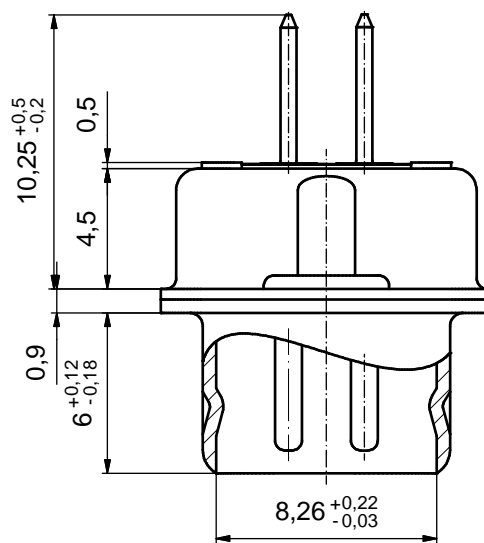

SEE NOTE 7

NOTES: (b)

- FOR WAVESOLDERING (SOLDER BATH TEMPERATURE 260°C FOR 5 SEC. AND SOLDER PREHEAT 100°C FOR 30 SEC.)
- METALSHIELDS: STEEL; min. 315µm TIN over 40-80µm NICKEL
- INSULATOR: HIGH TEMPERATURE PLASTIC UL 94 V-0, BLACK
- CONTACTS: COPPER ALLOY; PLATING (SEE PART NO.):
 - PLEASE ADD A for GOLD FLASH over NICKEL (PREFERRED TYPE)
 - PLEASE ADD B for 20µm HARD GOLD over min. 50µm NICKEL
 - PLEASE ADD C for 30µm HARD GOLD over min. 50µm NICKEL
- DIELECTRIC WITHSTANDING VOLTAGE: 424 VDC
- CAPACITANCE: 370pF ± 20%
- CONNECTOR IS PART MARKED: 241□10020X CONEC ABC (see note 4)

Directive 2002/95/EC RoHS compliant

THIS DRAWING MAY NOT BE COPIED OR REPRODUCED IN ANY WAY, AND MAY NOT BE PASSED ON TO A THIRD PARTY WITHOUT WRITTEN PERMISSION. OWNERSHIP AND COPYRIGHT OF CONEC GmbH DO NOT ALTER CAD DRAWING BY HAND				tolerance		scale: 2:1 (5:1)
				dim. in mm		material: SEE NOTES
				date	name	title:
				drawn 07.05.2014	Heinrich	D-SUB C-FILTER MALE 15pos. SOLDER PIN STRAIGHT
				appd. 07.05.2014	Henneboel	
			norm		dwg no:	
			d-old	24K1A279/24K2A279	DIN-A3	
4 x b	A5200	07.05.2014	Heinrich		(b) 24K1A1525	sh: 1
rev.	description	date	name		part no: (b) 241□10020X (see note 4)	