

### Description

The [SPX2954](#) and [SPX2954A](#) are low power voltage regulators. These devices are an excellent choice for use in battery-powered applications such as cordless telephones, radio control systems, and portable computers. The SPX2954 and SPX2954A feature low quiescent current and low dropout voltage (typ. 20mV at 100μA and 310mV at 250mA). This includes a tight initial tolerance (0.5% for SPX2954A), extremely good load and line regulation (0.05% typ.), and very low output temperature coefficient (20 ppm/°C typ.), making the SPX2954/SPX2954A useful as a low-power voltage reference.

The error flag output feature is used as a power-on reset for warning of a low output voltage, due to a falling input voltage. The logic-compatible shutdown feature enables the regulator to be switched ON and OFF. The SPX2954/SPX2954A is offered in a 3-pin SOT-223 package and an 8-pin SOIC package.

### FEATURES

- 5.0V and 3.3V versions at 250mA output
- Accurate 0.5% for SPX2954A
- Very low quiescent current
- Low dropout: 310mV at 250mA
- Extremely tight load and line regulation
- Very low temperature coefficient
- Current and thermal limiting
- Need only 1μF for stability
- Direct replacement for LP2954
- Error flag warns of output dropout
- Logic-controlled electronic shutdown
- Programmable output from 1.24V to 30V

### Typical Application

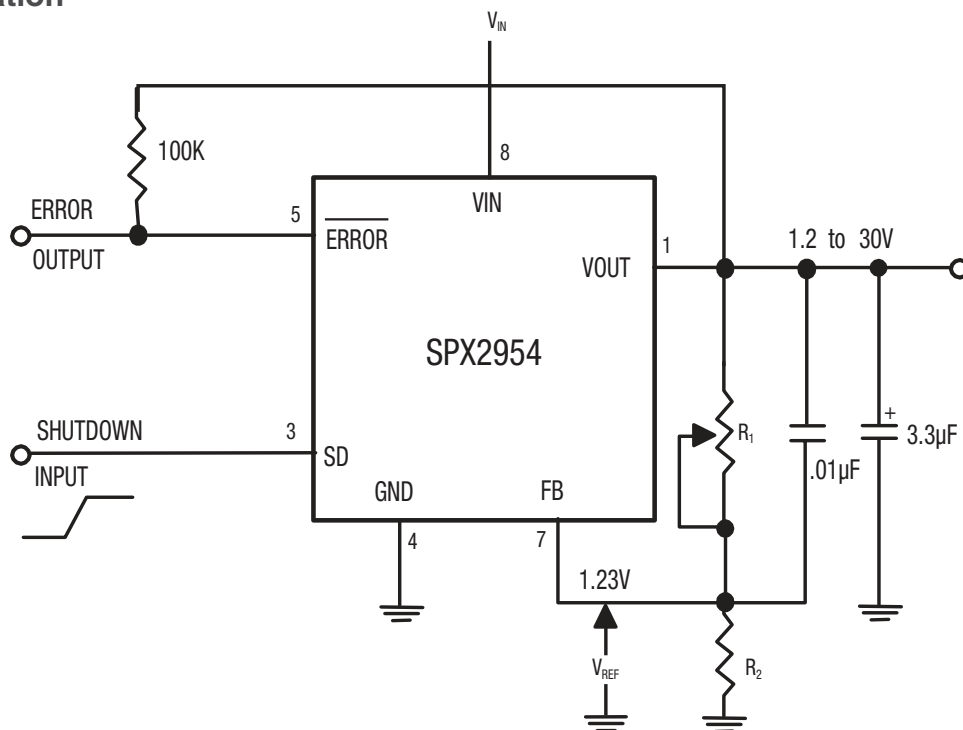

Typical Application

### Absolute Maximum Ratings

Stresses beyond the limits listed below may cause permanent damage to the device. Exposure to any Absolute Maximum Rating condition for extended periods may affect device reliability and lifetime.

Power Dissipation..... Internally Limited  
Lead Temperature (soldering, 5 seconds)..... 260°C  
Storage Temperature ..... -65°C to 150°C  
Operating Junction Temperature Range ..... -40°C to 125°C  
Input Supply Voltage ..... -0.3V to 30V

Feedback Input Voltage..... -1.5V to 30V  
Shutdown Input Voltage ..... -0.3V to 30V  
Error Comparator Voltage ..... -0.3V to 30V  
ESD Rating..... 2kV Min

**Electrical Characteristics**

Unless otherwise noted:  $V_{IN} = V_O + 1V$ ,  $I_L = 100\mu A$ ,  $C_L = 1\mu F^{(2)}$   $T_A = 25^\circ C$ .

Parameter	Conditions	SPX2954A			SPX2954			Units
		Min	Typ	Max	Min	Typ	Max	
<b>3.3V Versions</b>								
Output Voltage	$T_J = 25^\circ C$	3.284	3.3	3.317	3.267	3.3	3.333	V
	$-25^\circ C \leq T_J \leq 85^\circ C$	3.267	3.3	3.333	3.251	3.3	3.350	
	Full Operating Temp.	3.260	3.3	3.340	3.234	3.3	3.366	
Output Voltage	$100\mu A \leq I_L \leq 250mA$ ; $T_J \leq T_{MAX}$	<b>3.251</b>	<b>3.3</b>	<b>3.350</b>	<b>3.201</b>	<b>3.3</b>	<b>3.399</b>	V
<b>5V Versions</b>								
Output Voltage	$T_J = 25^\circ C$	4.975	5.0	5.025	4.950	5.0	5.050	V
	$-25^\circ C \leq T_J \leq 85^\circ C$	4.950	5.0	5.050	4.925	5.0	5.075	
	Full Operating Temp.	4.940	5.0	5.060	4.900	5.0	5.100	
Output Voltage	$100\mu A \leq I_L \leq 250mA$ ; $T_J \leq T_{MAX}$	<b>4.925</b>	<b>5.0</b>	<b>5.075</b>	<b>4.850</b>	<b>5.0</b>	<b>5.150</b>	V
<b>All Voltage Options</b>								
Output Voltage Temperature Coefficient <sup>(1)</sup>			20	100		50	150	ppm/ $^\circ C$
Line Regulation <sup>(3)</sup>	$V_O + 1V \leq V_{IN} \leq 30V$ ; $I^{(4)}$		0.03	0.10		0.04	0.20	%
Load Regulation <sup>(3)</sup>	$100\mu A \leq I_L \leq 250mA$		0.04	0.20		0.10	0.30	%
Dropout Voltage <sup>(5)</sup>	$I_L = 1mA$		60	100		60	100	mV
	$I_L = 100mA$		290	450		290	450	
	$I_L = 250mA$		310	500		310	500	
Ground Current	$I_L = 1mA$		150	170		150	170	$\mu A$
	$I_L = 100mA$		3	6		3	6	mA
	$I_L = 250mA$		10	14		10	14	
Current Limit	$V_{OUT} = 0$		270	550		270	550	mA
Thermal Regulation Output Noise, 10Hz to 100kHz			0.05	0.2		0.05	0.2	%/W
	$C_L = 1\mu F$		430			430		$\mu V_{rms}$
	$C_L = 200\mu F$		160			160		$\mu V_{rms}$
	$C_L = 3.3\mu F$ , Bypass = $0.01\mu F$ from pin 7 to Pin 1 (8 pin versions)		100			100		$\mu V_{rms}$
<b>8-Pin Version Only</b>								
Reference Voltage		1.220	1.235	1.250	1.210	1.235	1.260	V
	Over Temp <sup>(6)</sup>	1.190		2.270	1.185		1.285	V
Feedback Pin Bias Current			40	60		40	60	nA
Vref Temperature Coefficient			20			50		ppm/ $^\circ C$
Feedback $I_{BIAS}$ Temperature Coefficient			0.1			0.1		nA/ $^\circ C$

Parameter	Conditions	SPX2954A			SPX2954			Units
		Min	Typ	Max	Min	Typ	Max	
Error Comparator								
Output Leakage Current	$V_{OH} = 30V$		0.01	1		0.01	1	$\mu A$
Output Low Voltage	$V_{IN} = V_O - 0.5V; I_{OL} = 400\mu A$		150	250		150	250	mA
Upper Threshold Voltage <sup>(7)</sup>		40	60		40	60		mA
Lower Threshold Voltage <sup>(7)</sup>			75	95		75	95	mV
Hysteresis <sup>(7)</sup>			15			15		mV
Shutdown								
Input Logic Voltage	Low (Regulator ON)		1.3	0.7		1.3	0.7	V
	High (Regulator OFF)	2.0			2.0			
Shutdown Input Current	$V_S = 2.4V$		30	50		30	50	$\mu A$
	$V_S = 30V$		400	800		400	800	
Regulator Output Current in Shutdown <sup>(8)</sup>			3	10		3	10	$\mu A$
Thermal Resistance $\Theta_{JA}$								
SOIC-8			128.4					$^{\circ}C/W$
SOT-223			62.3					$^{\circ}C/W$

**NOTES:**

1. Output or reference voltage temperature coefficients defined as the worst case voltage change divided by the total temperature range.
2. Unless otherwise specified all limits guaranteed for  $T_J = 25^{\circ}C$ ,  $V_{IN} = 6V$ ,  $I_L = 100\mu A$  and  $C_L = 1\mu F$ . Additional conditions for the 8-pin versions are feedback tied to 5V tap and output tied to output sense ( $V_{OUT} = 5V$ ) and  $V_{SHUTDOWN} \leq 0.8V$ .
3. Regulation is measured at constant junction temperature, using pulse testing with a low duty cycle. Changes in output voltage due to heating effects are covered under the specification for thermal regulation.
4. Line regulation for the SPX2954 is tested at  $I_L = 1mA$ .
5. Dropout voltage is defined as the input to output differential at which the output voltage drops 100mV below its nominal value measured at 1V differential. At very low values of programmed output voltage, the minimum input supply voltage of 2V (2.3V over temperature) must be taken into account.
6.  $V_{REF} \leq V_{OUT} \leq (V_{IN} - 1V)$ ,  $2.3 \leq V_{IN} \leq 30V$ ,  $100\mu A \leq I_L \leq 250mA$ ,  $T_J \leq T_{JMAX}$ .
7. Comparator thresholds are expressed in terms of a voltage differential at the feedback terminal below the nominal reference voltage measured at 6V input. To express these thresholds in terms of output voltage change, multiply by the error amplifier gain =  $V_{OUT}/V_{REF} = (R1 + R2)/R2$ . For example, at a programmed output voltage of 5V, the error output is guaranteed to go low when the output drops by  $95mV \times 5V/1.235 = 384mV$ . Thresholds remain constant as a percent of  $V_{OUT}$  as  $V_{OUT}$  is varied, with the dropout warning occurring at typically 5% below nominal, 7.5% guaranteed.
8.  $V_{SHUTDOWN} \geq 2V$ ,  $V_{IN} \leq 30V$ ,  $V_{OUT} = 0$ , Feedback pin tied to 5V/3.3V Tap.

**Pin Configurations**

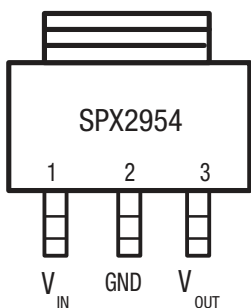

Front View

SOT-223 Package (M3)

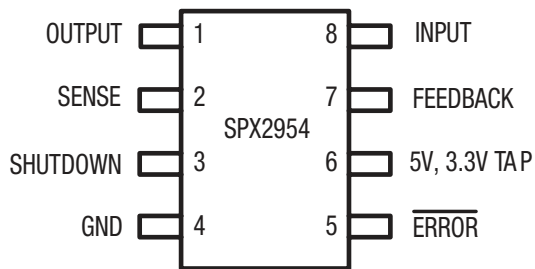

Top View

8-Pin Surface Mount (S)

### Functional Block Diagram

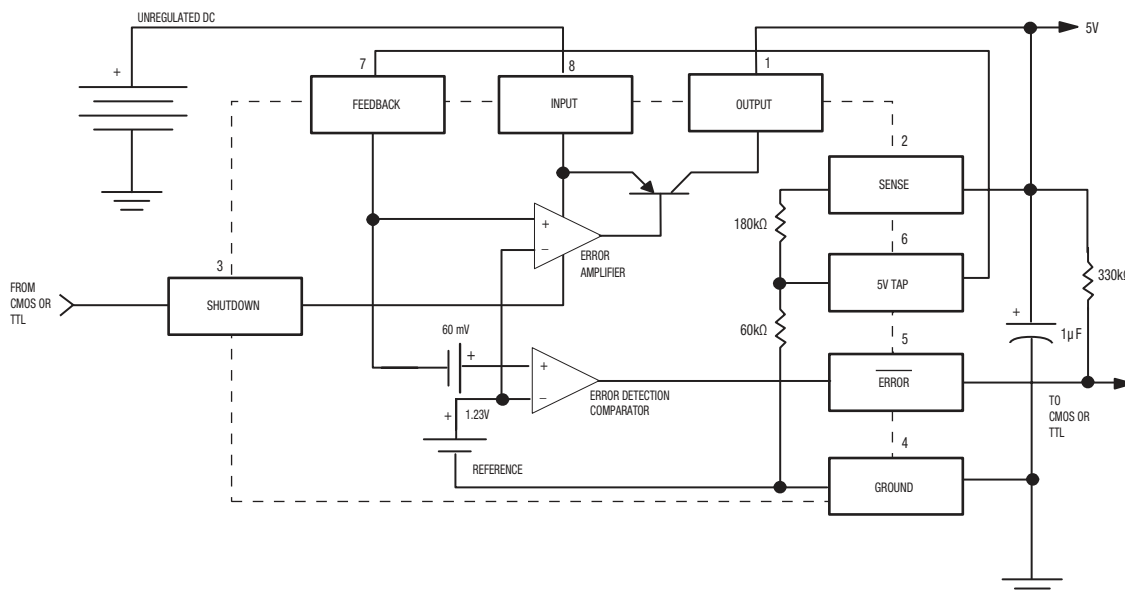

SPX2954 Block Diagram, 8-Lead 5V Version

### Typical Performance Characteristics

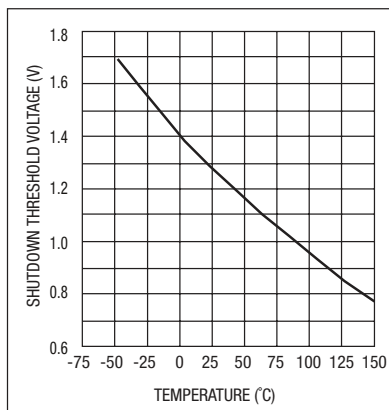

Shutdown Threshold Voltage

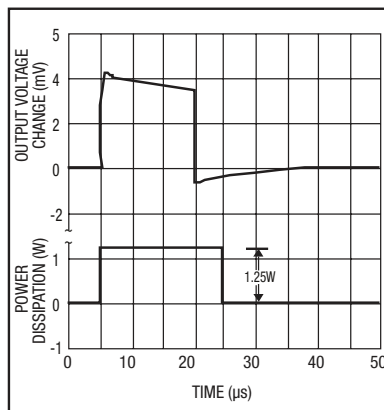

Thermal Response

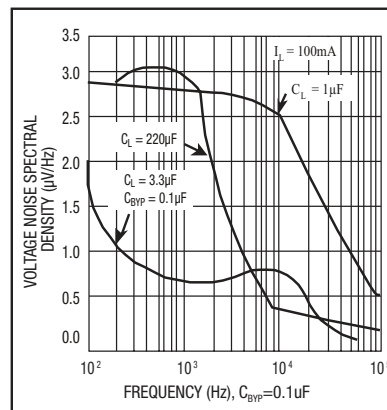

Output Noise

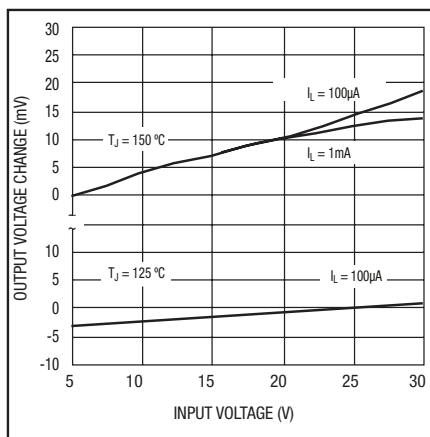

Line Regulation

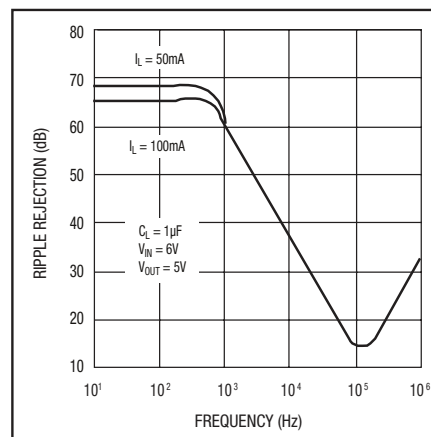

Ripple Rejection

Typical Performance Characteristics (Continued)

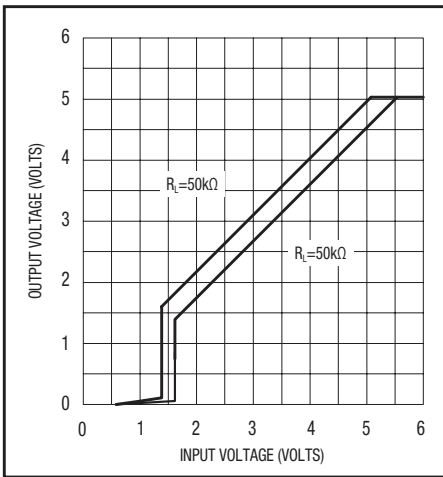

Dropout Characteristics

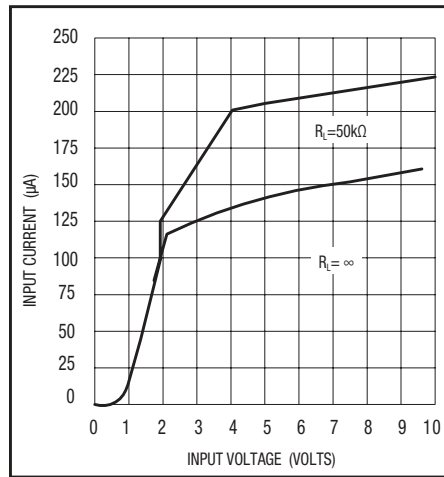

Input Current

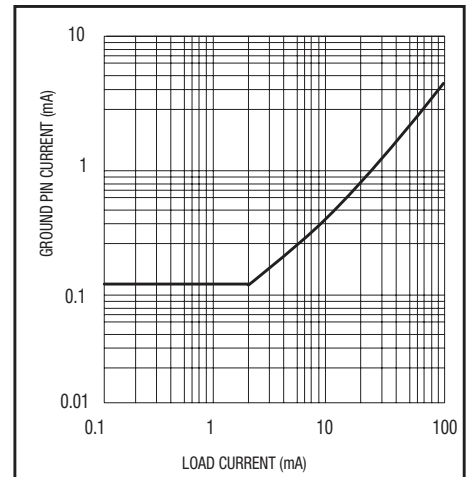

Quiescent Current

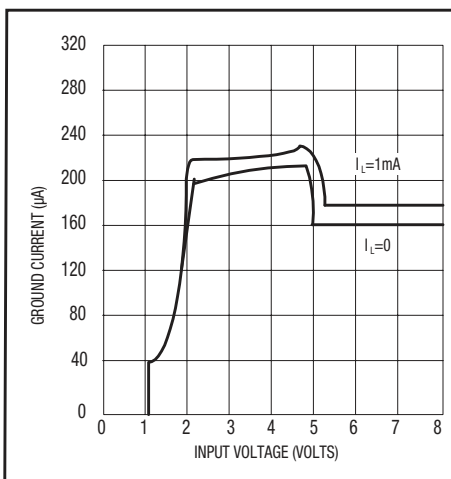

Ground Current

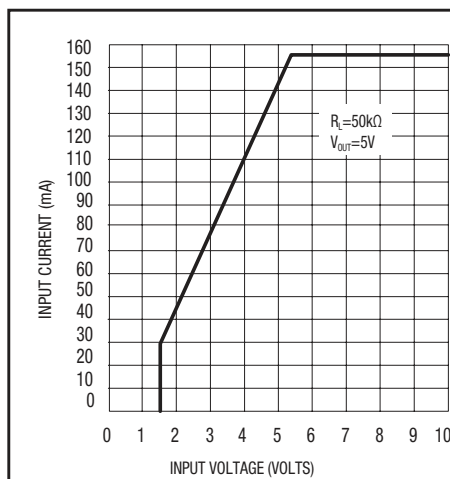

Input Current

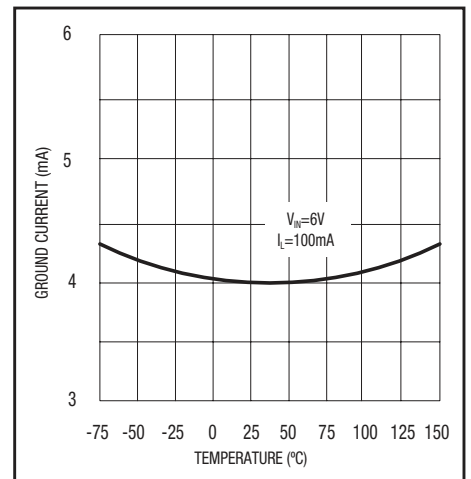

Ground Current

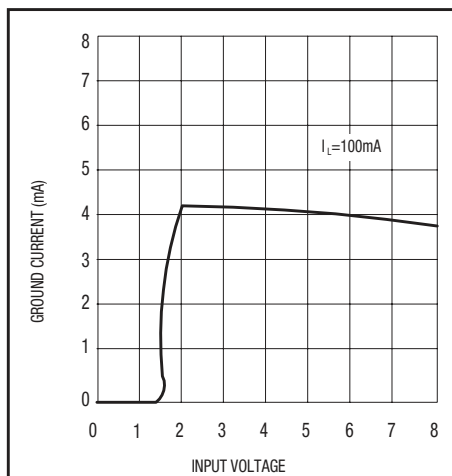

Ground Current

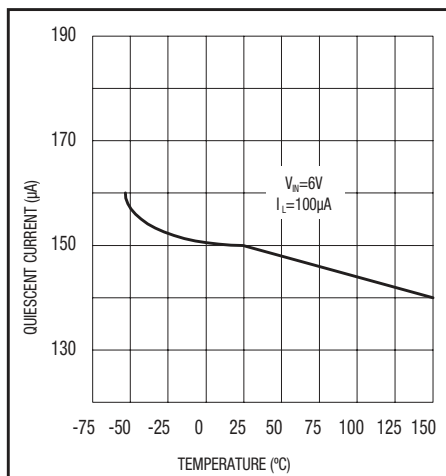

Quiescent Current

Typical Performance Characteristics (Continued)

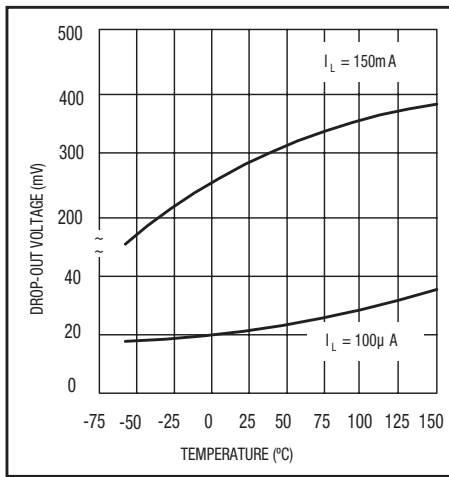

Drop-Out Voltage

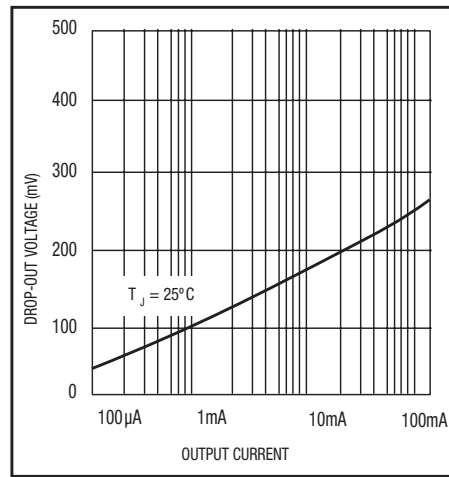

Drop-Out Voltage

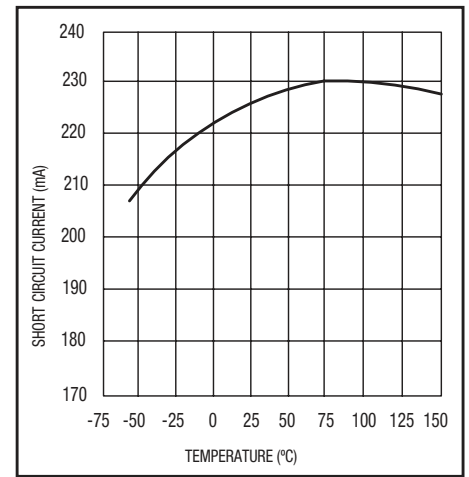

Short Circuit Current

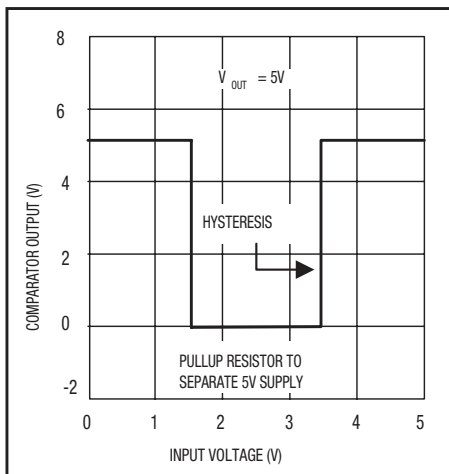

Error Comparator Output

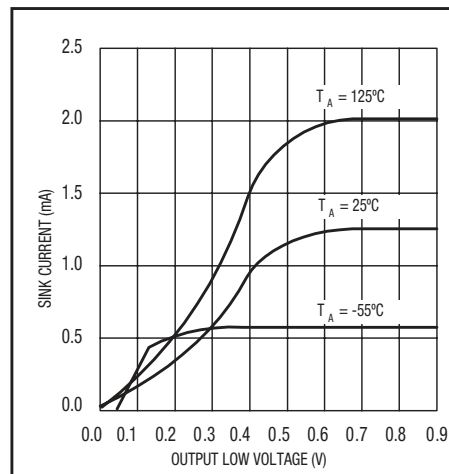

Comparator Sink Current

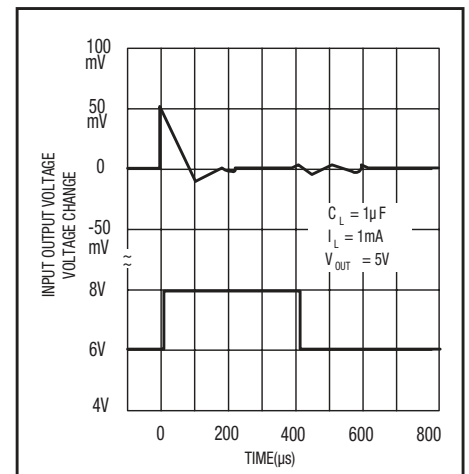

Line Transient Response

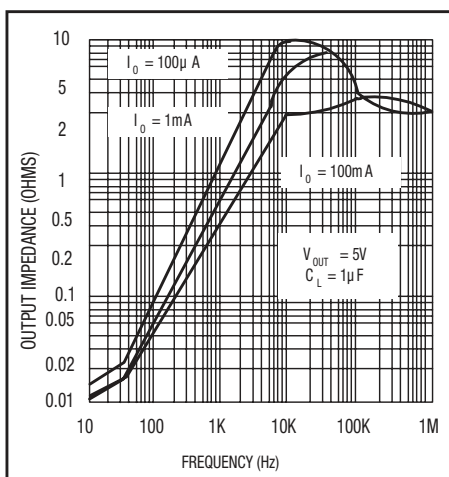

Output Impedance

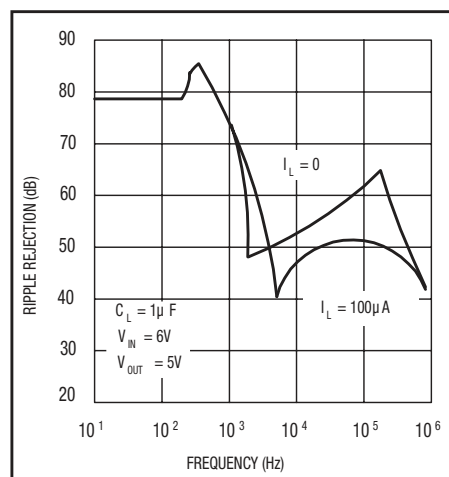

Ripple Rejection

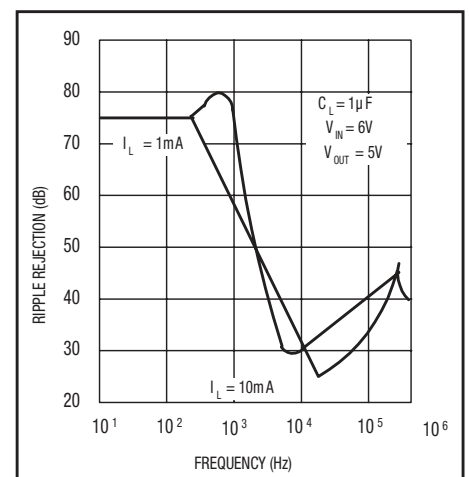

Ripple Rejection

Typical Performance Characteristics (Continued)

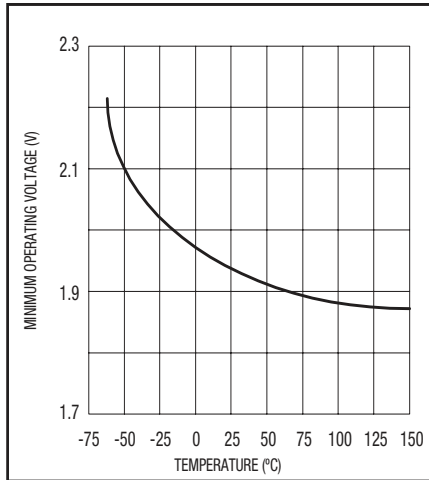

Minimum Operating Voltage

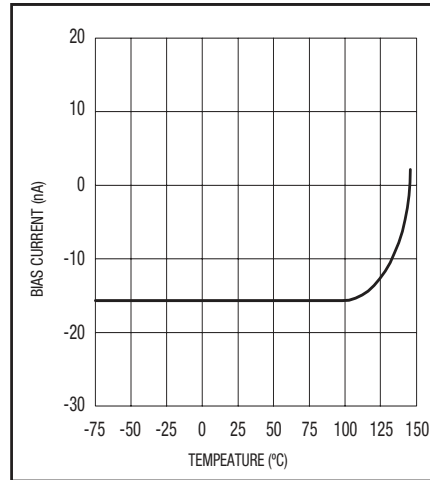

Feedback Bias Current

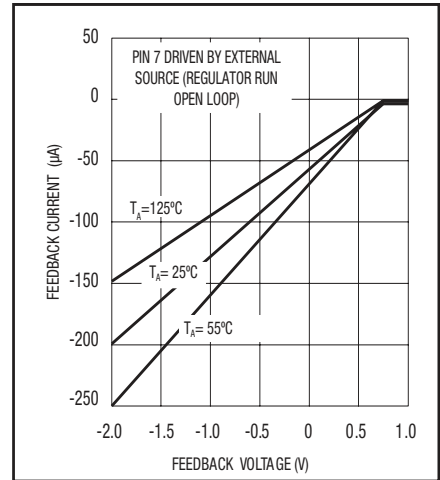

Feedback Pin Current

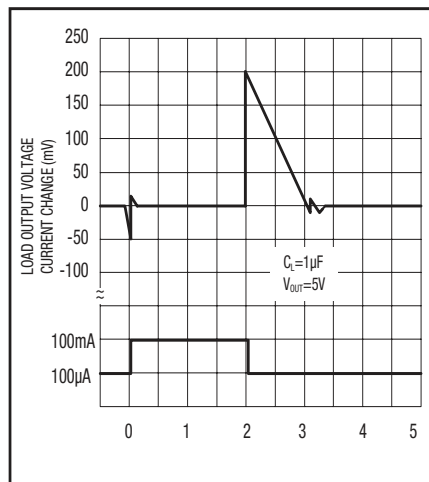

Load Transient Response

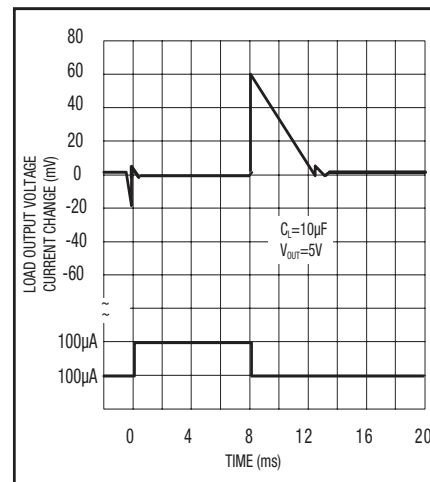

Load Transient Response

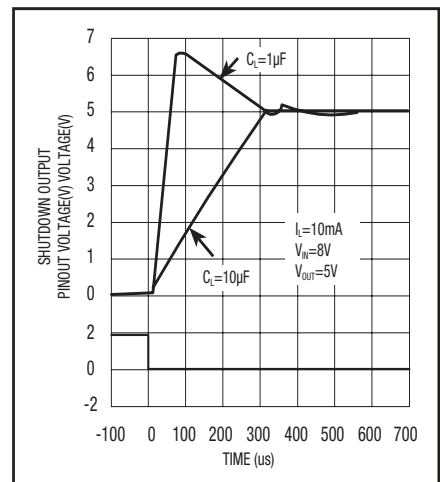

Enable Transient

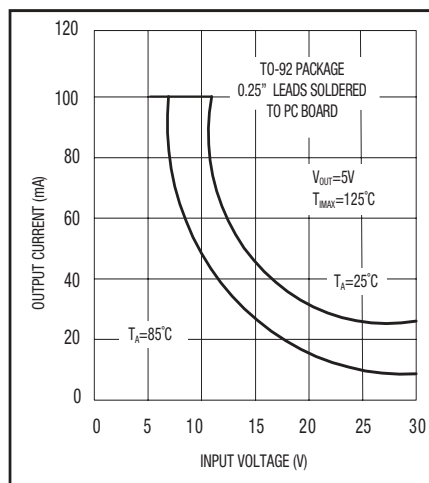

Maximum Rated Output

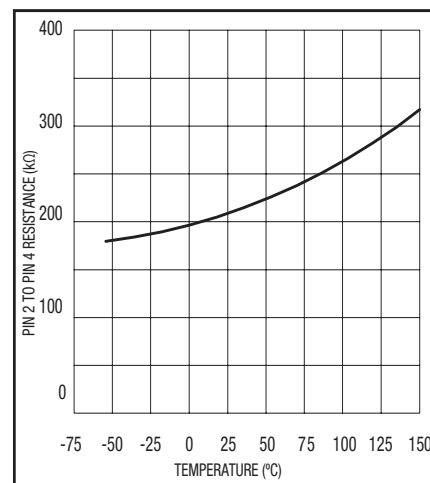

Divider Resistance

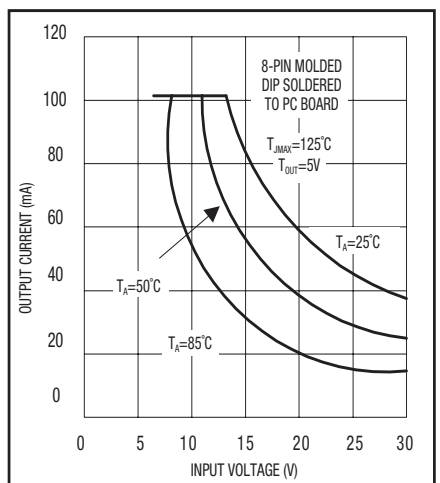

Maximum Rated Output Current



## Applications Information

### External Capacitors

The stability of the SPX2954 requires a 1 $\mu$ F or greater capacitor between output and ground. Oscillation could occur without this capacitor. Most types of tantalum or aluminum electrolytic works fine here. For operations below -25°C solid tantalum is recommended since the many aluminum types have electrolytes that freeze at about -30°C. The ESR of about 5 $\Omega$  or less and resonant frequency above 500kHz are the most important parameters in the value of the capacitor. The capacitors value may be increased without limit.

At lower values of output current, less output capacitance is required for stability. For the currents below 10mA the value of the capacitor can be reduced to 0.33 $\mu$ F and 0.1 $\mu$ F for 1mA. More output capacitance is needed for the 8-pin version at voltages below 5V since it runs the error amplifier at lower gain. At worst case 3.3 $\mu$ F or greater must be used for the condition of 150mA load at 1.23V output.

The SPX2954 unlike other low dropout regulators will remain stable and in regulation with no load in addition to the internal voltage divider. This feature is especially important in applications like CMOS RAM keep-alive. When setting the output voltage of the SPX2954 version with external resistors, a minimum load of 1 $\mu$ A is recommended.

If there is more than 10 inches of wire between the input and the AC filter capacitor or if a battery is used as the input then a 1 $\mu$ F tantalum or aluminum electrolytic capacitor should be placed from the input to the ground.

Instability can occur if there is stray capacitance to the SPX2954 feedback terminal (pin 7). This could cause more problems when using a higher value of external resistors to set the output voltage. This problem can be fixed by adding a 100pF capacitor between output and feedback and increasing the output capacitor to at least 3.3 $\mu$ F.

### Error Detection Comparator Output

The comparator produces a logic low output whenever the SPX2954 output falls out of regulation by more than around 5%. This is around 60mV offset divided by the 1.235 reference voltage. This trip level remains 5% below normal regardless of the programmed output voltage of the regulator.

Figure 1 shows the timing diagram depicting the ERROR signal and the regulator output voltage as the SPX2954 input is ramped up and down. The ERROR signal becomes low at around 1.3V input, and goes high around 5V input (input voltage at which  $V_{OUT} = 4.75$ ). Since the SPX2954's dropout voltage is load dependent, the input voltage trip point (around 5V) will vary with the load current. The output voltage trip point (approx. 4.75V) does not vary with load.

The error comparator has an open-collector output, which requires an external pull-up resistor. Depending on the system requirements the resistor may be returned to 5V output or other supply voltage. In determining the value of this resistor, note that the output is rated to sink 400mA, this value adds to battery drain in a low battery condition. Suggested values range from 100k to 1M $\Omega$ . If the output is unused this resistor is not required.

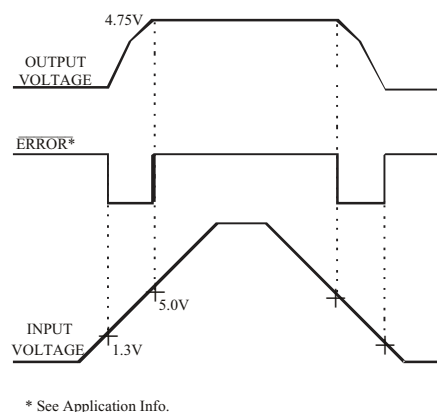

\* See Application Info.

Figure 1. Error Output Timing

### Programming the Output Voltage of SPX2954

The SPX2954 may be pin-strapped for 5V using its internal voltage divider by tying Pin 1 (output) to Pin 2 (sense) and Pin 7 (feedback) to Pin 6 (5V Tap). Also, it may be programmed for any output voltage between its 1.235V reference and its 30V maximum rating using an external pair of resistors. Refer to the below equation for the programming of the output voltage:

$$V_{OUT} = V_{REF} \times (1 + R_1/R_2) + I_{FB} R_1$$

The  $V_{REF}$  is 1.235 and  $I_{FB}$  is the feedback bias current, nominally -20nA. The minimum recommended load current of 1 $\mu$ A forces an upper limit of 1.2M $\Omega$  on value of  $R_2$ . If no load is presented the  $I_{FB}$  produces an error of typically 2% in  $V_{OUT}$  which may be eliminated at room temperature by trimming  $R_1$ . To improve the accuracy choose the value of  $R_2 = 100k$  this reduces the error by 0.17% and increases the resistor program current by 12 $\mu$ A. Since the SPX2954 typically draws 60 $\mu$ A at no load with Pin 2 open-circuited, this is a small price to pay.

**Reducing Output Noise**

It may be an advantage to reduce the AC noise present at the output. One way is to reduce the regulator bandwidth by increasing the size of the output capacitor. This is the only way that noise can be reduced on the 3 lead SPX2954 but is relatively inefficient, as increasing the capacitor from 1μF to 220μF only decreases the noise from 430μV to 160μVRMS for a 100kHz bandwidth at 5V output. Noise can be reduced fourfold by using a bypass capacitor across R<sub>1</sub>, since it reduces the high frequency gain from 4 to unity. Pick

$$C_{\text{BYPASS}} \approx (1 / 2\pi R_1 \times 200\text{Hz})$$

or choose 0.01μF. When doing this, the output capacitor must be increased to 3.3μF to maintain stability. These changes reduce the output noise from 430μV to 100μVRMS for a 100kHz bandwidth at 5V output. With the bypass capacitor added, noise no longer scales with output voltage so that improvements are more dramatic at higher output voltages.

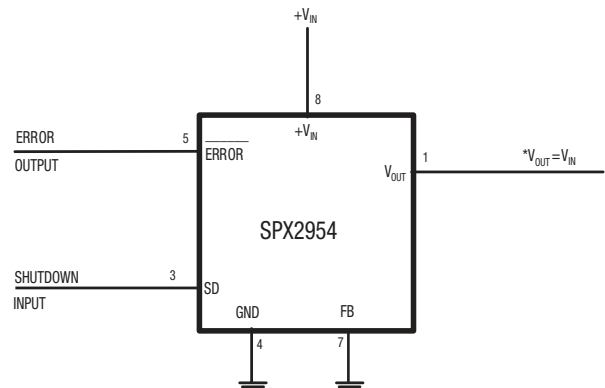

\*MINIMUM INPUT-OUTPUT VOLTAGE RANGES FROM 40mV to 400mV. DEPENDENT ON LOAD CURRENT.

Figure 3. Wide Input Voltage Range, Current Limiter

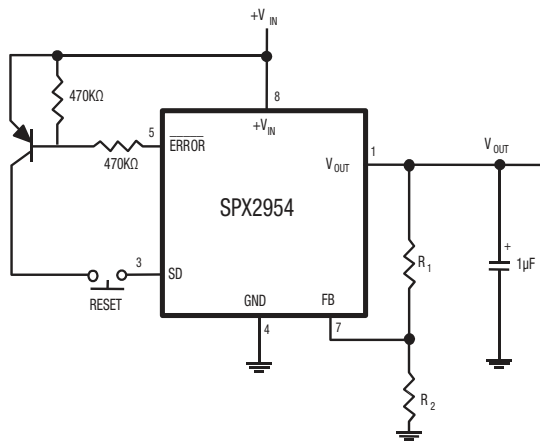

Figure 2. Latch Off when Error Flag Occurs

Applications Information (continued)

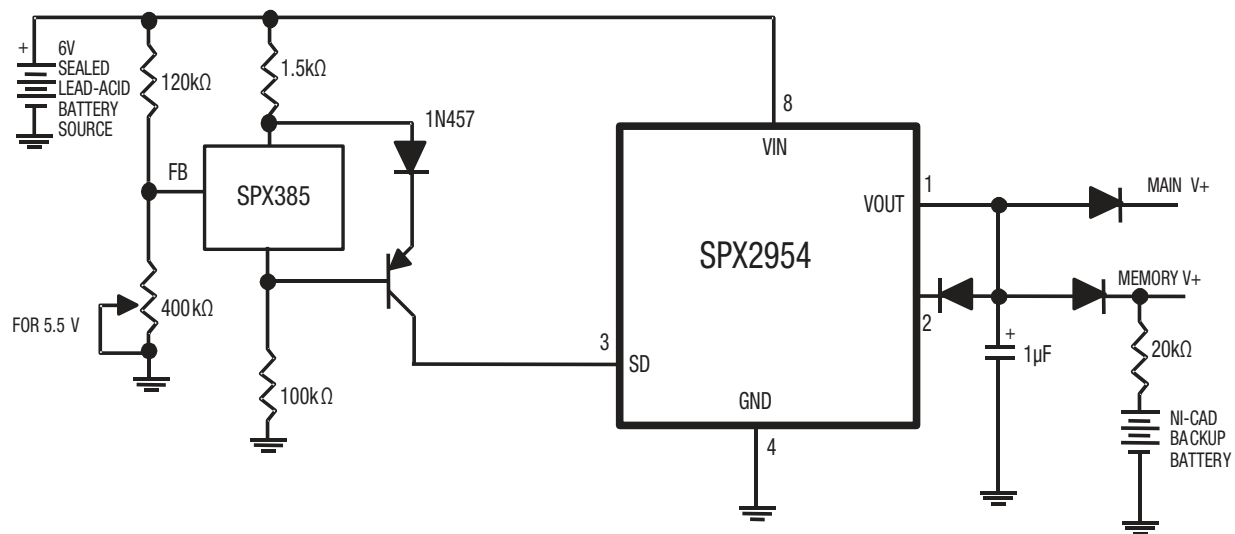

Figure 4. Low Battery Disconnect

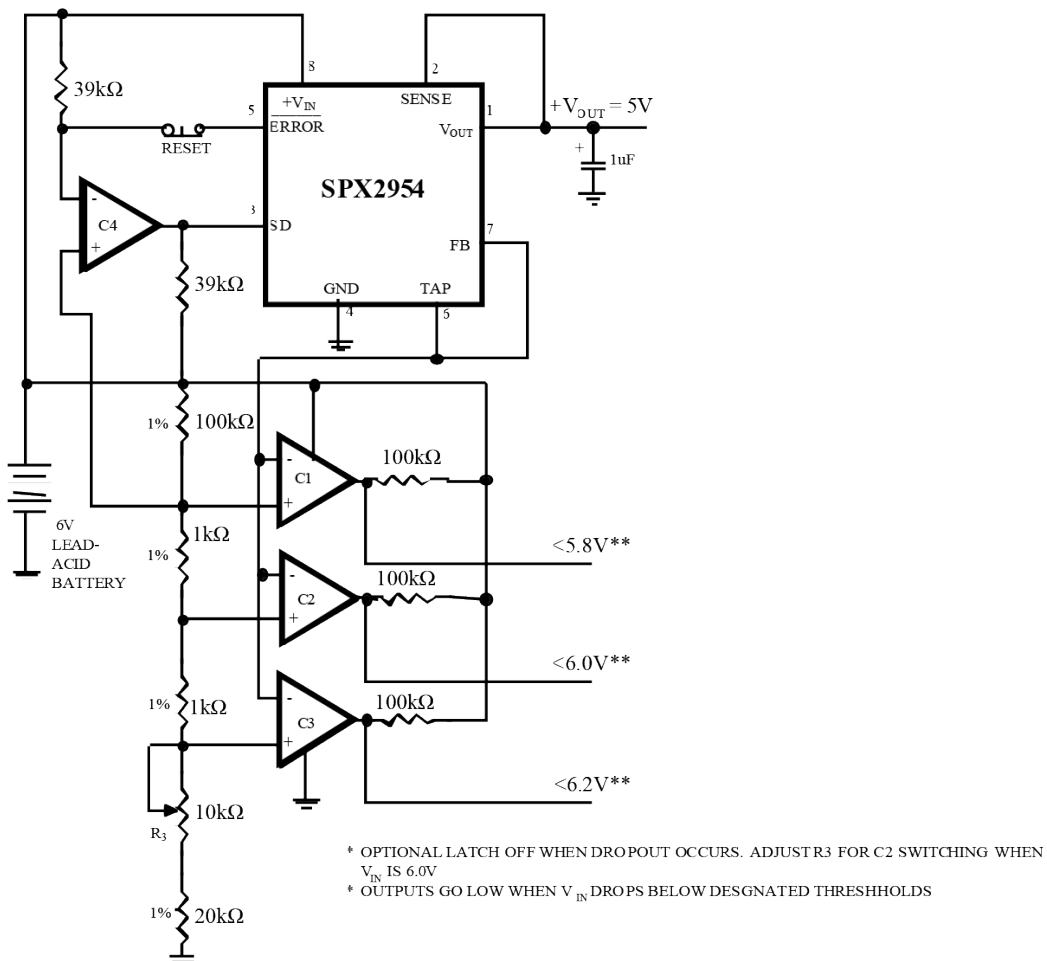

Figure 5. Regulator with State of Charge Indicator

Applications Information (continued)

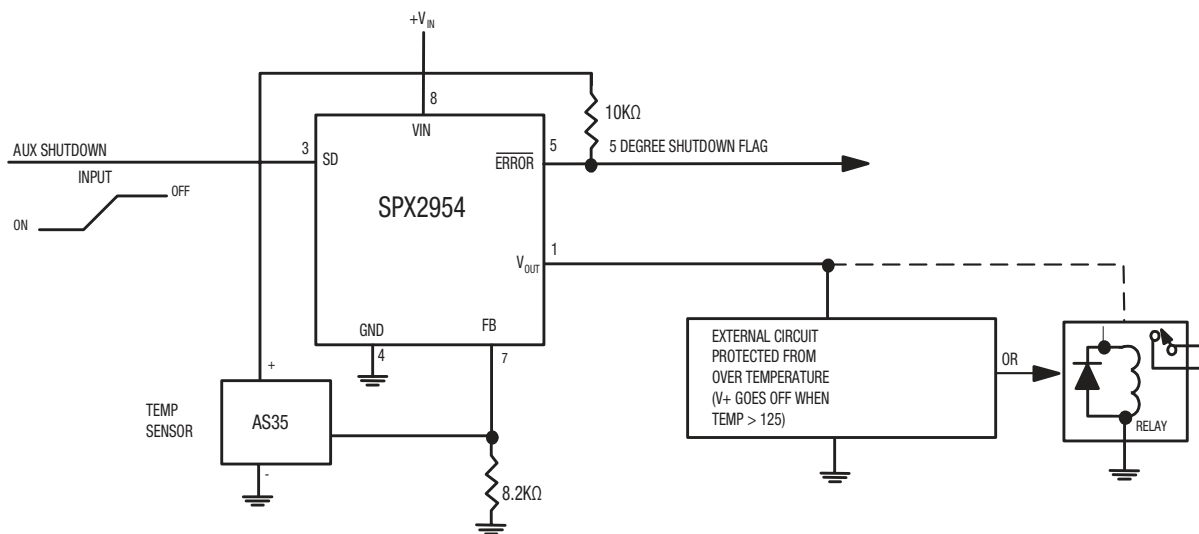

Figure 6. System Over Temperature Protection

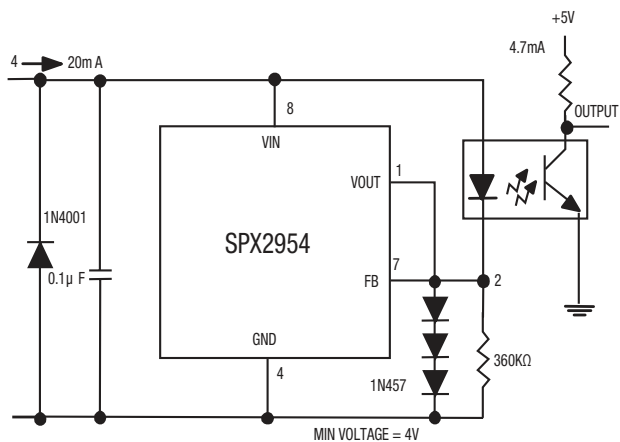

Figure 7. Open Circuit Detector for 4mA to 20mA Current Loop

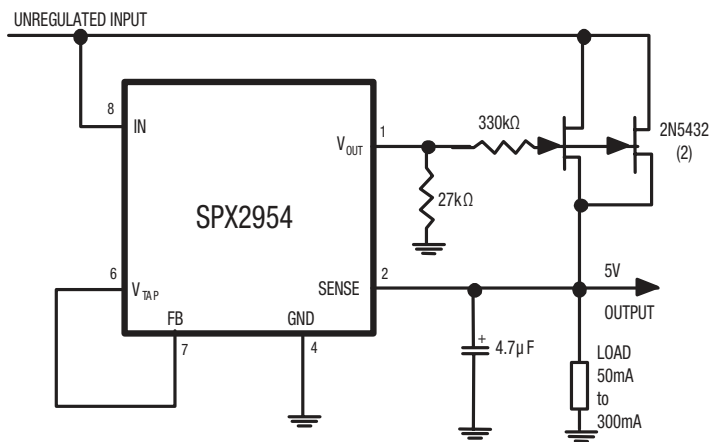
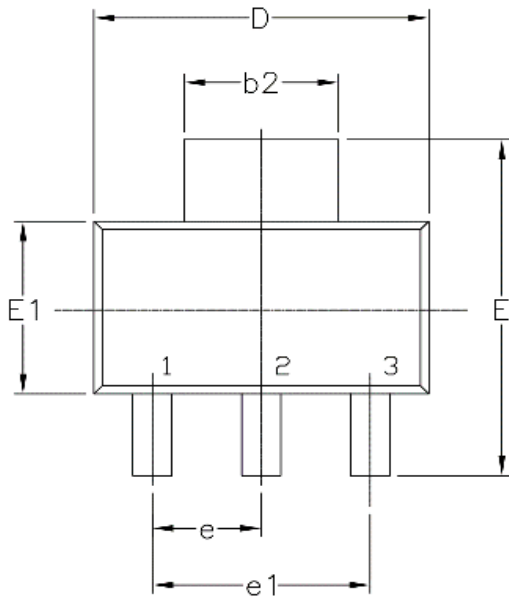

Figure 8. 300mA Regulator with 0.75V

Package Description

SOT-223-3



TOP VIEW

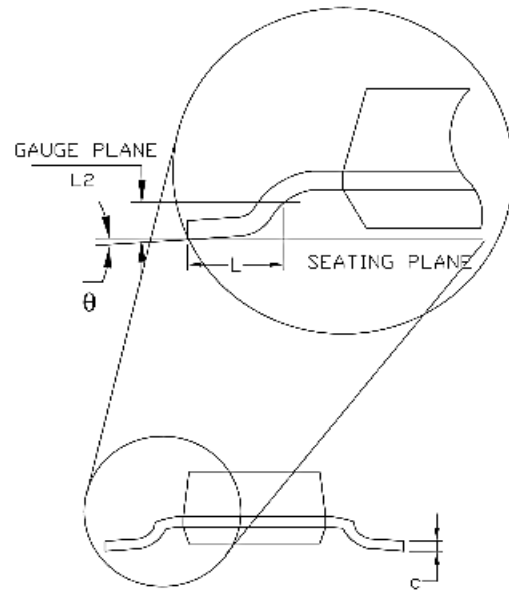

FRONT VIEW

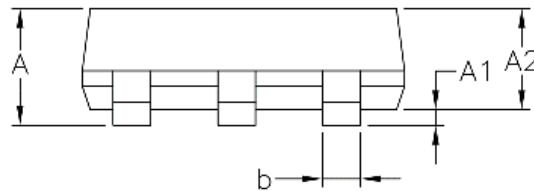

BOTTOM VIEW

3 Pin SOT-223 JEDEC TO-261 Variation AA						
SYMBOLS	DIMENSIONS IN MM (Control Unit)			DIMENSIONS IN INCH (Reference Unit)		
	MIN	NOM	MAX	MIN	NOM	MAX
A	—	—	1.80	—	—	0.071
A1	0.02	—	0.10	0.001	—	0.004
A2	1.50	1.60	1.70	0.060	0.063	0.067
b	0.66	0.76	0.84	0.026	0.030	0.033
b2	2.90	3.00	3.10	0.114	0.118	0.122
c	0.23	0.30	0.35	0.010	0.012	0.014
D	6.30	6.50	6.70	0.248	0.256	0.264
E	6.70	7.00	7.30	0.264	0.276	0.287
E1	3.30	3.50	3.70	0.130	0.138	0.146
e	2.30 BSC			0.091 BSC		
e1	4.60 BSC			0.182 BSC		
L	0.75	—	—	0.030	—	—
L2	0.25 BSC			0.010 BSC		
θ	0°	—	10°	0°	—	10°
N	3			3		

TERMINAL DETAILS

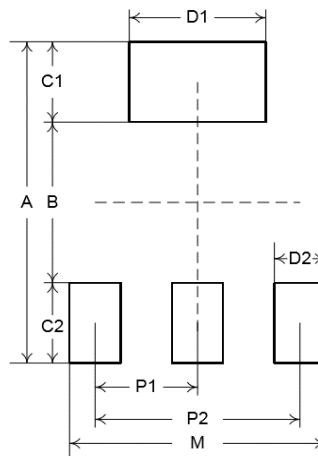

SYMBOLS	Footprint Dimension
A	8.0
B	4.0
C1	2.0
C2	2.0
D1	3.2
D2	1.2
M	5.8
P1	2.3
P2	4.6

TYPICAL RECOMMENDED LAND PATTERN

Drawing No. : POD-0000098

Revision: B

Package Description (Continued)

SOIC-8

Top View

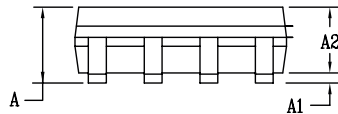
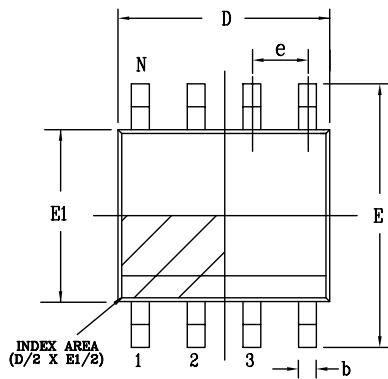

Side View

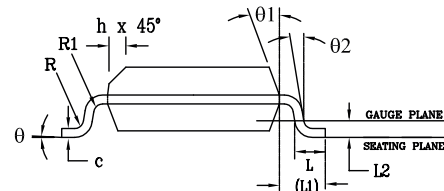

Front View

PACKAGE OUTLINE NSOIC .150" BODY JEDEC MS-012 VARIATION AA						
SYMBOLS	COMMON DIMENSIONS IN MM (Control Unit)			COMMON DIMENSIONS IN INCH (Reference Unit)		
	MIN	NOM	MAX	MIN	NOM	MAX
A	1.35	—	1.75	0.053	—	0.069
A1	0.10	—	0.25	0.004	—	0.010
A2	1.25	—	1.65	0.049	—	0.065
b	0.31	—	0.51	0.012	—	0.020
c	0.17	—	0.25	0.007	—	0.010
E	6.00 BSC			0.236 BSC		
E1	3.90 BSC			0.154 BSC		
e	1.27 BSC			0.050 BSC		
h	0.25	—	0.50	0.010	—	0.020
L	0.40	—	1.27	0.016	—	0.050
L1	1.04 REF			0.041 REF		
L2	0.25 BSC			0.010 BSC		
R	0.07	—	—	0.003	—	—
R1	0.07	—	—	0.003	—	—
q	0°	—	8°	0°	—	8°
q1	5°	—	15°	5°	—	15°
q2	0°	—	—	0°	—	—
D	4.90 BSC			0.193 BSC		
N	8			8		

Drawing No: POD-00000108

Revision: A

Ordering Information<sup>(1)</sup>

Part Number	Operating Temperature Range	Lead-Free	Package	Packaging Method	Accuracy	Output Voltage (V)
SPX2954AM3-L-5-0/TR	-40°C ≤ T <sub>J</sub> ≤ 125°C	Yes <sup>(2)</sup>	SOT-223-3	Reel	0.5%	5.0
SPX2954M3-L-3-3/TR				Reel	1%	3.3
SPX2954M3-L-5-0/TR				Reel	1%	5.0
SPX2954M3-L-3-3 <sup>(3)</sup>				Tube	1%	3.3
SPX2954AS-L-5-0/TR <sup>(3)</sup>			SOIC-8	Reel	0.5%	5.0

**NOTE:**

1. Refer to [www.exar.com/SPX2954](http://www.exar.com/SPX2954) for most up-to-date Ordering Information.
2. Visit [www.exar.com](http://www.exar.com) for additional information on Environmental Rating.
3. NRND - Not Recommended for New Design.
4. TO-220, TO-92, and TO-263 package options no longer available.

## Revision History

Revision	Date	Description
1A	July 2017	Updated to Maxlinear logo. Updated format and ordering information table. Pin configurations moved to page 4. Removed information related to packages no longer available.



**Corporate Headquarters:**  
 5966 La Place Court  
 Suite 100  
 Carlsbad, CA 92008  
 Tel.: +1 (760) 692-0711  
 Fax: +1 (760) 444-8598  
[www.maxlinear.com](http://www.maxlinear.com)

**High Performance Analog:**  
 48720 Kato Road  
 Fremont, CA 94538  
 Tel.: +1 (510) 668-7000  
 Fax: +1 (510) 668-7001  
 Email: [powertechsupport@exar.com](mailto:powertechsupport@exar.com)  
[www.exar.com](http://www.exar.com)

The content of this document is furnished for informational use only, is subject to change without notice, and should not be construed as a commitment by MaxLinear, Inc.. MaxLinear, Inc. assumes no responsibility or liability for any errors or inaccuracies that may appear in the informational content contained in this guide. Complying with all applicable copyright laws is the responsibility of the user. Without limiting the rights under copyright, no part of this document may be reproduced into, stored in, or introduced into a retrieval system, or transmitted in any form or by any means (electronic, mechanical, photocopying, recording, or otherwise), or for any purpose, without the express written permission of MaxLinear, Inc.

Maxlinear, Inc. does not recommend the use of any of its products in life support applications where the failure or malfunction of the product can reasonably be expected to cause failure of the life support system or to significantly affect its safety or effectiveness. Products are not authorized for use in such applications unless MaxLinear, Inc. receives, in writing, assurances to its satisfaction that: (a) the risk of injury or damage has been minimized; (b) the user assumes all such risks; (c) potential liability of MaxLinear, Inc. is adequately protected under the circumstances.

MaxLinear, Inc. may have patents, patent applications, trademarks, copyrights, or other intellectual property rights covering subject matter in this document. Except as expressly provided in any written license agreement from MaxLinear, Inc., the furnishing of this document does not give you any license to these patents, trademarks, copyrights, or other intellectual property.

Company and product names may be registered trademarks or trademarks of the respective owners with which they are associated.

© 2017 MaxLinear, Inc. All rights reserved