

PART NUMBER	REVISION	DESCRIPTION	FEED TYPE
2151029-2	F	FINE CRIMP HEIGHT ADJUST	PNEUMATIC
7-2151029-2	F	PNEUMATIC AND CRIMP TOOLING KIT	PNEUMATIC
7-2151029-7	A	CRIMP TOOLING KIT	-

APPLICATOR DATA		
CRIMP WIRE	SIZE	TYPE
	.278 [7.06 mm]	D
INSUL	-	-
APPLICATOR INSTRUCTIONS 408-35042		

TERMINAL DATA: TE TERMINAL		TE CRIMP SPECIFICATION	
TERMINAL NAME: FULLY INSULATED FASTON			
WIRE STRIP LENGTH		INSULATION DIAMETER RANGE	
.296-.328 IN [7.52-8.33 mm]		∅ .320 [8.13mm] MAX	
TERMINAL APPLICATION SPECIFICATION	114-2123		
TERMINALS APPLIED			
TE TERMINAL	TE TERMINAL	TE TERMINAL	TE TERMINAL
4-520447-2	9-520447-2	4-521097-2	

WIRE SIZE	CRIMP HEIGHT INCH [mm]	CRIMP HEIGHT REFERENCE SETTING	∅ SOLDER
10	0.100+/-0.002 [2.54+/-0.05]	5.1	.25 IN [6.35mm]
12	0.095+/-0.002 [2.41+/-0.05]	6.3	.25 IN [6.35mm]



- RECOMMENDED SPARE PARTS
- REFER TO SUPPLIED INSTRUCTION SHEET FOR CLEANING, LUBRICATION AND STORAGE OF APPLICATOR.
- CRIMP HEIGHT REFERENCE SETTING WAS THE SETTING USED WHEN THE APPLICATOR WAS QUALIFIED AT THE FACTORY. ADJUSTMENT MAY BE NECESSARY WHEN RUNNING APPLICATOR IN THE FIELD.
- TO CONVERT THE APPLICATOR TO A NON-CARRIER CUTTING STYLE, REMOVE ITEM 13 AND ATTACH TO THE LOCATION ON THE BACK SIDE OF THE HOUSING. REFER TO INSTRUCTION SHEET FOR ADDITIONAL INFORMATION.
- ITEM 7 MUST BE REMOVED IF APPLICATOR IS USED ON BENCH MACHINE.
- ITEM 5 AND 9 ARE REQUIRED WHEN RUNNING ON A LEADMAKER. ITEM 42 REQUIRED WHEN RUNNING ON A BENCH MACHINE.
- FEED ADJUSTMENT MAY BE REQUIRED WHEN SWITCHING TERMINALS.
- TO CHECK CRIMP HEIGHT, CRIMP SOLDER (∅.25 IN [6.35mm] 60/40 SOLID CORE) AND MEASURE AT CENTER OF SLUG.
- IT MAY BE NECESSARY TO MODIFY THE T-TERMINATING/K-PRESS BASE PLATE BEFORE USE BY ADDING A 10-32 HOLE TO RELOCATE THE FORWARD STOP AS SHOWN.
- ITEMS 253 AND 255 MUST BE INSTALLED IN THE G-TERMINATING UNIT CHIP RELIEF HOLE BEFORE INSTALLING THE APPLICATOR.
- ITEM 257, REQUIRED IF APPLICATOR IS RUN ON T-TERMINATING UNIT/K-PRESS. GUARD, ITEM 256, REQUIRED IF APPLICATOR IS BEING USED ON G-TERMINATOR.
- TERMINAL PITCH NOT COMPATIBLE WITH MECHANICAL FEED.
- CONSULT PRODUCT ENGINEERING BEFORE USING 10AWG WIRE
- ITEMS NOT SHOWN.
- ITEM 261 REQUIRED WHEN APPLICATOR IS REMOVED FROM LEADMAKER AND PLACED IN AMP-O-LECTRIC TERMINATING UNIT.

ATLANTIC VERSION TERMINATOR INTERFACE ADAPTER

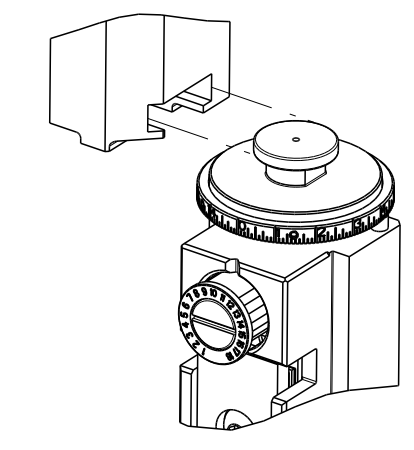

***WARNING**
ON INSTALLATION, SET WIRE DISC TO CRIMP HEIGHT REFERENCE SETTING FOR LARGEST WIRE SIZE. CRIMP HEIGHT REFERENCE SETTINGS GREATER THAN THE VALUE SHOWN MAY CAUSE DAMAGE TO THE CRIMP TOOLING, REFER TO THE INSTRUCTION SHEET FOR PROPER SETUP AND ADJUSTMENTS.

LOC	DIST	REVISIONS					
A	66	P	LYN	DESCRIPTION	DATE	DWN	APVD
		D		ECR-17-008076	05JUN2017	TB	GB
		E		ECR-18-017909	14NOV2018	JAH	CT
		F		ECR-19-005393	03APR2019	JAH	CT
		F1		ECR-22-146087	13JUL2022	JWC	GB

-	1	1	1-18023-1	SCR, SHC, M4x10	262	
-	1	1	803931-1	BRACKET, HOLD DOWN	261	
-	REF	REF	462992-5	GUARD ASSY	257	
-	REF	REF	679532-1	INSERT, GUARD	256	
-	1	1	189728-1	BRACKET, SPACER	255	
-	1	1	568681-1	SPACER, BASE PLATE	253	
-	1	1	2119641-1	FEED CAM, AIR FEED	248	
-	1	1	7-18023-7	SCR, SKT HD CAP M3 X 4.0	241	
-	1	1	2844940-2	AIR FEED MODULE	238	
-	1	1	1-18028-0	WASHER, FLAT, REG M8	192	
-	REF	REF	994970-2	COUNTER, MAGNETIC	164	
-	1	1	1-22281-8	SPRING, COMPRESSION	121	
-	1	1	2844908-1	SCREW, LOCKING	99	
-	1	1	2844907-1	POST, LOCKING	98	
-	1	1	1-690438-0	FRONT STRIP GUIDE	96	
-	6	6	2168083-1	SCR, SKT HD CAP, RoHS, M3 X 8.0	95	
-	1	1	2168083-6	SCR, SKT HD CAP, RoHS, M5 X 65	93	
-	1	1	455888-4	SPACER, CRIMPER	82	
-	1	1	240641-6	SPACER	81	
-	1	1	1803607-3	DOCUMENTATION PACKAGE	71	
-	1	1	2161332-2	DEPRESSOR, WIRE FUNNEL	70	
-	1	1	2161331-1	SPACER, WIRE FUNNEL DEPRESSOR	69	
-	2	2	1-18028-4	WASHER, FLAT, REG M3	68	
-	1	1	2119740-1	TAG, IDENTIFICATION	67	
-	2	2	2168078-1	SCREW, DRIVE, RH, RoHS, 2 x .188	66	
-	2	2	2-18032-5	SCR, SET, FLT PNT, M5 X 20.0	61	
-	1	1	2079383-4	SCR, BHSC, RoHS (M4 X 8)	60	
-	1	1	5-18022-5	SCR, HEX HD CAP, M4 X 6.0	59	
-	1	1	462427-2	FINGER, FEED	56	
-	4	4	2168400-1	SHCS, LOW HEAD, RoHS, M4 X 12	54	
-	2	2	2168083-9	SCR, SKT HD CAP, RoHS, M4 X 20	53	
-	1	1	18023-9	SCR, SKT HD CAP M4 X 6.0	49	
-	1	1	1-1803583-9	APPLICATOR BASIC ASSEMBLY, SF	46	
-	1	1	1803515-1	RAM ASSEMBLY, SF ATLANTIC	44	
-	1	1	462433-8	SUPPORT, INSULATION	42	
-	1	1	1803602-1	SCR, BHSC, RoHS (M8 X 25)	41	
-	2	2	5-22278-1	SPRING, COMPRESSION	33	
-	2	2	1-2168083-4	SCR, SKT HD CAP, RoHS, M4 X 5	30	
-	1	1	2161336-2	PLATE, REAR STRIP GUIDE	29	
-	2	2	22281-9	SPRING, COMPRESSION	27	
-	1	1	356835-1	LEVER, DRAG RELEASE	26	
-	1	1	240792-1	DRAG, TERMINAL	25	
-	1	1	684042-5	GUIDE, STRIP, FRONT	24	
-	1	1	980371-4	SCR, SKT HD SHLDR 5.0 DIA X 6.0	23	
-	1	1	2168083-2	SCR, SKT HD CAP, RoHS, M4 X 8.0	21	
-	1	1	1-18028-2	WASHER, FLAT, REG M4	20	
-	1	1	2119533-1	STRIPPER, SIDE FEED	19	
-	1	1	463460-3	HOLD DOWN, TERMINAL	18	
-	1	1	469542-3	REAR FLOATING SHEAR	17	
-	2	2	1-2168083-1	SCR, SKT HD CAP, RoHS, M3 X 6	16	
-	1	1	2161335-2	SHEAR PLATE, REAR	15	
-	1	1	2119862-2	SHEAR HOLDER, REAR	14	
-	1	1	2280441-1	INSERT, SHEAR	13	
-	1	1	3-22280-3	SPRING, COMPRESSION	12	
-	1	1	356885-4	STOP, SHEAR	11	
-	1	1	462843-7	TERMINAL SUPPORT	9	
-	1	2	1	464291-5	ANVIL, SAND-BLASTED 12-10	8
-	1	1	1	803925-2	GUIDE, CARRIER SCRAP	7
-	1	1	1	690468-6	DEPRESSOR SHEAR, REAR	6
-	1	1	1	462431-5	WIRE FUNNEL	5
-	1	1	1	238011-1	BLOCK, CRIMPER SPACER	4
-	1	2	1	464290-3	CRIMPER, SEMI-FLAT 12-10	1

DIMENSIONS:		TOLERANCES UNLESS OTHERWISE SPECIFIED:		DWG		NAME	
mm	0 PLC ±	1 PLC ±	2 PLC ±	3 PLC ±	4 PLC ±	APVD	NAME
	ANGLES	FINISH	WEIGHT	SCALE	SHEET	OF	REV
MATERIAL				1:1	1	4	F1

ATLANTIC VERSION
Shown on sheets 1 of 4 & 2 of 4
(Pacific version shown on sheets 3 of 4 & 4 of 4)

LOC	DIST	REVISIONS			
P	LTN	DESCRIPTION	DATE	DMN	APVD
A	66	SEE SHEET 1	-	-	-

FEED TYPE PNEUMATIC

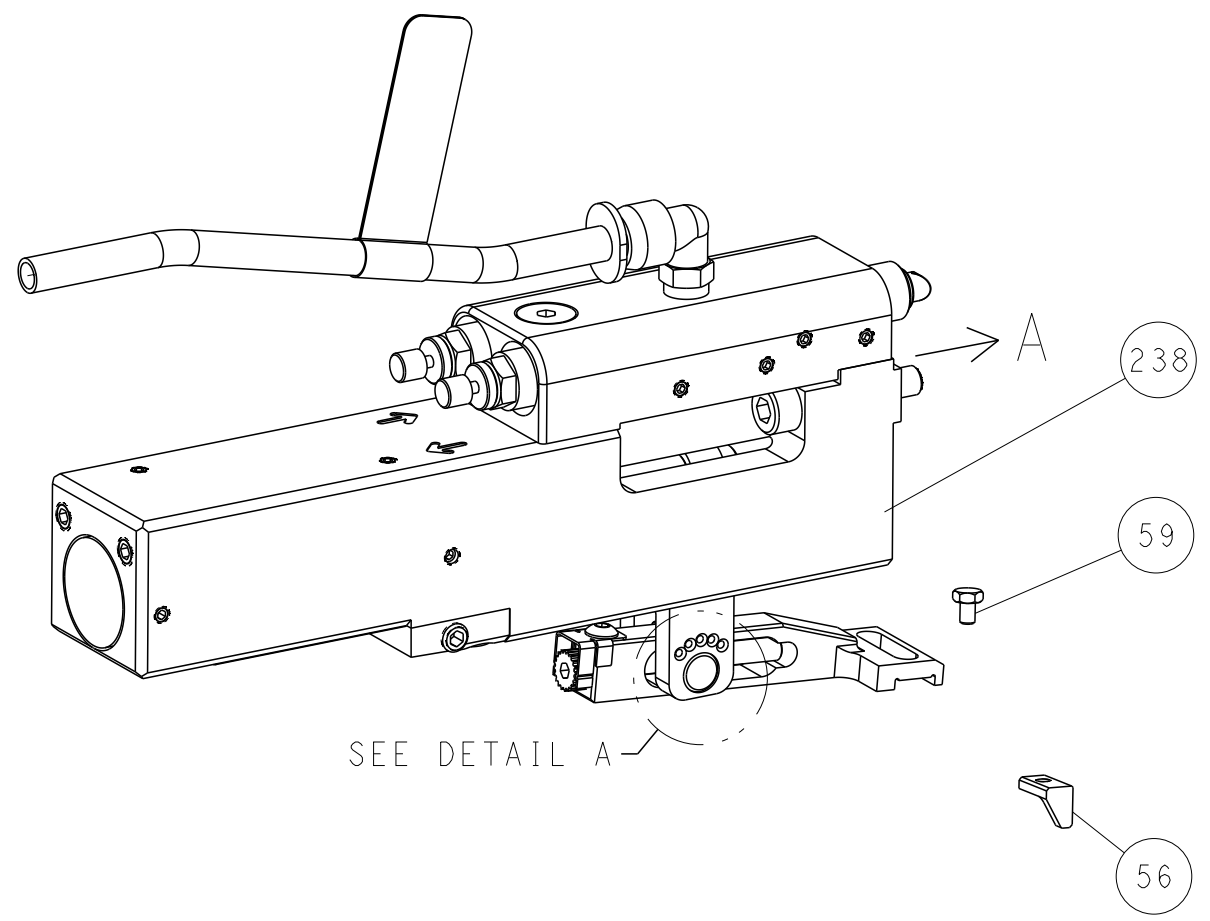

SEE DETAIL A

FEED SPRING SETTING POSITION (SHOWN FROM REAR SIDE)

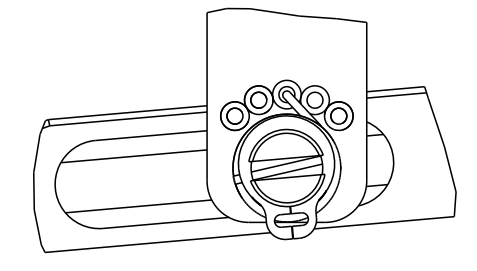

DETAIL A

CAM POSITION

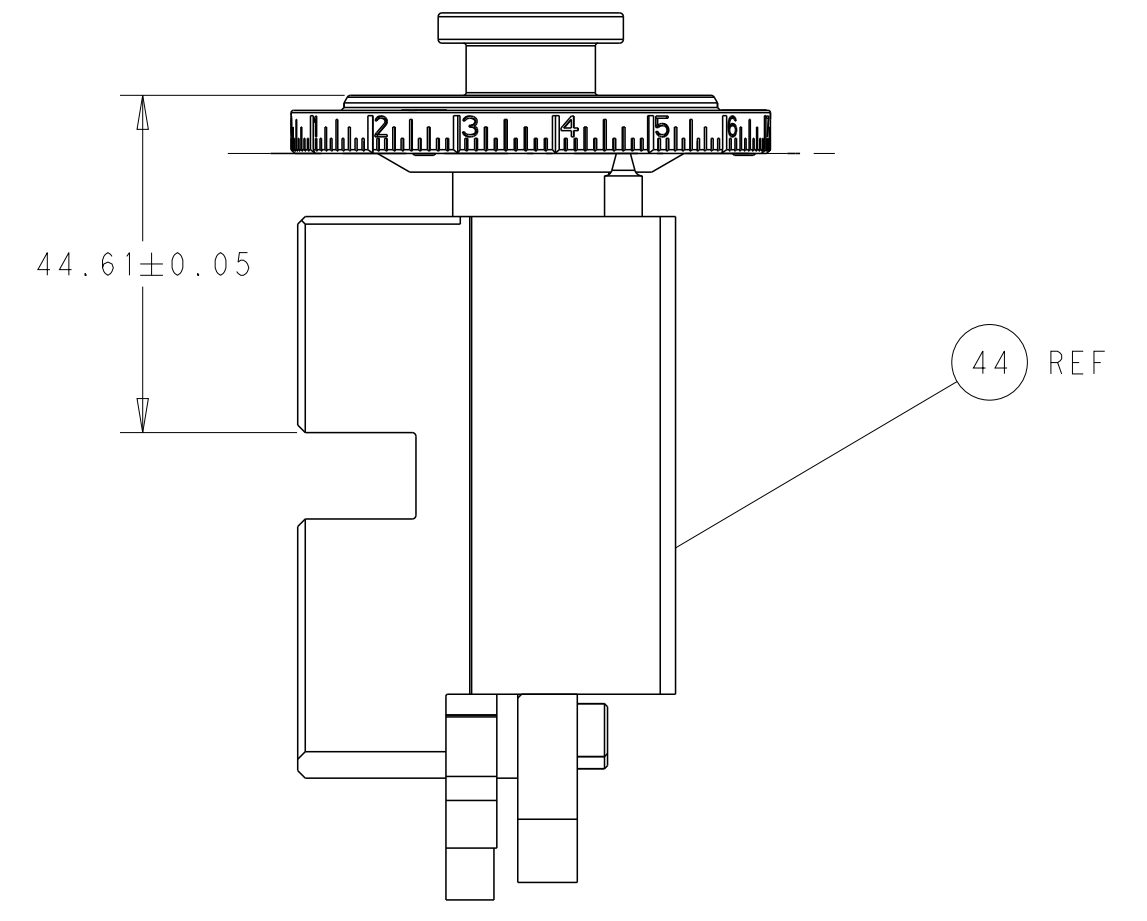
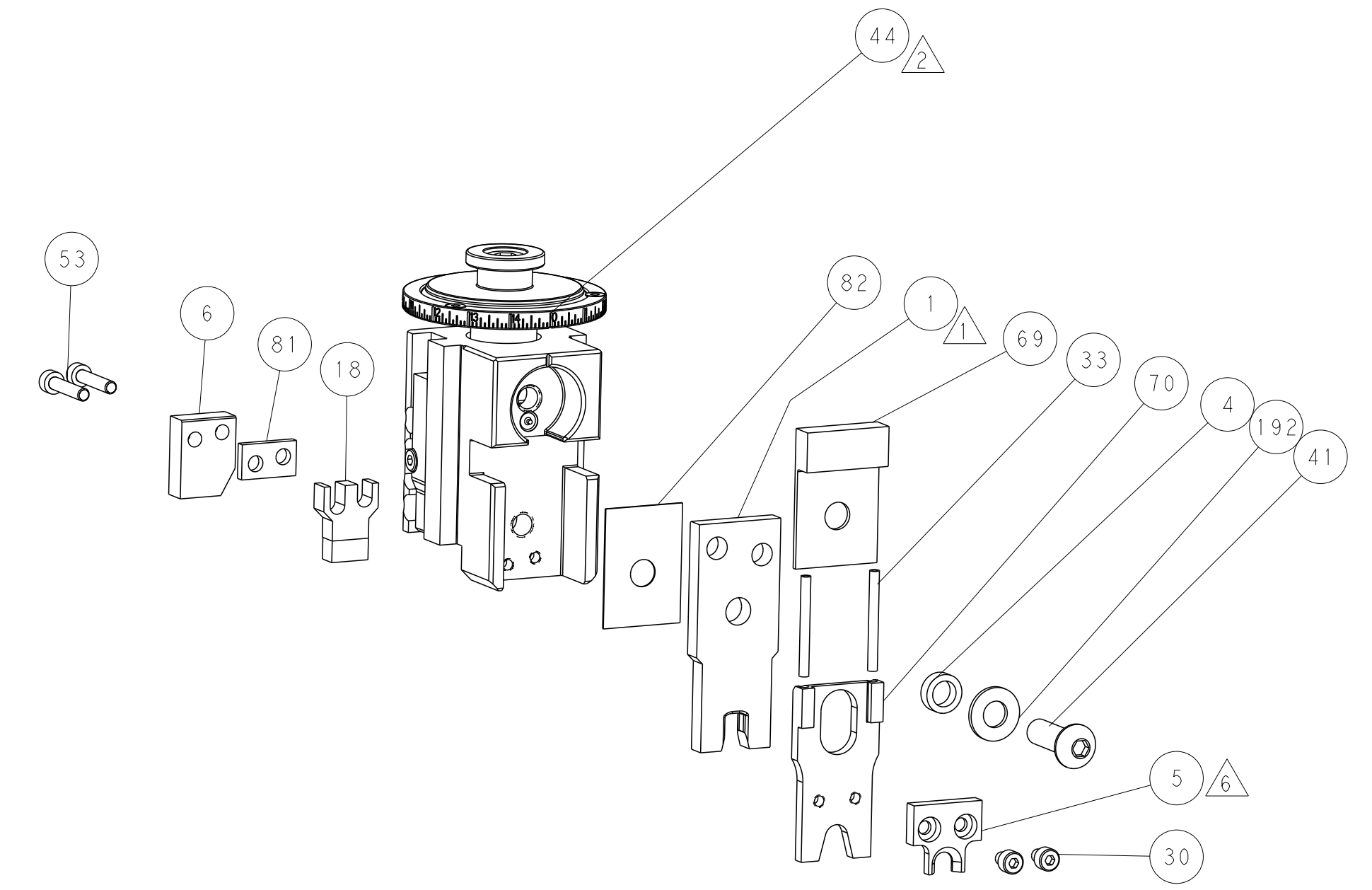
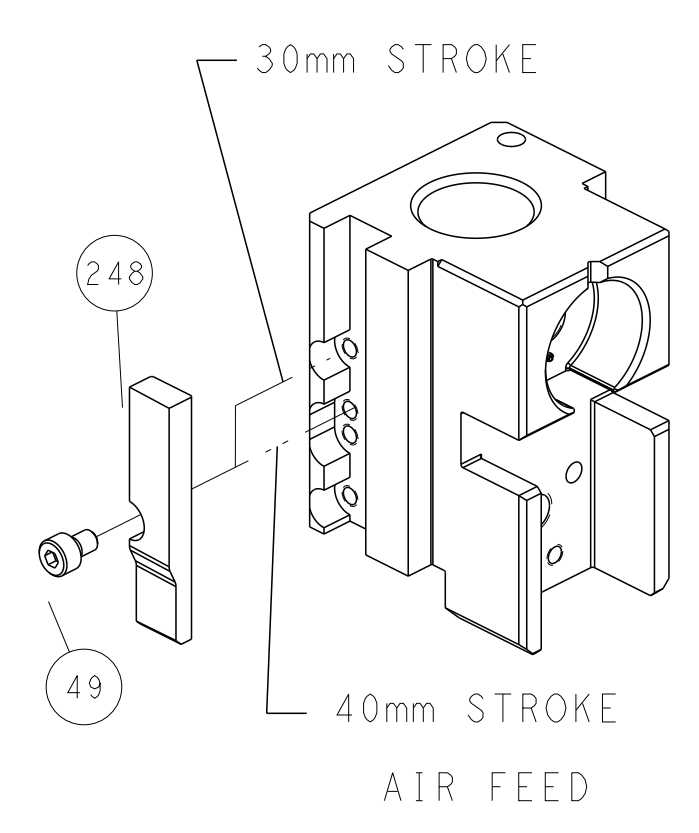

RAM SET-UP

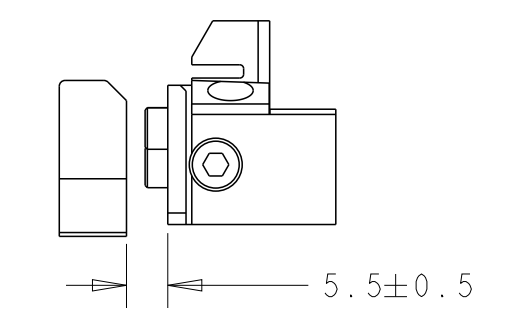

LOWER TOOLING SET-UP

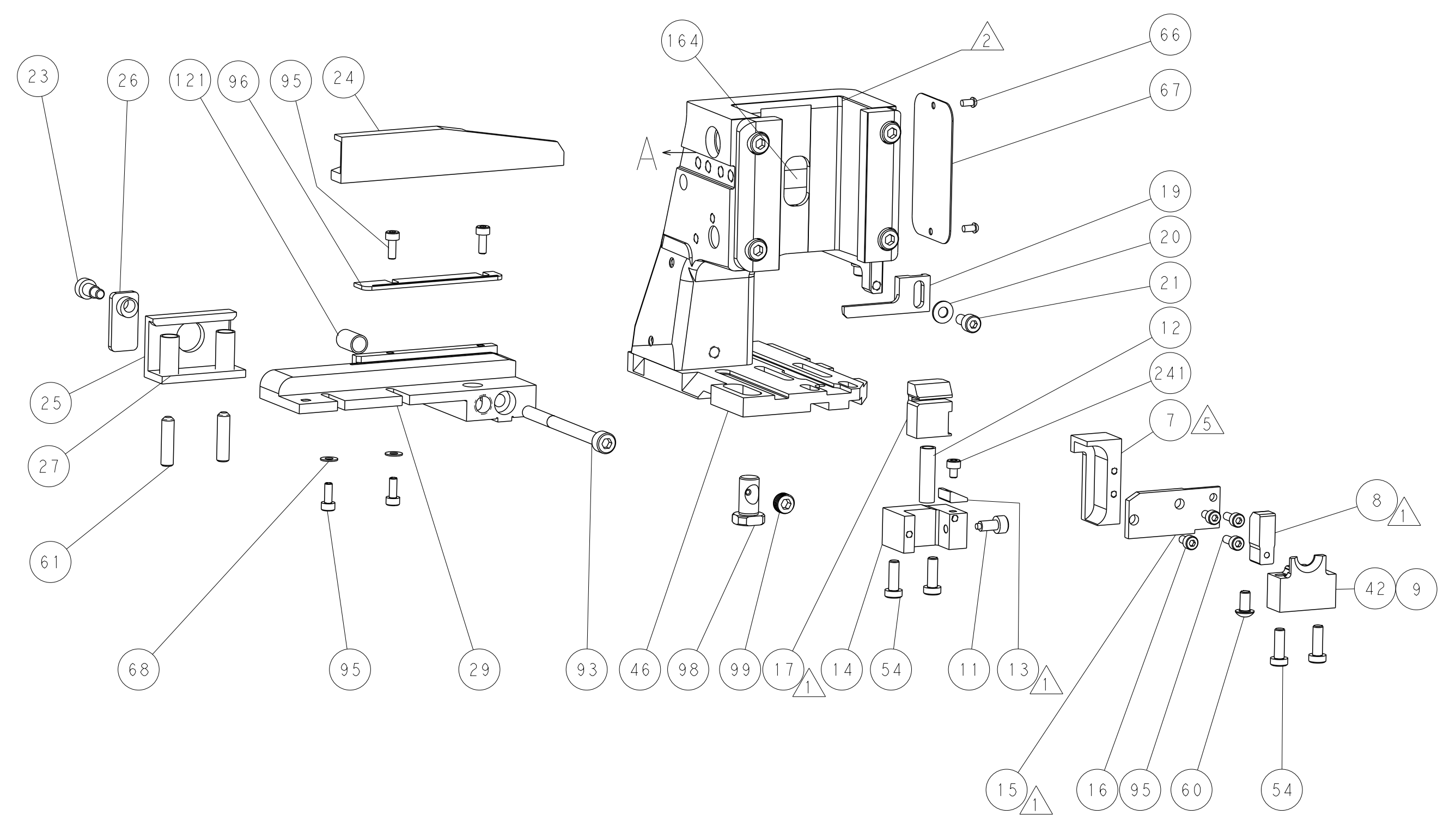

ATLANTIC VERSION
 Shown on sheets 1 of 4 & 2 of 4
 (Pacific version shown on sheets 3 of 4 & 4 of 4)

<small>THIS DRAWING IS UNPUBLISHED. RELEASED FOR PUBLICATION 2012. ALL RIGHTS RESERVED. © 2012 BY TYCO ELECTRONICS CORPORATION.</small>		DWN B. WEAVER 12JUN2012 CHK G. HOFFNER 12JUN2012 APVD T. ELBIN 12JUN2012	TE Connectivity Harrisburg, PA 17105-3608
DIMENSIONS: mm TOLERANCES UNLESS OTHERWISE SPECIFIED: 0 PLC ± 1 PLC ± 2 PLC ± 3 PLC ± 4 PLC ± ANGLES ± FINISH ±		NAME Ocean Side Feed Applicator PRODUCT SPEC APPLICATION SPEC SIZE CAGE CODE DRAWING NO. RESTRICTED TO A1 00779 C=2151029	WEIGHT SCALE 1:1 SHEET 2 OF 4 REV F1
MATERIAL:		Customer Accessible Production Drawing	

PART NUMBER	REVISION	DESCRIPTION	FEED TYPE
2-2151029-2	F	FINE CRIMP HEIGHT ADJUST	PNEUMATIC
7-2151029-7	A	CRIMP TOOLING KIT	-

APPLICATOR DATA		
CRIMP	SIZE	TYPE
WIRE	.278 [7.06 mm]	D
INSUL	-	-
APPLICATOR INSTRUCTIONS 408-35042		

TERMINAL DATA: TE TERMINAL		TE CRIMP SPECIFICATION	
TERMINAL NAME: FULLY INSULATED FASTON			
WIRE STRIP LENGTH		INSULATION DIAMETER RANGE	
.296-.328 IN [7.52-8.33 mm]		∅ .320 [8.13mm] MAX	
TERMINAL APPLICATION SPECIFICATION	114-2123		
TERMINALS APPLIED			
TE TERMINAL	TE TERMINAL	TE TERMINAL	TE TERMINAL
4-520447-2	9-520447-2	4-521097-2	

WIRE SIZE	CRIMP HEIGHT INCH [mm]	CRIMP HEIGHT REFERENCE SETTING	∅ SOLDER
10/3	0.100+/-0.002 [2.54+/-0.05]	5.1	.25 IN [6.35mm]
12 OR (4)18	0.095+/-0.002 [2.41+/-0.05]	6.3	.25 IN [6.35mm]

- RECOMMENDED SPARE PARTS
- REFER TO SUPPLIED INSTRUCTION SHEET FOR CLEANING, LUBRICATION AND STORAGE OF APPLICATOR.
- CRIMP HEIGHT REFERENCE SETTING WAS THE SETTING USED WHEN THE APPLICATOR WAS QUALIFIED AT THE FACTORY. ADJUSTMENT MAY BE NECESSARY WHEN RUNNING APPLICATOR IN THE FIELD.
- TO CONVERT THE APPLICATOR TO A NON-CARRIER CUTTING STYLE, REMOVE ITEM 13 AND ATTACH TO THE LOCATION ON THE BACK SIDE OF THE HOUSING. REFER TO INSTRUCTION SHEET FOR ADDITIONAL INFORMATION.
- ITEM 7 MUST BE REMOVED IF APPLICATOR IS USED ON BENCH MACHINE.
- ITEM 5 AND 9 ARE REQUIRED WHEN RUNNING ON A LEADMAKER. ITEM 42 REQUIRED WHEN RUNNING ON A BENCH MACHINE.
- FEED ADJUSTMENT MAY BE REQUIRED WHEN SWITCHING TERMINALS.
- TO CHECK CRIMP HEIGHT, CRIMP SOLDER (∅.25 IN [6.35mm] 60/40 SOLID CORE) AND MEASURE AT CENTER OF SLUG.
- IT MAY BE NECESSARY TO MODIFY THE T-TERMINATING/K-PRESS BASE PLATE BEFORE USE BY ADDING A 10-32 HOLE TO RELOCATE THE FORWARD STOP AS SHOWN.
- ITEMS 253 AND 255 MUST BE INSTALLED IN THE G-TERMINATING UNIT CHIP RELIEF HOLE BEFORE INSTALLING THE APPLICATOR.
- ITEM 257, REQUIRED IF APPLICATOR IS RUN ON T-TERMINATING UNIT/K-PRESS. GUARD, ITEM 256, REQUIRED IF APPLICATOR IS BEING USED ON G-TERMINATOR.
- TERMINAL PITCH NOT COMPATIBLE WITH MECHANICAL FEED.
- CONSULT PRODUCT ENGINEERING BEFORE USING 10AWG WIRE
- ITEMS NOT SHOWN.
- ITEM 261 REQUIRED WHEN APPLICATOR IS REMOVED FROM LEADMAKER AND PLACED IN AMP-O-LECTRIC* TERMINATING UNIT.

PACIFIC VERSION TERMINATOR INTERFACE ADAPTER

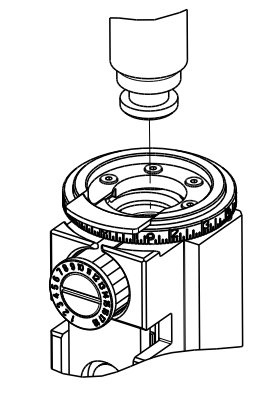

***WARNING**
 ON INSTALLATION, SET WIRE DISC TO CRIMP HEIGHT REFERENCE SETTING FOR LARGEST WIRE SIZE. CRIMP HEIGHT REFERENCE SETTINGS GREATER THAN THE VALUE SHOWN MAY CAUSE DAMAGE TO THE CRIMP TOOLING, REFER TO THE INSTRUCTION SHEET FOR PROPER SETUP AND ADJUSTMENTS.

PACIFIC VERSION
 Shown on sheets 3 of 4 & 4 of 4
 (Atlantic version shown on sheets 1 of 4 & 2 of 4)

LOC	DIST	REVISIONS					
A	66	P	LTN	DESCRIPTION	DATE	OWN	APVD
		-		SEE SHEET 1			

	-	1	1-18023-1	SCR, SHC, M4x10			262
	-	1	803931-1	BRACKET, HOLD DOWN			261
	-	REF	462992-5	GUARD ASSY			257
	-	REF	679532-1	INSERT, GUARD			256
	-	1	189728-1	BRACKET, SPACER			255
	-	1	568681-1	SPACER, BASE PLATE			253
	-	1	7-18023-7	SCR, SKT HD CAP M3 X 4.0			241
	-	1	2844940-2	AIR FEED MODULE			238
	-	1	1-18028-0	WASHER, FLAT, REG M8			192
	-	REF	994970-2	COUNTER, MAGNETIC			164
	-	1	2119641-2	FEED CAM, AIR FEED			151
	-	1	2079383-8	SCR, BHSC, RoHS (M4 X 16)			144
	-	4	2168400-5	SHCS, LOW HEAD, RoHS, M4 X 20			143
	-	1	2-1803583-0	APPLICATOR BASIC ASSEMBLY, SF			141
	-	1	1803516-1	RAM ASSEMBLY, SF PACIFIC			140
	-	1	1-22281-8	SPRING, COMPRESSION			121
	-	1	2844908-1	SCREW, LOCKING			99
	-	1	2844907-1	POST, LOCKING			98
	-	1	1-690438-0	FRONT STRIP GUIDE			96
	-	6	2168083-1	SCR, SKT HD CAP, RoHS, M3 X 8.0			95
	-	1	2168083-6	SCR, SKT HD CAP, RoHS, M5 X 65			93
	-	1	455888-4	SPACER, CRIMPER			82
	-	1	240641-6	SPACER			81
	-	1	1803607-3	DOCUMENTATION PACKAGE			71
	-	1	2161332-2	DEPRESSOR, WIRE FUNNEL			70
	-	1	2161331-1	SPACER, WIRE FUNNEL DEPRESSOR			69
	-	2	1-18028-4	WASHER, FLAT, REG M3			68
	-	1	2119740-1	TAG, IDENTIFICATION			67
	-	2	2168078-1	SCREW, DRIVE, RH, RoHS, 2 x .188			66
	-	2	2-18032-5	SCR, SET, FLT PNT, M5 X 20.0			61
	-	1	5-18022-5	SCR, HEX HD CAP, M4 X 6.0			59
	-	1	462427-2	FINGER, FEED			56
	-	2	2168083-9	SCR, SKT HD CAP, RoHS, M4 X 20			53
	-	1	18023-9	SCR, SKT HD CAP M4 X 6.0			49
	-	1	462433-8	SUPPORT, INSULATION			42
	-	1	1803602-1	SCR, BHSC, RoHS (M8 X 25)			41
	-	2	5-22278-1	SPRING, COMPRESSION			33
	-	2	1-2168083-4	SCR, SKT HD CAP, RoHS, M4 X 5			30
	-	1	2161336-2	PLATE, REAR STRIP GUIDE			29
	-	2	22281-9	SPRING, COMPRESSION			27
	-	1	356835-1	LEVER, DRAG RELEASE			26
	-	1	240792-1	DRAG, TERMINAL			25
	-	1	684042-5	GUIDE, STRIP, FRONT			24
	-	1	980371-4	SCR, SKT HD SHLDR 5.0 DIA X 6.0			23
	-	1	2168083-2	SCR, SKT HD CAP, RoHS, M4 X 8.0			21
	-	1	1-18028-2	WASHER, FLAT, REG M4			20
	-	1	2119533-1	STRIPPER, SIDE FEED			19
	-	1	463460-3	HOLD DOWN, TERMINAL			18
	-	1	469542-3	REAR FLOATING SHEAR			17
	-	2	1-2168083-1	SCR, SKT HD CAP, RoHS, M3 X 6			16
	-	1	2161335-2	SHEAR PLATE, REAR			15
	-	1	2119862-2	SHEAR HOLDER, REAR			14
	-	1	2280441-1	INSERT, SHEAR			13
	-	1	3-22280-3	SPRING, COMPRESSION			12
	-	1	356885-4	STOP, SHEAR			11
	-	1	462843-7	TERMINAL SUPPORT			9
	1	1	464291-5	ANVIL, SAND-BLASTED 12-10			8
	-	1	803925-2	GUIDE, CARRIER SCRAP			7
	-	1	690468-6	DEPRESSOR SHEAR, REAR			6
	-	1	462431-5	WIRE FUNNEL			5
	-	1	238011-1	BLOCK, CRIMPER SPACER			4
	1	1	464290-3	CRIMPER, SEMI-FLAT 12-10			1

DIMENSIONS:		TOLERANCES UNLESS OTHERWISE SPECIFIED:		MATERIAL:		FINISH:		WEIGHT:		SCALE:	
mm	0 PLC ±	1 PLC ±	2 PLC ±	3 PLC ±	4 PLC ±	ANGLES	FINISH				

LOC	DIST	REVISIONS			
P	LTN	DESCRIPTION	DATE	DWN	APVD
-	-	SEE SHEET 1	-	-	-

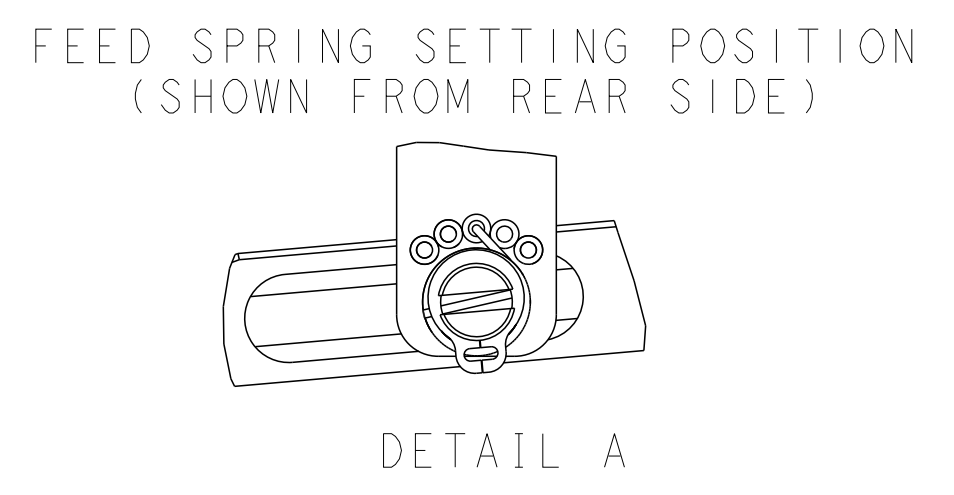
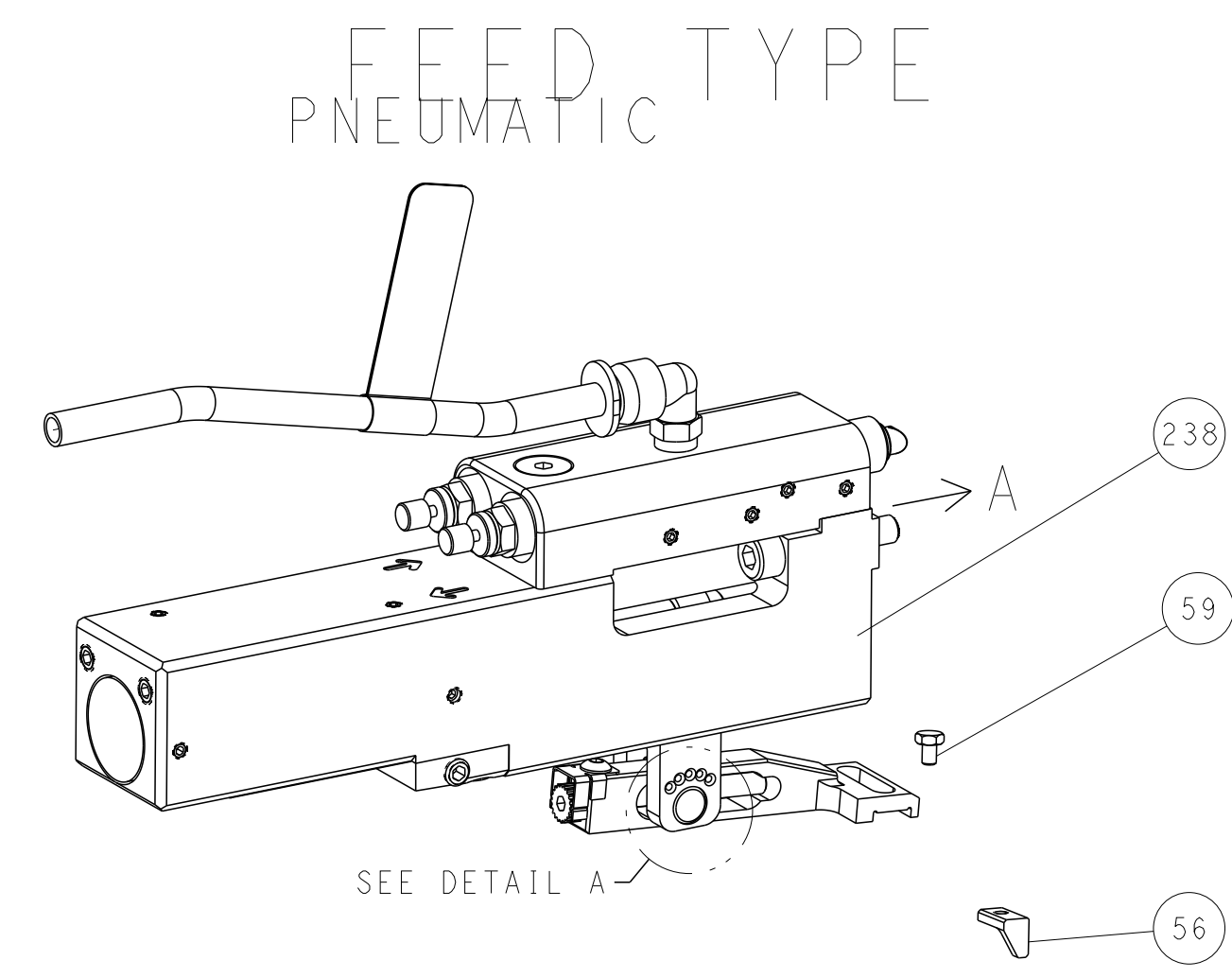

CAM POSITION

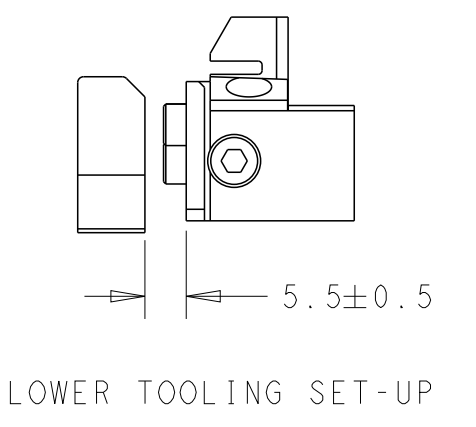
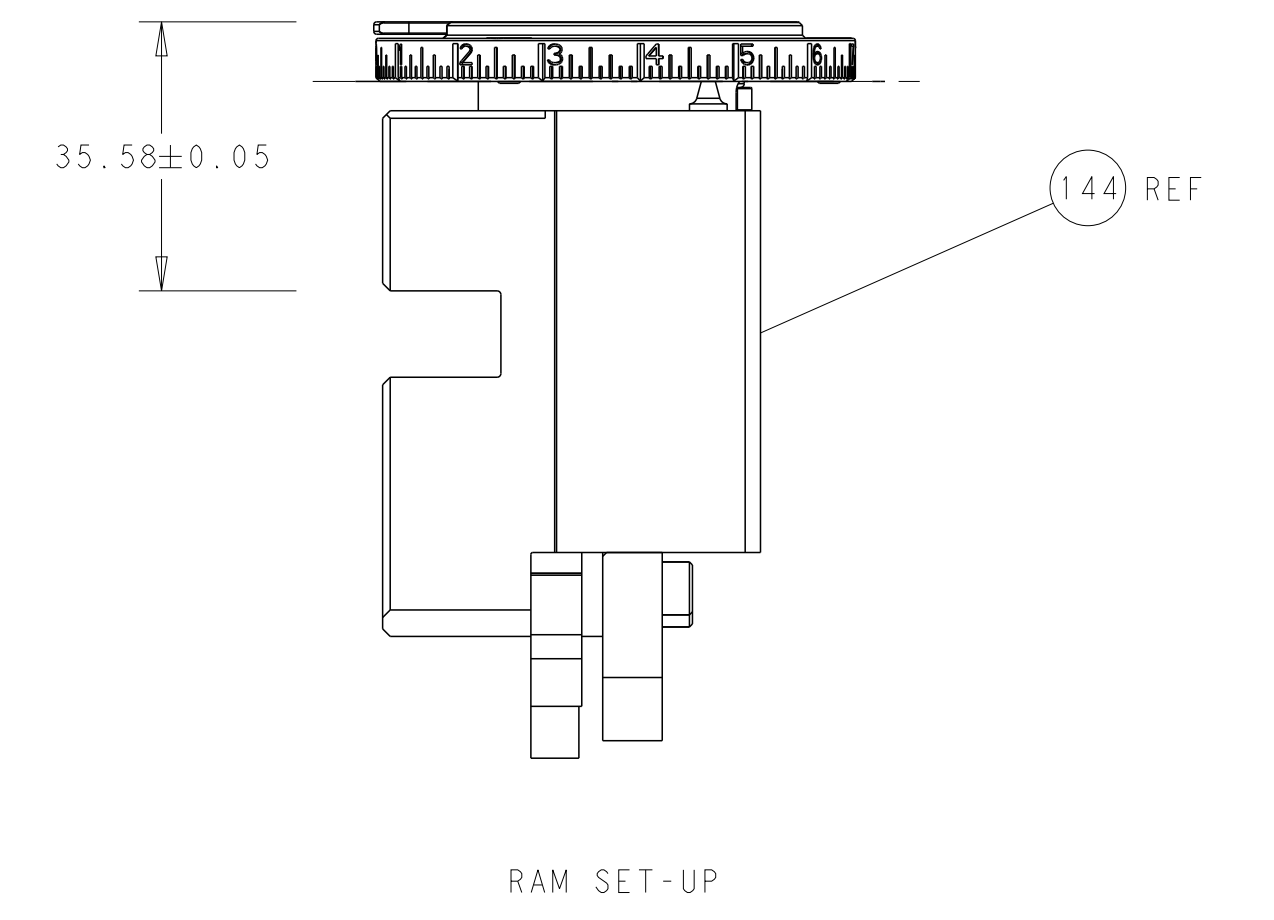
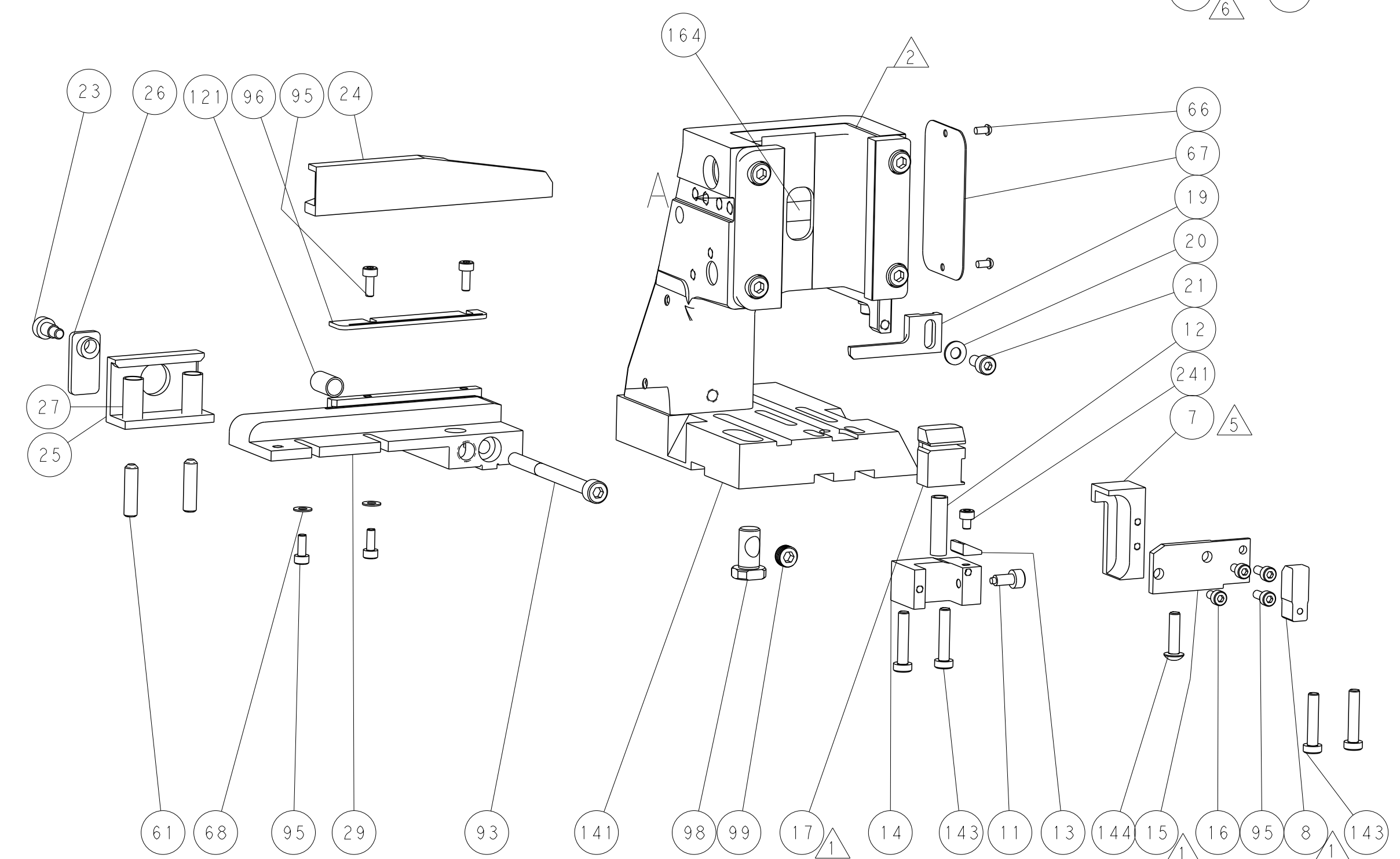
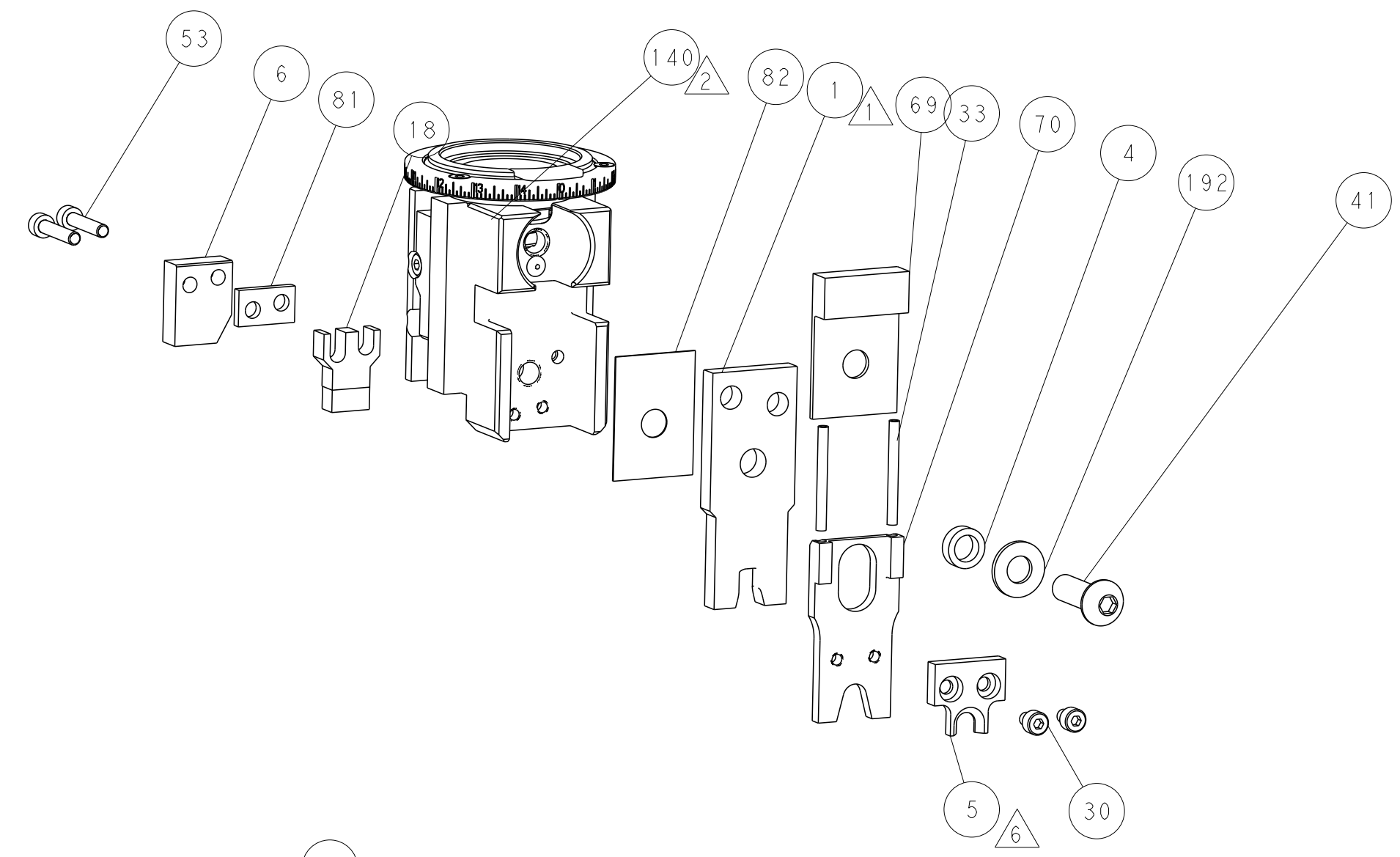
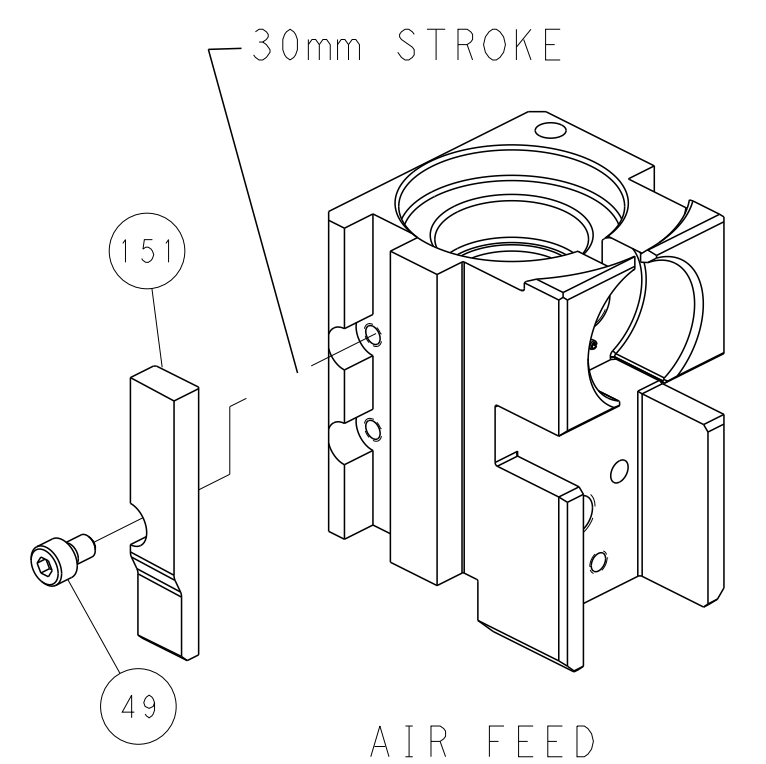

PACIFIC VERSION
 Shown on sheets 3 of 4 & 4 of 4
 (Atlantic version shown on sheets 1 of 4 & 2 of 4)

<small>THIS DRAWING IS UNPUBLISHED. RELEASED FOR PUBLICATION 2012. ALL RIGHTS RESERVED. THIS DRAWING IS UNPUBLISHED. RELEASED FOR PUBLICATION 2012. ALL RIGHTS RESERVED.</small>		DWN: B. WEAVER 12JUN2012 CHK: G. HOFENER 12JUN2012 APVD: T. ELBIN 12JUN2012	NAME: Ocean Side Feed Applicator SIZE: A1 CAGE CODE: 00779 DRAWING NO: C=2151029	RESTRICTED TO: - SCALE: 1:1 SHEET: 4 OF 4 REV: F1
DIMENSIONS: mm TOLERANCES UNLESS OTHERWISE SPECIFIED: 0 PLC ± 1 PLC ± 2 PLC ± 3 PLC ± 4 PLC ± ANGLES ± FINISH	DIMENSIONS: mm TOLERANCES UNLESS OTHERWISE SPECIFIED: 0 PLC ± 1 PLC ± 2 PLC ± 3 PLC ± 4 PLC ± ANGLES ± FINISH	WEIGHT: - MATERIAL: -	PRODUCT SPEC: - APPLICATION SPEC: -	CUSTOMER ACCESSIBLE PRODUCTION DRAWING