

VOLTAGE REGULATOR FOR CAR RADIO APPLICATIONS

- OPERATION SUPPLY VOLTAGE 9.5 TO 28V
- PEAK SUPPLY OVERVOLTAGE PULSE UP TO 52V (VS. GND)
- FIXED OUTPUT VOLTAGE OF $8.6 \pm 0.2V$ AND OUTPUT CURRENT UP TO 150mA
- VERY LOW DROP OUTPUT STAGE WITH LOW OUTPUT VOLTAGE DIAGNOSTIC
- OUTPUT SHORT CIRCUIT AND THERMAL OVERLOAD PROTECTION
- VERY LOW STANDBY CURRENT (DEVICE DISABLED)
- TWO INTERNAL OUTPUT VOLTAGE SWITCHES WITH LOW DROPOUT FOR AM/FM SWITCHING
- DRIVER CIRCUIT FOR EXTERNAL HIGH SIDE SWITCH WITH DROP MONITORING
- ENABLE INPUT TO SWITCH ON THE DEVICE
- ADDITIONAL 10V VERY LOW DROP REGULATOR TO SUPPLY THE VARICAP

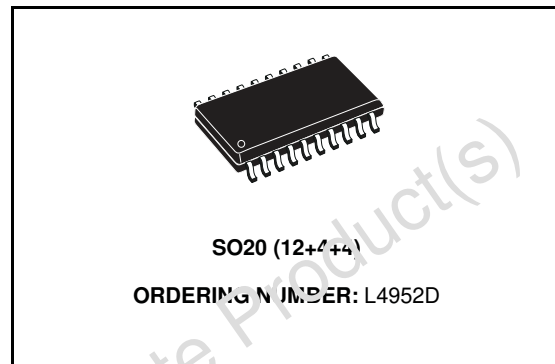

DESCRIPTION

The L4952 is a monolithic voltage regulator in an advanced BCD60II process with high efficient p-channel transistor. This device is optimized for Car Radio applications to obtain optimum performance and supply system integration with high flexibility and minimum peripheral components.

BLOCK DIAGRAM

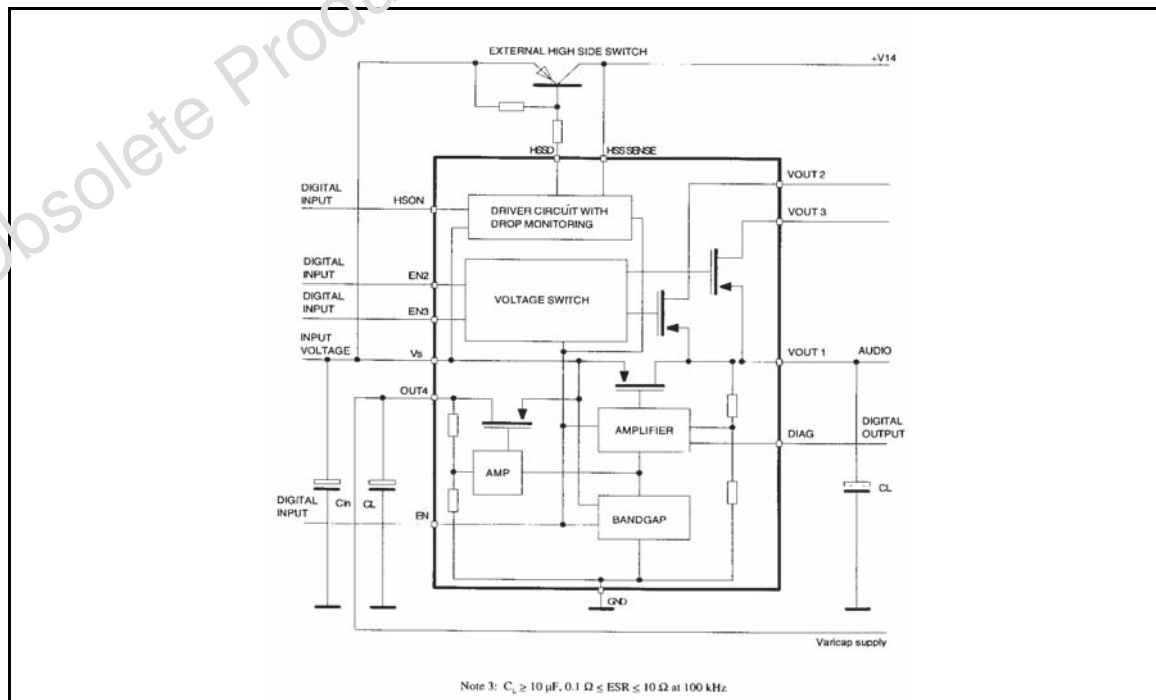

ABSOLUTE MAXIMUM RATINGS

Symbol	Parameter	Value	Unit
V_s	DC supply voltage	-2.2 .. +28	V
V_{st}	Transient operating supply voltage for $t = 400\text{ms}$	-2.2 .. +52	V
$V_{o1,2,3,4}$	Output voltages	-0.3 .. +12	V
V_{EN}	Input voltage of EN	-0.3 .. +18	V
V_{IND}	Input voltage for EN2, EN3, HSON	-18 .. +18	V
$V_s - V_{IND}$	Max Voltage Difference between V_s and logic inputs EN2, EN3, HSON	52	V
V_{DIAG}	Diagnostic output	-0.3 .. +20	V
I_{o1}	Output current out1, out4	short circuit protected	mA
$I_{o2,3}$	Output current out2,3 (Note 1)	internally limited	mA
I_{oDIAG}	Output current Diagnostic	10	mA
I_{HSSD}	Driver current for external pnp High side switch	internally limited	mA
T_J	Operating junction temperature	-40 .. +150	°C
P_o	Power dissipation with on board heat sink 2cm^2		W
V_{ESD}	ESD voltage capability (MIL 883 C)	± 2000	V

Note: Current limiter of OUT1 will also protect OUT2 and OUT3 as long as OUT1 is not reverse supplied. Output capacitors up to $100\mu\text{F}$ between OUT and GND will not harm this protection.

PIN CONNECTION

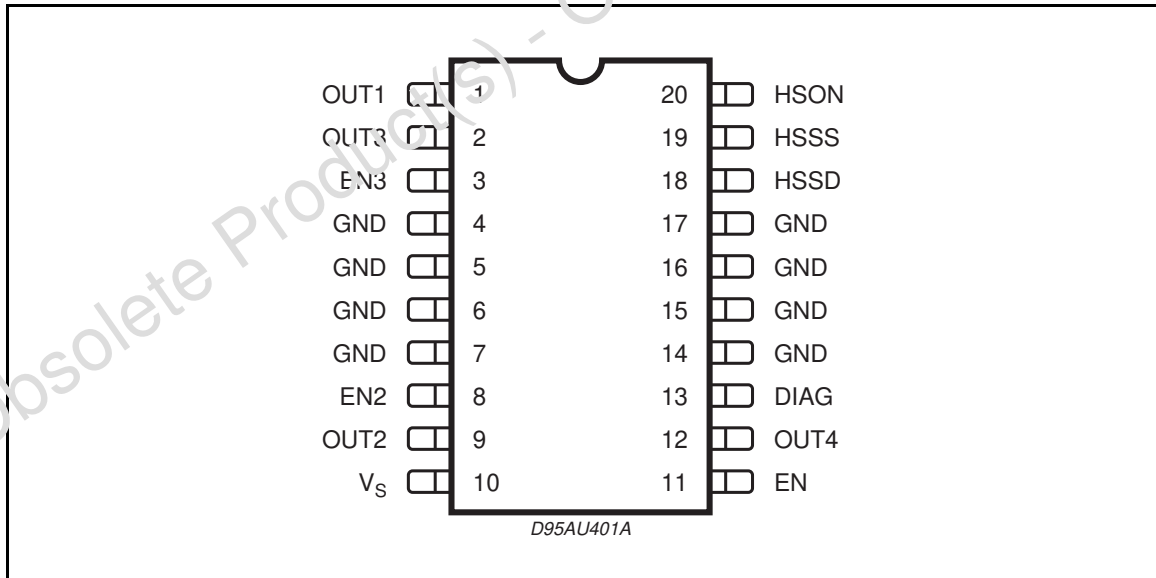

THERMAL DATA

Symbol	Parameter	Value	Unit
$R_{th j-amb}$	Thermal Resistance Junction to Ambient with on board heatsink 2cm^2	60	°C/W
T_{JSD}	Thermal shutdown junction temperature	>150	°C

ELECTRICAL CHARACTERISTICS ($V_S = 14V$; $T_J = 25^\circ C$ unless otherwise specified)

Symbol	Parameter	Test Condition	Min.	Typ.	Max.	Unit
I_S	V_S Quiescent current	no Load		1.6	5	mA
I_{SSB}	V_S standby current	EN = 0V		0	20	μA
V_{INLEN}	Low Voltage EN		-0.3		0.5	V
V_{INHEN}	High Voltage EN	$V_S = 18V$	3.5		18	V
$V_{INL EN2,3}$	EN2, EN3, Low Voltage		-18		1.05	V
$V_{INH EN2,3}$	EN2, EN3, High Voltage	$V_S = 18V$	1.45		18	V
$V_{INL HSON}$	HSON Low Voltage		-18		1.0	V
$V_{INH HSON}$	HSON High Voltage	$V_S = 18V$	2.0		18	V
I_{INH}	Current EN2, EN3, HSON	$V_{in} = 5V$		30	70	μA
I_{INL}	Current EN2, EN3, HSON	$V_{in} = 0V$	-10		10	μA
$I_{IN ON/OFF}$	Current High EN	$V_{in} = 5V$	-10	100	200	μA
Voltage Regulator (OUT 1)						
V_{O1}	Output voltage	no load	8.4	8.6	8.8	V
V_{DP1}	Dropout voltage	$V_S = 8.4V, V_{DP1} = V_S - V_{out1}$				
		$I_{O1} = 0.15A, I_{O2,3} = 0mA$		0.16	0.6	V
		$I_{O1} = 0.1A, I_{O2,3} = 0mA$		0.11	0.4	V
		$I_{O1} = 0.05A, I_{O2,3} = 0mA$		0.06	0.2	V
SVRR	Supply Voltage ripple rejection	$f = 100Hz, C = 10\mu F, ESR = 5\Omega$	60	70		dB
V_{oLo}	Load regulation	$10mA < I_o < 150mA$		30	60	mV
I_{oLim1}	Current limits	$V_{OUT} = 8V$	150	300	800	mA
Voltage Regulator (OUT 4)						
V_{O4}	Output voltage	no load	9.5	10.0	10.5	V
V_{DP4}	Dropout voltage	$I = 3mA, V_S = 8.6V$		0.14	0.3	V
		$I = 1.5mA, V_S = 8.6V$		0.075	0.15	V
SVRR	Supply Voltage ripple rejection	$f = 100Hz, C = 10\mu F, ESR = 5\Omega$	30	60		dB
V_{O4Lo}	Load regulation	$0.5mA < I < 3mA$		100		mV
I_{O4Lim}	Current limits	$V_{OUT} = 8V$	8	60		mA
Diagnostic Output						
V_{LDIAG}	Output Diagnostic Low voltage	R_{DIAG} to 5 V = 10K Ω			0.4	V
ΔV_{out}	Output voltage drop before diagnostic activation	$V_S > 6V, I_{O1} = 100mA, I_{O2} = I_{O3} = 0mA$		30	200	mV
Voltage Switches Vout2/3						
V_{DP2}	Dropout V_{out2}	$I_{O2} = 50mA, EN_2 = H$		0.25	0.5	V
		$I_{O2} = 25mA, EN_2 = H$		0.125	0.25	V
V_{DP3}	Dropout V_{out3}	$I_{O3} = 75mA, EN_3 = L$		0.25	0.5	V
		$I_{O3} = 40mA, EN_3 = L$		0.14	0.28	V
High Side Switch Driver						
V_{DPHS}	Low Drop Voltage	$I_{out} = 50mA, HSON = H$		0.26	0.8	V
V_{DPHS}	Drop detection threshold	$V_{Dth} = V_S - V_{14}, HSON = H$	0.7	1	1.3	V

FUNCTIONAL DESCRIPTION

The L4952 is a monolithic voltage regulator with an output voltage of typically 8.6V and a maximum output current of 150mA. It's a device for audio applications in car radios.

The device contains a precision Bandgap reference, an output amplifier with overcurrent protection, two voltage switches, a driver for an external

pnp switch, a discharge circuitry for theft detection and an overtemperature protection.

For automatic PCB assembly the package is SO12+4+4. To use the maximal current of 150mA a small copper area of 2cm² as heat sink on board ($R_{th} = 60K/W$) is necessary.

The device has a very low quiescent current in standby mode. If the digital Input EN is Low the device is switched off (stand by mode) and if EN

Figure 1: Application Circuit Diagram

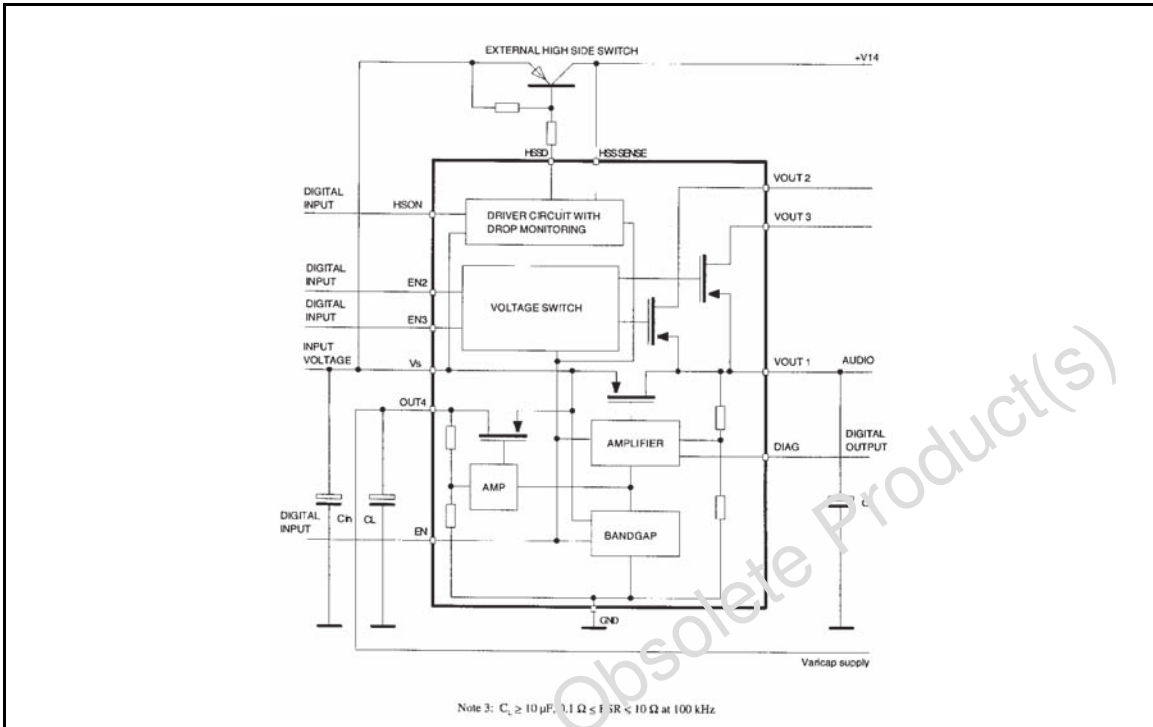

Figure 2.

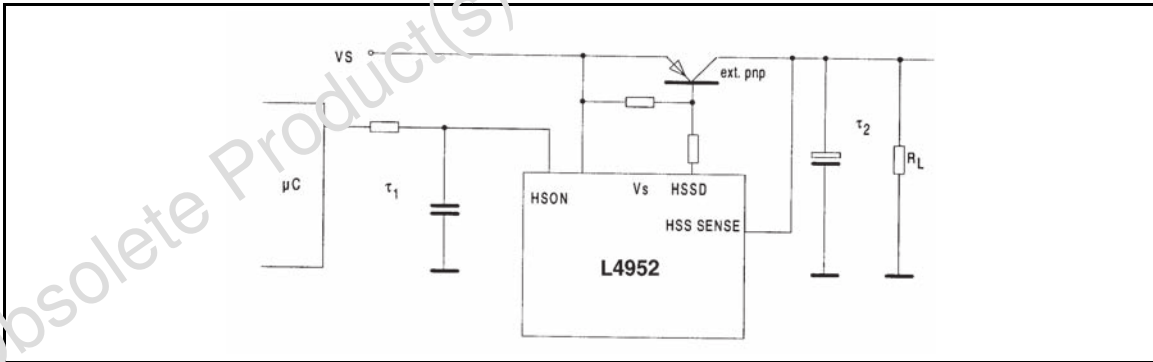
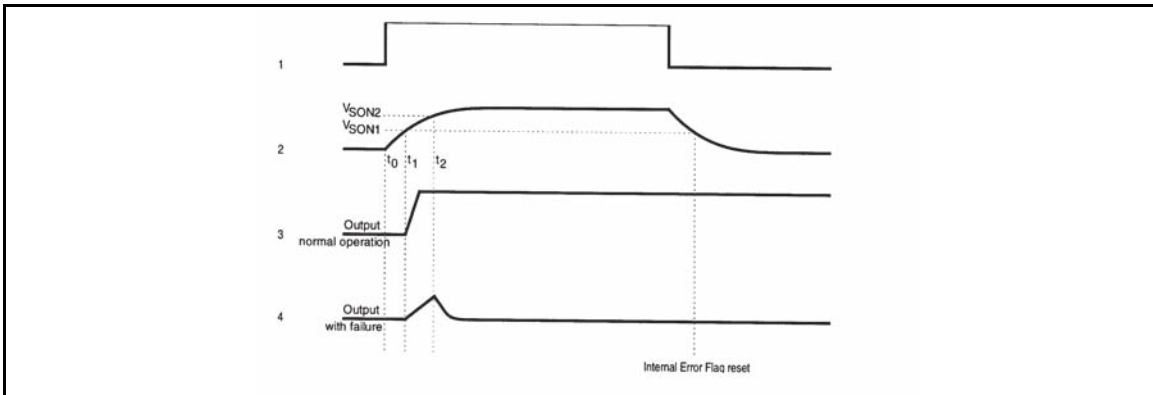

Figure 3.



is High the device is switched on. The diagnostic circuitry detect the low drop voltage.

In this case the DIAG output is going low and can mute the power output stage to avoid noise on the loudspeaker. The two internal switches can switch the stabilized output voltage with P-MOS Transistors to one of the outputs 2 and 3 with low drop. This is useful to switch the AM and FM circuitry on or off.

To control it there are two digital inputs EN₂ and EN₃ one for each switch. EN₂ is High active and EN₃ is Low active. It's possible to drive the AM/FM switch with one digital line (EN₂ and EN₃ together).

The driver for the external High side switch can switch on and off the external pnp transistor. The drop detection circuitry avoid the damage of the external power pnp transistor.

To supply the varicaps and the PLL-opamp of the car radio a second very low drop 10 V regulator is available. This regulator in dropout has a typical resistance of 50Ω.

Typical Characteristics (Note 4)

Figure 3: Stand by consumption versus temperature

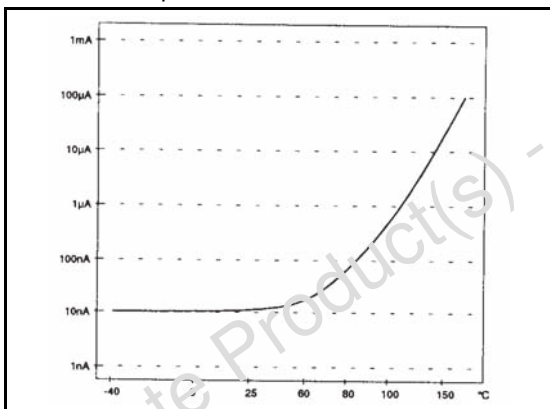

Supply voltage rejection (C = 10µF, ESR = 4.7Ω, Load at OUT4 = 10kΩ)

Figure 5: Supply rejection versus Frequency.

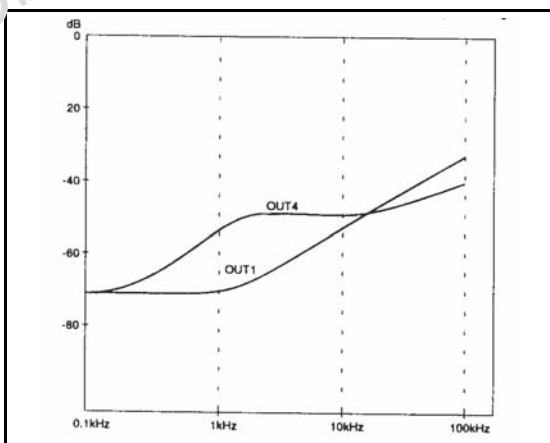

Function of the external High side switch driver

Fig 2 shows the principle circuitry of the external High side switch. Fig. 3 shows the switch on/off phase of the external High side switch. At the time t₀ the microcontroller switches on (curve 1 = output signal of the microcontroller).

The signal on the HSON pin of the L4952 is shown on curve 2. At t₁ the external Power pnp is switched on. At t₂ (V_{HSON} = V_{SON2}) the internal comparator compares the drop of the external pnp. In case of normal operation the drop is smaller than V_{Dth} and no failure will be detected (curve 3).

In case of failure (that mean a higher drop than V_{Dth}) the external power pnp will be switched off (curve 4). If an error is detected it will be stored in the internal error flip-flop. The external pnp can only be switched on again after having turned HSON off (V_{HSON} < V_{SON1}) again.

Figure 4: Logic input currents versus input voltage

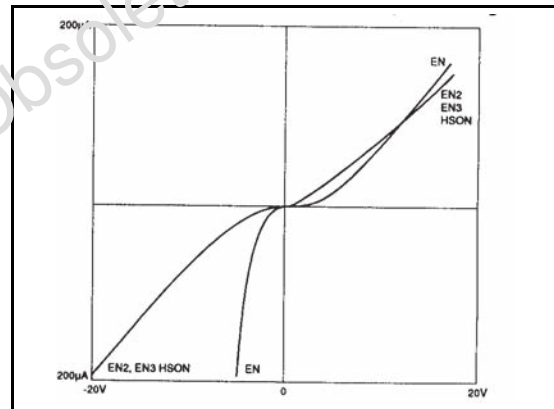

OUT2 propagation delay (Load = 100Ω)

Figure 6: OUT2 propagation delay (Load = 100Ω)

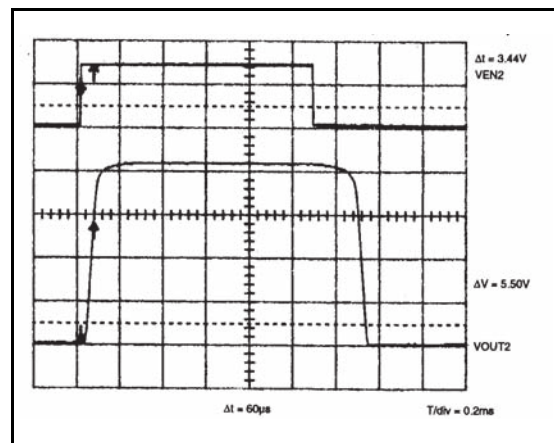

Figure 7: OUT3 propagation delay (Load = 100Ω)

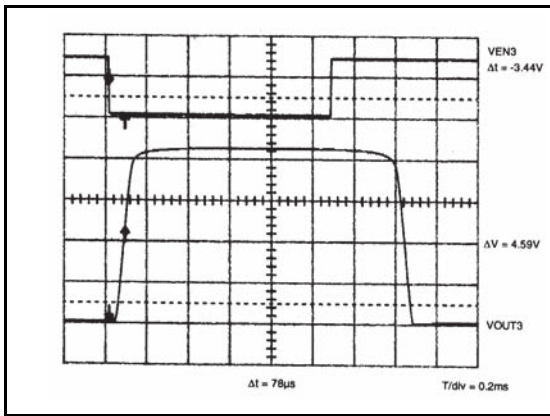

Figure 8: OUT1 supply transient rejection (C = 10µF, ESR = 4.7Ω, Load at OUT1 = 100Ω, Load = 10kΩ)

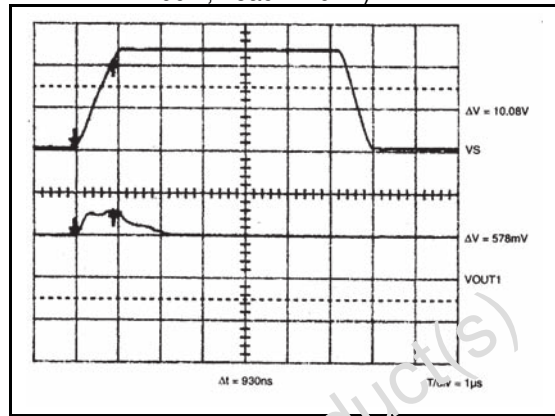

Figure 9: (C = 10µF, ESR = 4.7Ω Load current 0mA and 117mA)

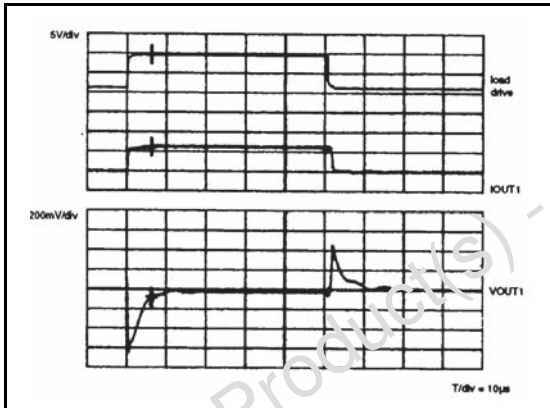

Figure 10: OUT1 voltage versus temperature

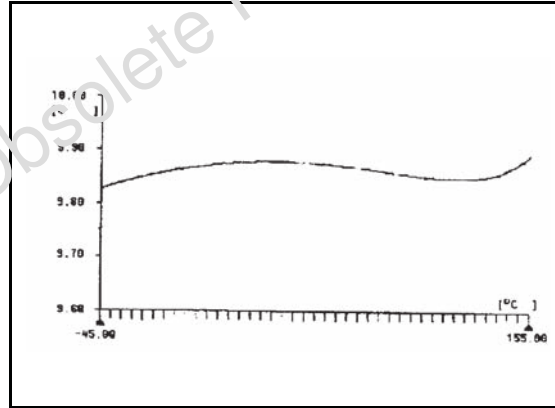

Figure 11: OUT4 supply transient response (C = 10µF, ESR = 4.7Ω, Load = 3mA)

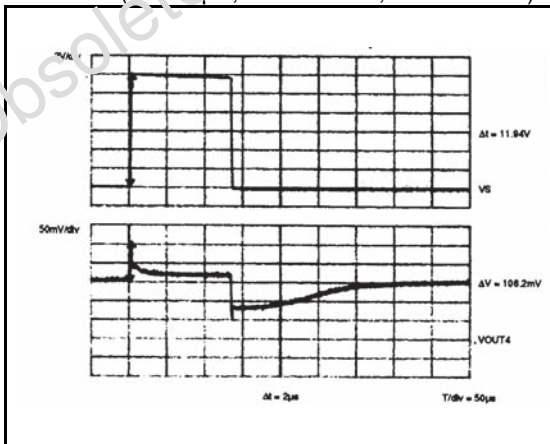
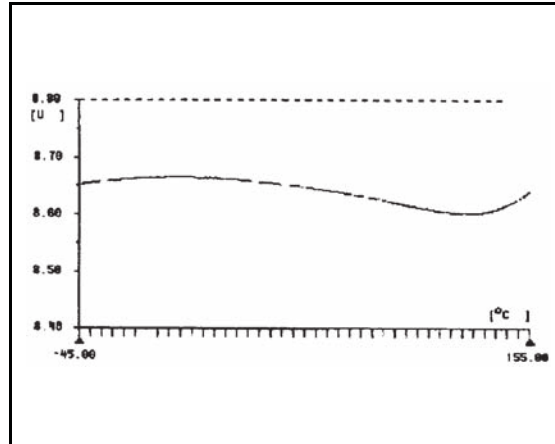

Figure 12: OUT4 voltage versus temperature



Note 4

Typical characteristics shown by the Figures 3 to 12 are typical parameters. Depending on produc-

tion spread certain deviations may occur. For limits see pages 2 to 4.

DIM.	mm			inch		
	MIN.	TYP.	MAX.	MIN.	TYP.	MAX.
A	2.35		2.65	0.093		0.104
A1	0.1		0.3	0.004		0.012
B	0.33		0.51	0.013		0.020
C	0.23		0.32	0.009		0.013
D	12.6		13	0.496		0.512
E	7.4		7.6	0.291		0.299
e		1.27			0.050	
H	10		10.65	0.394		0.419
h	0.25		0.75	0.010		0.030
L	0.4		1.27	0.016		0.050
K	0° (min.)8° (max.)					

OUTLINE AND MECHANICAL DATA

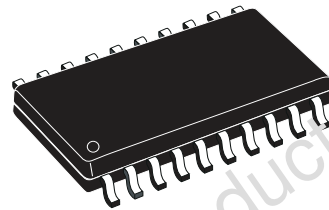

SO20

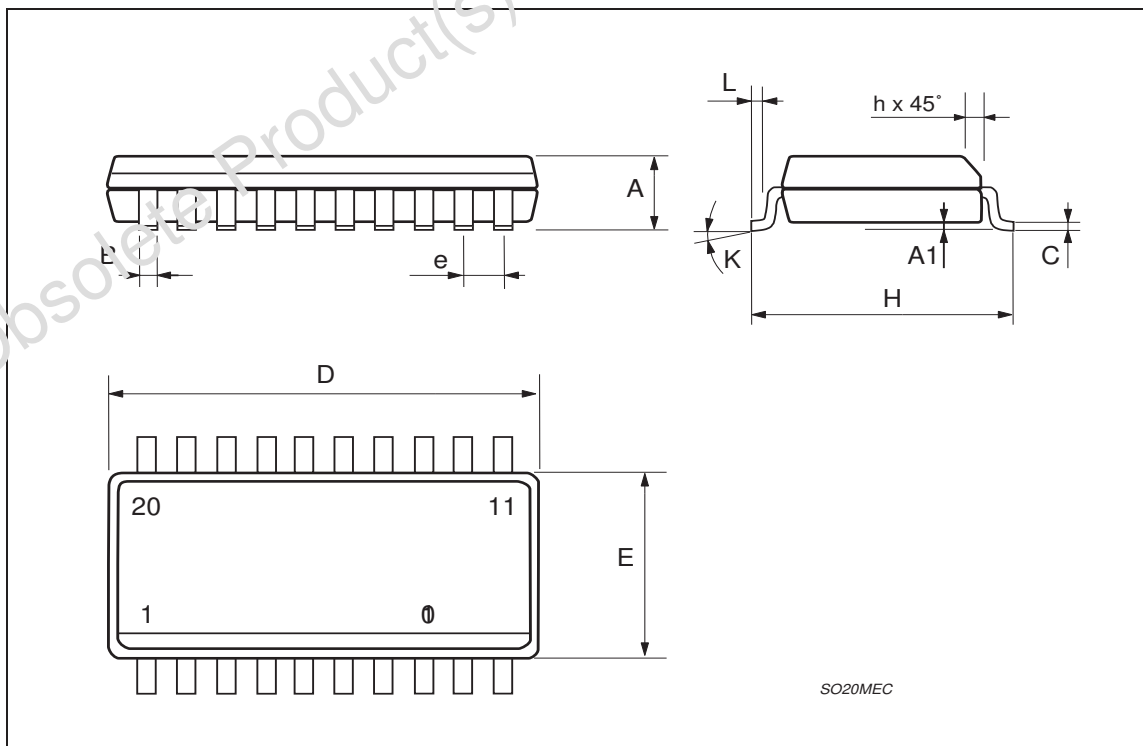

Obsolete Product(s) - Obsolete Product(s)

Information furnished is believed to be accurate and reliable. However, STMicroelectronics assumes no responsibility for the consequences of use of such information nor for any infringement of patents or other rights of third parties which may result from its use. No license is granted by implication or otherwise under any patent or patent rights of STMicroelectronics. Specification mentioned in this publication are subject to change without notice. This publication supersedes and replaces all information previously supplied. STMicroelectronics products are not authorized for use as critical components in life support devices or systems without express written approval of STMicroelectronics.

The ST logo is a registered trademark of STMicroelectronics

© 2000 STMicroelectronics – Printed in Italy – All Rights Reserved

STMicroelectronics GROUP OF COMPANIES

Australia - Brazil - China - Finland - France - Germany - Hong Kong - India - Italy - Japan - Malaysia - Malta - Morocco -
Singapore - Spain - Sweden - Switzerland - United Kingdom - U.S.A.

<http://www.st.com>