

# 6-Channel High-Speed Logic-Level Translators

## General Description

The MAX13030E–MAX13035E 6-channel, bidirectional level translators provide the level shifting necessary for 100Mbps data transfer in multivoltage systems. The MAX13030E–MAX13035E are ideally suited for memory-card level translation, as well as generic level translation in systems with six channels. Externally applied voltages,  $V_{CC}$  and  $V_L$ , set the logic levels on either side of the device. Logic signals present on the  $V_L$  side of the device appear as a higher voltage logic signal on the  $V_{CC}$  side of the device and vice versa. The MAX13035E features a CLK\_RET output that returns the same clock signal applied to the CLK\_VL input.

The MAX13030E–MAX13035E operate at full speed with external drivers that source as little as 4mA output current. Each I/O channel is pulled up to  $V_{CC}$  or  $V_L$  by an internal  $30\mu A$  current source, allowing the MAX13030E–MAX13035E to be driven by either push-pull or open-drain drivers.

The MAX13030E–MAX13034E feature an enable (EN) input that places the device into a low-power shutdown mode when driven low. The MAX13030E–MAX13035E features an automatic shutdown mode that disables the part when  $V_{CC}$  is less than  $V_L$ . The state of I/O  $V_{CC\_}$  and I/O  $V_{L\_}$  during shutdown is chosen by selecting the appropriate part version (see *Ordering Information/Selector Guide*).

The MAX13030E–MAX13035E accept  $V_{CC}$  voltages from +2.2V to +3.6V and  $V_L$  voltages from +1.62V to +3.2V, making them ideal for data transfer between low-voltage ASIC/PLDs and higher voltage systems. The MAX13030E–MAX13035E are available in 16-bump UCSP (2mm x 2mm) and 16-pin TQFN (4mm x 4mm) packages, and operate over the extended -40°C to +85°C temperature range.

## Applications

- SD Card Level Translation
- MiniSD Card Level Translation
- MMC Level Translation
- Transflash Level Translation
- Memory Stick Card Level Translation

## Features

- ◆ Compatible with 4mA Input Drivers or Larger
- ◆ 100Mbps Guaranteed Data Rate
- ◆ Six Bidirectional Channels
- ◆ Clock Return Output (MAX13035E)
- ◆ Enable Input (MAX13030E–MAX13034E)
- ◆  $\pm 15kV$  ESD Protection on I/O  $V_{CC}$  Lines
- ◆  $+1.62V \leq V_L \leq +3.2V$  and  $+2.2V \leq V_{CC} \leq +3.6V$  Supply Voltage Range
- ◆ Lead-Free, 16-Bump UCSP (2mm x 2mm) and 16-pin TQFN (4mm x 4mm) Packages

## Typical Operating Circuits

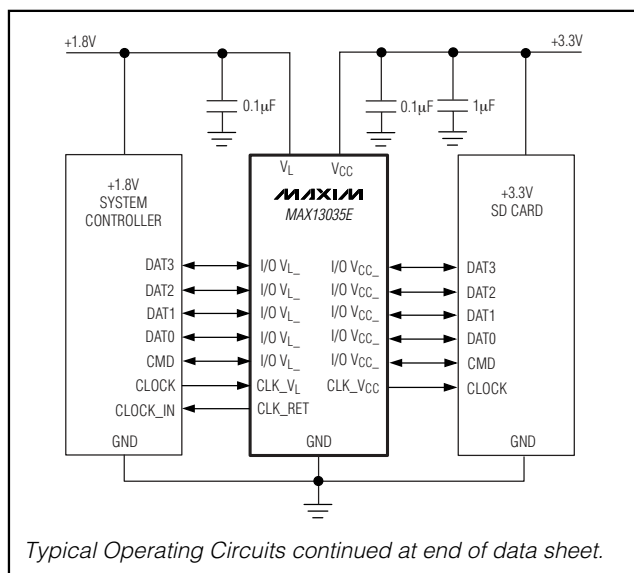

Functional Diagram and Pin Configurations appear at end of data sheet.

## Ordering Information/Selector Guide

PART	PIN-PACKAGE	I/O $V_{L\_}$ STATE DURING SHUTDOWN	I/O $V_{CC\_}$ STATE DURING SHUTDOWN	PKG CODE
MAX13030EEBE+	16 UCSP	High impedance	High impedance	B16-1
MAX13030EETE+	16 TQFN-EP**	High impedance	High impedance	T1644-4

**Note:** All devices are specified over the -40°C to +85°C operating temperature range.

+Denotes a lead-free package.

\*\*EP = Exposed paddle.

Ordering Information/Selector guide continued at end of data sheet.

## 6-Channel High-Speed Logic-Level Translators

### ABSOLUTE MAXIMUM RATINGS

(All voltages referenced to GND.)

V <sub>CC</sub> , V <sub>L</sub> .....	-0.3V to +4V
I/O V <sub>CC_</sub> , CLK_V <sub>CC</sub> .....	-0.3V to (V <sub>CC</sub> + 0.3V)
I/O V <sub>L</sub> , CLK_V <sub>L</sub> , CLK_RET .....	-0.3V to (V <sub>L</sub> + 0.3V)
EN .....	-0.3V to +4V
Short-Circuit Duration I/O V <sub>L</sub> , I/O V <sub>CC_</sub> , CLK_V <sub>CC</sub> , CLK_V <sub>L</sub> , CLK_RET to GND .....	Continuous
Continuous Power Dissipation (T <sub>A</sub> = +70°C)	
16-Bump UCSP (derate 8.2mW/°C) .....	660mW
16-Pin TQFN (derate 25.0mW/°C) .....	2000mW

Operating Temperature Range .....	-40°C to +85°C
Storage Temperature Range .....	-65°C to +150°C
Junction Temperature .....	+150°C
Bump Temperature (soldering) .....	+235°C
Lead Temperature (soldering, 10s) .....	+300°C

Stresses beyond those listed under "Absolute Maximum Ratings" may cause permanent damage to the device. These are stress ratings only, and functional operation of the device at these or any other conditions beyond those indicated in the operational sections of the specifications is not implied. Exposure to absolute maximum rating conditions for extended periods may affect device reliability.

### ELECTRICAL CHARACTERISTICS

(V<sub>CC</sub> = +2.2V to +3.6V, V<sub>L</sub> = +1.62V to +3.2V, EN = V<sub>L</sub>, T<sub>A</sub> = -40°C to +85°C, unless otherwise noted. Typical values are at V<sub>CC</sub> = +3.3V, V<sub>L</sub> = +1.8V and T<sub>A</sub> = +25°C.) (Notes 1, 2)

PARAMETER	SYMBOL	CONDITIONS	MIN	TYP	MAX	UNITS
<b>POWER SUPPLIES</b>						
V <sub>L</sub> Supply Range	V <sub>L</sub>	(Note 2)	1.62		3.20	V
V <sub>CC</sub> Supply Range	V <sub>CC</sub>		2.2		3.6	V
Supply Current from V <sub>CC</sub>	I <sub>QVCC</sub>	I/O V <sub>CC_</sub> = V <sub>CC</sub> , I/O V <sub>L</sub> = V <sub>L</sub>		16	25	μA
Supply Current from V <sub>L</sub>	I <sub>QVL</sub>	I/O V <sub>CC_</sub> = V <sub>CC</sub> , I/O V <sub>L</sub> = V <sub>L</sub>		6	10	μA
V <sub>CC</sub> Shutdown Supply Current	I <sub>SHDN-VCC</sub>	T <sub>A</sub> = +25°C, EN = GND or V <sub>L</sub> > V <sub>CC</sub> + 0.7V, MAX13030E-MAX13034E		2	4	μA
		T <sub>A</sub> = +25°C, V <sub>L</sub> > V <sub>CC</sub> + 0.7V, MAX13035E,		2	4	
V <sub>L</sub> Shutdown Supply Current	I <sub>SHDN-VL</sub>	T <sub>A</sub> = +25°C, EN = GND or V <sub>L</sub> > V <sub>CC</sub> + 0.7V, MAX13030E-MAX13034E		0.1	4	μA
		T <sub>A</sub> = +25°C, V <sub>L</sub> > V <sub>CC</sub> + 0.7V, MAX13035E		0.1	4	
I/O V <sub>CC_</sub> , I/O V <sub>L</sub> , CLK_V <sub>CC</sub> Tri-State Leakage Current	I <sub>LEAK</sub>	T <sub>A</sub> = +25°C, EN = GND or V <sub>L</sub> > V <sub>CC</sub> + 0.7V		0.1	2	μA
EN Input Leakage Current	I <sub>LEAK_EN</sub>	T <sub>A</sub> = +25°C, MAX13030E-MAX13034E			1	μA
V <sub>L</sub> - V <sub>CC</sub> Shutdown Threshold High	V <sub>TH_H</sub>	V <sub>CC</sub> rising	-0.2	0.05V <sub>L</sub>	0.7	V
V <sub>L</sub> - V <sub>CC</sub> Shutdown Threshold Low	V <sub>TH_L</sub>	V <sub>CC</sub> falling	-0.2	0.1V <sub>L</sub>	0.7	V
I/O V <sub>CC_</sub> Pulldown Resistance During Shutdown	R <sub>VCC_PD_SD</sub>	EN = GND, MAX13032E/MAX13034E	10	16.5	23	kΩ
I/O V <sub>CC_</sub> Pullup Resistance During Shutdown	R <sub>VCC_PU_SD</sub>	EN = GND, MAX13031E	10	16.5	23	kΩ
I/O V <sub>L</sub> Pulldown Resistance During Shutdown	R <sub>VL_PD_SD</sub>	EN = GND, MAX13033E/MAX13034E	10	16.5	23	kΩ

# 6-Channel High-Speed Logic-Level Translators

## ELECTRICAL CHARACTERISTICS (continued)

( $V_{CC} = +2.2V$  to  $+3.6V$ ,  $V_L = +1.62V$  to  $+3.2V$ ,  $EN = V_L$ ,  $T_A = -40^{\circ}C$  to  $+85^{\circ}C$ , unless otherwise noted. Typical values are at  $V_{CC} = +3.3V$ ,  $V_L = 1.8V$  and  $T_A = +25^{\circ}C$ .) (Notes 1, 2)

PARAMETER	SYMBOL	CONDITIONS	MIN	TYP	MAX	UNITS
I/O $V_L$ , CLK_ $V_L$ , CLK_RET Pullup Resistance During Shutdown	$R_{VL\_PU\_SD}$	( $V_L > V_{CC} + 0.7V$ ), MAX13035E	45	75	105	$k\Omega$
I/O $V_L$ , CLK_ $V_L$ , CLK_RET Pullup Current	$R_{VL\_PU}$	$EN = V_{CC}$ or $V_L$ , I/O $V_L = GND$	20			$\mu A$
I/O $V_{CC}$ , CLK_ $V_{CC}$ Pullup Current	$R_{VCC\_PU}$	$EN = V_{CC}$ or $V_L$ , I/O $V_{CC} = GND$	20			$\mu A$
I/O $V_L$ to I/O $V_{CC}$ DC Resistance	$R_{IOVL\_IOVCC}$	(Note 3)		3		$k\Omega$
<b>ESD PROTECTION (Note 3)</b>						
I/O $V_{CC}$ , CLK_ $V_{CC}$		Human Body Model, $C_{VCC} = 1.0\mu F$		$\pm 15$		$kV$
		IEC 61000-4-2 Air-Gap Discharge, $C_{VCC} = 1.0\mu F$		$\pm 12$		
		IEC 61000-4-2 Contact Discharge, $C_{VCC} = 1.0\mu F$		$\pm 8$		
<b>LOGIC-LEVEL THRESHOLDS</b>						
I/O $V_L$ , CLK_ $V_L$ Input-Voltage High Threshold	$V_{IHL}$	(Note 4)			$V_L - 0.2$	V
I/O $V_L$ , CLK_ $V_L$ Input-Voltage Low Threshold	$V_{ILL}$	(Note 4)	0.15			V
I/O $V_{CC}$ , CLK_ $V_{CC}$ Input-Voltage High Threshold	$V_{IHC}$	(Note 4)			$V_{CC} - 0.4$	V
I/O $V_{CC}$ , CLK_ $V_{CC}$ Input-Voltage Low Threshold	$V_{ILC}$	(Note 4)	0.2			V
EN Input-Voltage High Threshold	$V_{IH}$	MAX13030E-MAX13034E			$V_L - 0.4$	V
EN Input-Voltage Low	$V_{IL}$	MAX13030E-MAX13034E	0.4			V
I/O $V_L$ , CLK_ $V_L$ , CLK_RET Output-Voltage High	$V_{OHL}$	I/O $V_L$ , CLK_ $V_L$ , CLK_RET source current = $20\mu A$ , I/O $V_{CC} \geq V_{CC} - 0.4V$	$2/3 V_L$			V
I/O $V_L$ , CLK_ $V_L$ , CLK_RET Output-Voltage Low	$V_{OLL}$	I/O $V_L$ , CLK_ $V_L$ , CLK_RET sink current = $20\mu A$ , I/O $V_{CC} \leq 0.2V$		$1/3 V_L$		V
I/O $V_{CC}$ , CLK_ $V_{CC}$ Output-Voltage High	$V_{OHC}$	I/O $V_{CC}$ , CLK_ $V_{CC}$ source current = $20\mu A$ , I/O $V_L \geq V_L - 0.2V$	$2/3 V_{CC}$			V

MAX13030E-MAX13035E

## 6-Channel High-Speed Logic-Level Translators

### ELECTRICAL CHARACTERISTICS (continued)

( $V_{CC} = +2.2V$  to  $+3.6V$ ,  $V_L = +1.62V$  to  $+3.2V$ ,  $EN = V_L$ ,  $T_A = -40^\circ C$  to  $+85^\circ C$ , unless otherwise noted. Typical values are at  $V_{CC} = +3.3V$ ,  $V_L = 1.8V$  and  $T_A = +25^\circ C$ .) (Notes 1, 2)

PARAMETER	SYMBOL	CONDITIONS	MIN	TYP	MAX	UNITS
I/O $V_{CC\_}$ , CLK_ $V_{CC}$ Output-Voltage Low	$V_{OLC}$	I/O $V_{CC\_}$ , CLK_ $V_{CC}$ sink current = $20\mu A$ , I/O $V_{L\_} \leq 0.15V$			1/3 $V_{CC}$	V
<b>RISE/FALL TIME ACCELERATOR STAGE (Note 3)</b>						
Accelerator Pulse Duration		On falling edge		3		ns
		On rising edge		3		
$V_L$ -Output-Accelerator Source Impedance		$V_L = 1.62V$		11		$\Omega$
		$V_L = 3.2V$		6		
$V_{CC}$ -Output-Accelerator Source Impedance		$V_{CC} = 2.2V$		9		$\Omega$
		$V_{CC} = 3.6V$		8		
$V_L$ -Output-Accelerator Sink Impedance		$V_L = 1.62V$		9		$\Omega$
		$V_L = 3.2V$		8		
$V_{CC}$ -Output-Accelerator Sink Impedance		$V_{CC} = 2.2V$		10		$\Omega$
		$V_{CC} = 3.6V$		9		

### TIMING CHARACTERISTICS

( $V_{CC} = +2.2V$  to  $+3.6V$ ,  $V_L = +1.62V$  to  $+3.2V$ ,  $C_{I/OVL} \leq 15pF$ ,  $C_{I/OVCC} \leq 15pF$ ,  $R_{SOURCE} = 150\Omega$ ,  $EN = V_L$ , I/O  $V_{L\_}$  to I/O  $V_{CC\_}$  rise/fall time =  $3ns$ ,  $T_A = -40^\circ C$  to  $+85^\circ C$ , unless otherwise noted. Typical values are at  $V_{CC} = +3.3V$ ,  $V_L = 1.8V$  and  $T_A = +25^\circ C$ .) (Note 1)

PARAMETER	SYMBOL	CONDITIONS	MIN	TYP	MAX	UNITS
I/O $V_{CC\_}$ , CLK_ $V_{CC}$ Rise Time	$t_{RVCC}$	$R_S = 150\Omega$ , $C_{I/OVCC} = 10pF$ , $C_{CLK\_VCC} = 10pF$ , push-pull drivers (Figure 1)			2.5	ns
I/O $V_{CC\_}$ , CLK_ $V_{CC}$ Fall Time	$t_{FVCC}$	$R_S = 150\Omega$ , $C_{I/OVCC} = 10pF$ , $C_{CLK\_VCC} = 10pF$ (Figures 1, 2)			2.5	ns
I/O $V_{L\_}$ , CLK_ $V_L$ Rise Time	$t_{RVL}$	$R_S = 150\Omega$ , $C_{I/OVL} = 15pF$ , $C_{CLK\_VL} = 15pF$ , push-pull drivers (Figure 3)			2.5	ns
I/O $V_{L\_}$ , CLK_ $V_L$ Fall Time	$t_{FVL}$	$R_S = 150\Omega$ , $C_{I/OVL} = 15pF$ , $C_{CLK\_VL} = 15pF$ (Figures 3, 4)			2.5	ns
Propagation Delay (Driving I/O $V_{L\_}$ , CLK_ $V_L$ )	$t_{PVL-VCC}$	$R_S = 150\Omega$ , $C_{I/OVCC} = 10pF$ , $C_{CLK\_VCC} = 10pF$ , push-pull drivers (Figure 1)			6.5	ns
Propagation Delay (Driving I/O $V_{CC\_}$ , CLK_ $V_{CC}$ )	$t_{PVCC-VL}$	$R_S = 150\Omega$ , $C_{I/OVL} = 15pF$ , $C_{CLK\_VL} = 15pF$ , push-pull drivers (Figure 3)			6.5	ns
Channel-to-Channel Skew	$t_{SKEW}$	$R_S = 150\Omega$ , $C_{I/OVCC} = 10pF$ , $C_{I/OVL} = 15pF$			0.8	ns
Propagation Delay from I/O $V_{L\_}$ to I/O $V_{CC\_}$ after EN	$t_{EN-VCC}$	$R_{LOAD} = 1M\Omega$ , $C_{I/OVCC} = 10pF$ (Figure 5) (MAX13030E-MAX13034E)		5		$\mu s$

# 6-Channel High-Speed Logic-Level Translators

## TIMING CHARACTERISTICS (continued)

( $V_{CC} = +2.2V$  to  $+3.6V$ ,  $V_L = +1.62V$  to  $+3.2V$ ,  $C_{I/OVL} \leq 15pF$ ,  $C_{I/OVCC} \leq 15pF$ ,  $R_{SOURCE} = 150\Omega$ ,  $EN = V_L$ , I/O  $V_L$  to I/O  $V_{CC}$  rise/fall time = 3ns,  $T_A = -40^\circ C$  to  $+85^\circ C$ , unless otherwise noted. Typical values are at  $V_{CC} = +3.3V$ ,  $V_L = 1.8V$  and  $T_A = +25^\circ C$ .) (Note 1)

PARAMETER	SYMBOL	CONDITIONS	MIN	TYP	MAX	UNITS
Propagation Delay from I/O $V_{CC}$ to I/O $V_L$ after EN	$t_{EN-VL}$	$R_{LOAD} = 1M\Omega$ , $C_{I/OVL} = 15pF$ (Figure 5) (MAX13030E–MAX13034E)		5		$\mu s$
Maximum Data Rate		Push-pull operation, $R_{SOURCE} = 150\Omega$ , $C_{I/OVCC} = 10pF$ , $C_{I/OVL} = 15pF$ , $C_{CLK\_VCC} = 10pF$ , $C_{CLK\_VL} = 15pF$	100			Mbps

**Note 1:** All units are 100% production tested at  $T_A = +25^\circ C$ . Limits over the operating temperature range are guaranteed by design and not production tested.

**Note 2:**  $V_L$  must be less than or equal to  $V_{CC} - 0.2V$  during normal operation. However,  $V_L$  can be greater than  $V_{CC}$  during startup and shutdown conditions and the part will not latch-up or be damaged.

**Note 3:** Guaranteed by design.

**Note 4:** Input thresholds are referenced to the boost circuit.

MAX13030E–MAX13035E

# 6-Channel High-Speed Logic-Level Translators

## Typical Operating Characteristics

( $V_{CC} = 3.3V$ ,  $V_L = 1.8V$ ,  $C_L = 15pF$ ,  $R_{SOURCE} = 150\Omega$ , data rate = 100Mbps, push-pull driver,  $T_A = +25^\circ C$ , unless otherwise noted.)

**$V_L$  SUPPLY CURRENT vs.  $V_{CC}$  SUPPLY VOLTAGE (DRIVING I/O  $V_L$ ,  $V_L = 1.8V$ )**

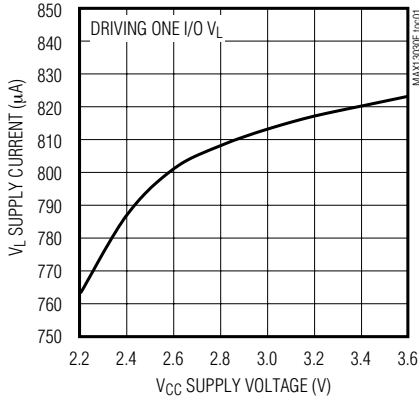

**$V_L$  SUPPLY CURRENT vs.  $V_L$  SUPPLY VOLTAGE (DRIVING I/O  $V_{CC}$ ,  $V_{CC} = 3.6V$ )**

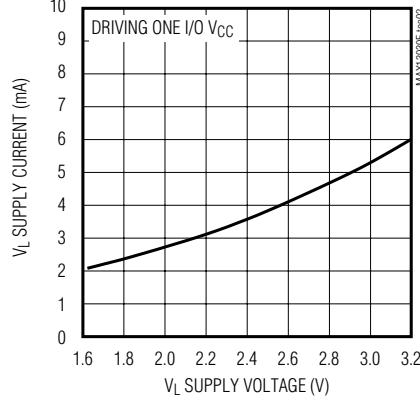

**$V_{CC}$  SUPPLY CURRENT vs.  $V_{CC}$  SUPPLY VOLTAGE (DRIVING I/O  $V_L$ ,  $V_L = 1.8V$ )**

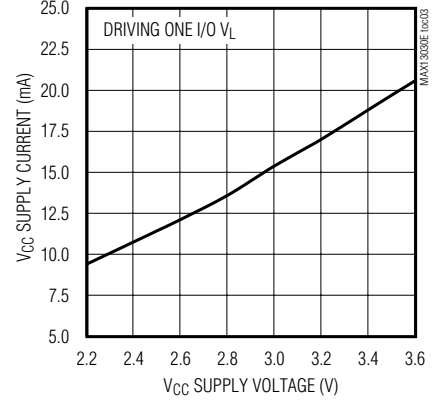

**$V_{CC}$  SUPPLY CURRENT vs.  $V_L$  SUPPLY VOLTAGE (DRIVING I/O  $V_{CC}$ ,  $V_{CC} = 3.6V$ )**

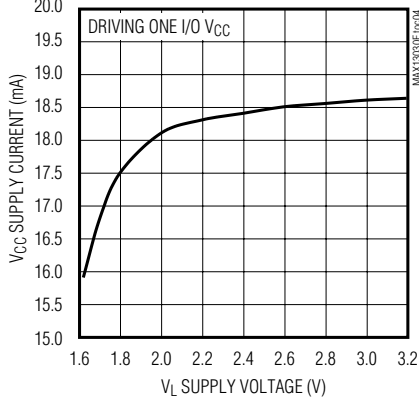

**SUPPLY CURRENT vs. TEMPERATURE (DRIVING I/O  $V_{CC}$ )**

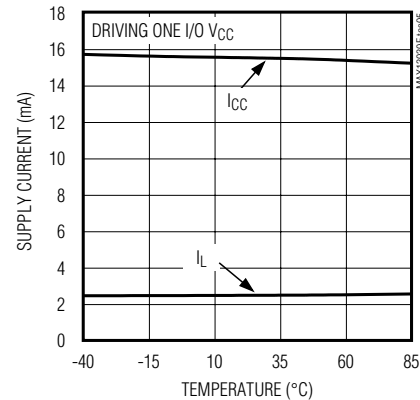

**SUPPLY CURRENT vs. TEMPERATURE (DRIVING I/O  $V_L$ )**

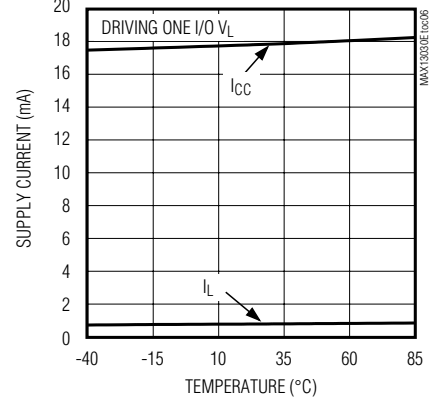

**$V_L$  SUPPLY CURRENT vs. CAPACITIVE LOAD ON I/O  $V_L$  (DRIVING I/O  $V_{CC}$ )**

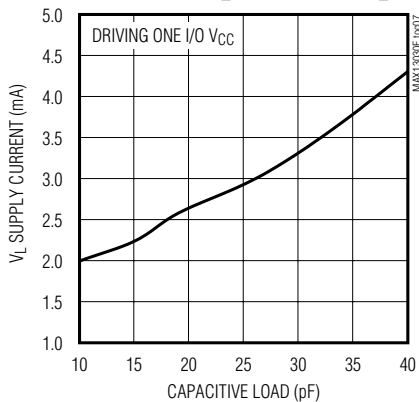

**$V_{CC}$  SUPPLY CURRENT vs. CAPACITIVE LOAD ON I/O  $V_{CC}$  (DRIVING I/O  $V_L$ )**

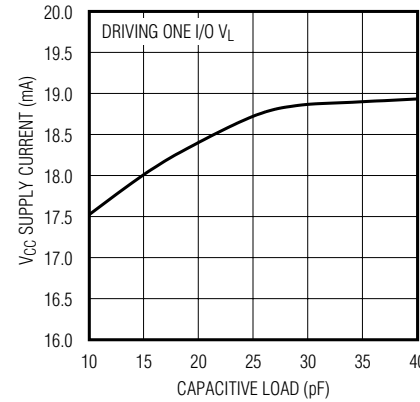

**RISE/FALL TIME vs. CAPACITIVE LOAD ON I/O  $V_{CC}$  (DRIVING I/O  $V_L$ )**

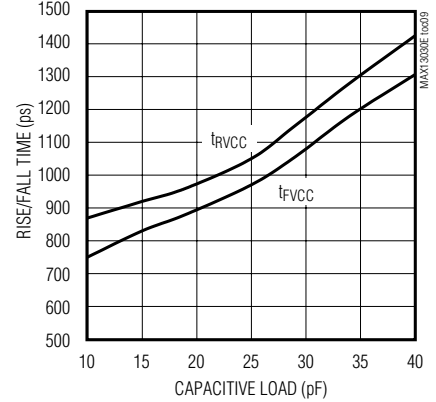

# 6-Channel High-Speed Logic-Level Translators

## Typical Operating Characteristics (continued)

( $V_{CC} = 3.3V$ ,  $V_L = 1.8V$ ,  $C_L = 15pF$ ,  $R_{SOURCE} = 150\Omega$ , data rate = 100Mbps, push-pull driver,  $T_A = +25^\circ C$ , unless otherwise noted.)

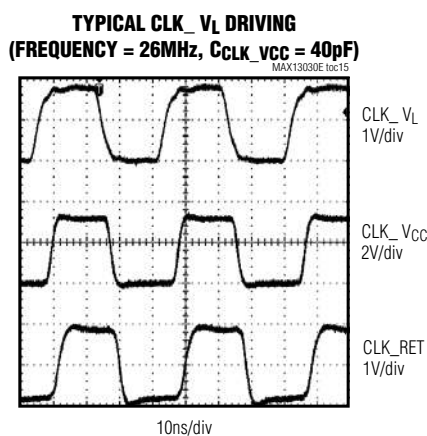
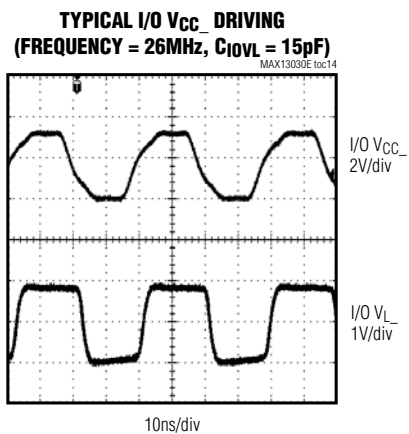
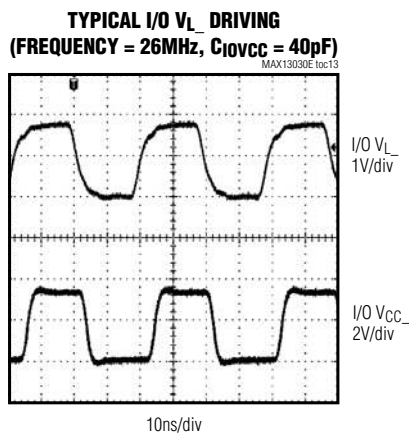
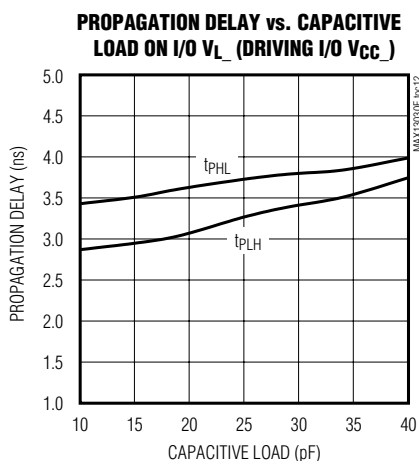
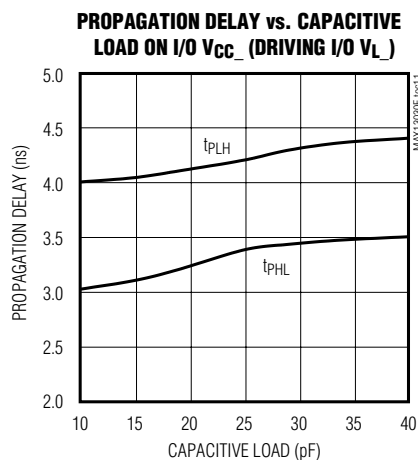
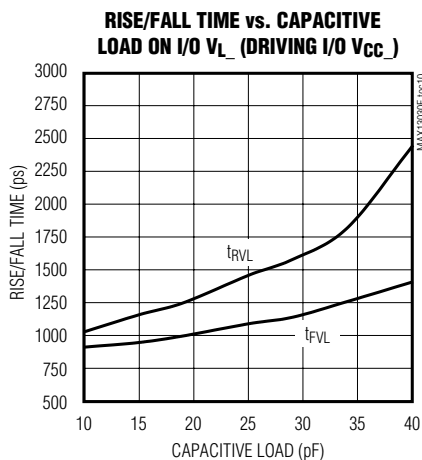

## 6-Channel High-Speed Logic-Level Translators

### Pin Description

PIN				NAME	FUNCTION
MAX13030E-MAX13034E		MAX13035E			
UCSP	TQFN	UCSP	TQFN		
A1	4	A1	4	I/O $V_L3$	Input/Output 3. Referenced to $V_L$ .
A2	6	A2	6	I/O $V_{CC3}$	Input/Output 3. Referenced to $V_{CC}$ .
A3	7	A3	7	I/O $V_{CC4}$	Input/Output 4. Referenced to $V_{CC}$ .
A4	9	A4	9	I/O $V_L4$	Input/Output 4. Referenced to $V_L$ .
B1	3	B1	3	I/O $V_L2$	Input/Output 2. Referenced to $V_L$ .
B2	5	B2	5	I/O $V_{CC2}$	Input/Output 2. Referenced to $V_{CC}$ .
B3	8	B3	8	I/O $V_{CC5}$	Input/Output 5. Referenced to $V_{CC}$ .
B4	10	B4	10	I/O $V_L5$	Input/Output 5. Referenced to $V_L$ .
C1	2	C1	2	$V_L$	Logic-Supply Voltage, +1.62V to +3.2V. Bypass $V_L$ to GND with a 0.1 $\mu$ F capacitor placed as close as possible to the device.
C2	16	C2	16	$V_{CC}$	Power-Supply Voltage, +2.2V to +3.6V. Bypass $V_{CC}$ to GND with a 0.1 $\mu$ F ceramic capacitor. For full ESD protection, connect a 1 $\mu$ F ceramic capacitor from $V_{CC}$ to GND as close as possible to the $V_{CC}$ input.
C3	13	C3	13	GND	Ground
C4	11	—	—	EN	Enable Input. Drive EN to GND for shutdown mode, or drive EN to $V_L$ or $V_{CC}$ for normal operation.
D1	1	D1	1	I/O $V_L1$	Input/Output 1. Referenced to $V_L$ .
D2	15	D2	15	I/O $V_{CC1}$	Input/Output 1. Referenced to $V_{CC}$ .
D3	14	—	—	I/O $V_{CC6}$	Input/Output 6. Referenced to $V_{CC}$ .
D4	12	—	—	I/O $V_L6$	Input/Output 6. Referenced to $V_L$ .
—	—	C4	11	CLK_RET	Clock Return Output. CLK_RET is the returned signal of a clock applied to CLK_ $V_L$ . CLK_RET is referenced to $V_L$ .
—	—	D3	14	CLK_ $V_{CC}$	Translator Channel for a Clock Applied to $V_{CC}$
—	—	D4	12	CLK_ $V_L$	Translator Channel for a Clock Applied to $V_L$
—	EP	—	EP	EP	Exposed Paddle. Connect exposed paddle to GND.



# 6-Channel High-Speed Logic-Level Translators

## Test Circuits/Timing Diagrams

**MAX13030E-MAX13035E**

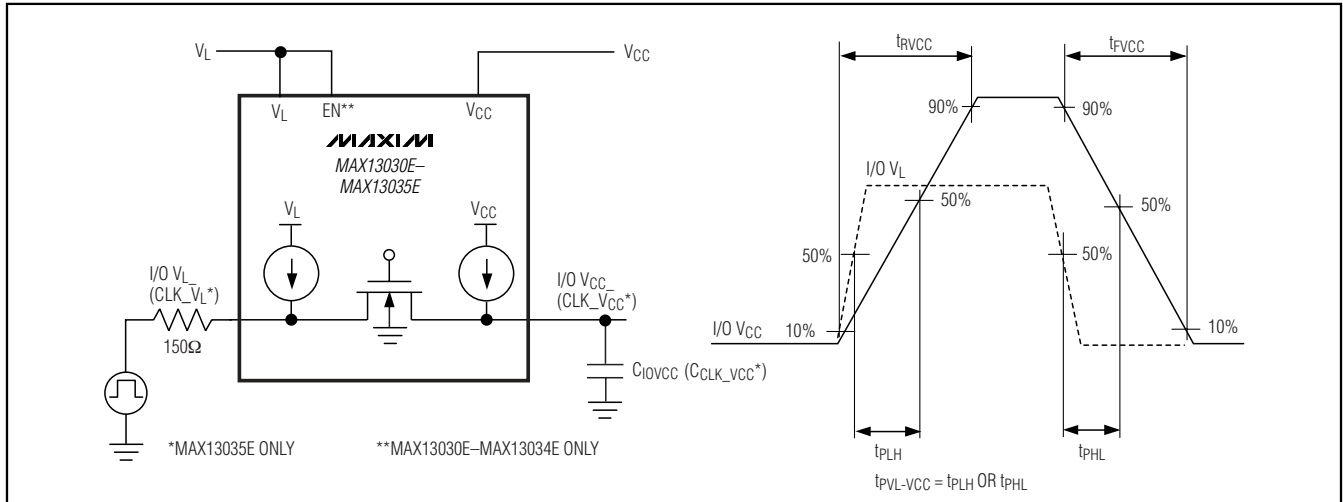

Figure 1. Push-Pull Driving I/O VL\_ Test Circuit and Timing

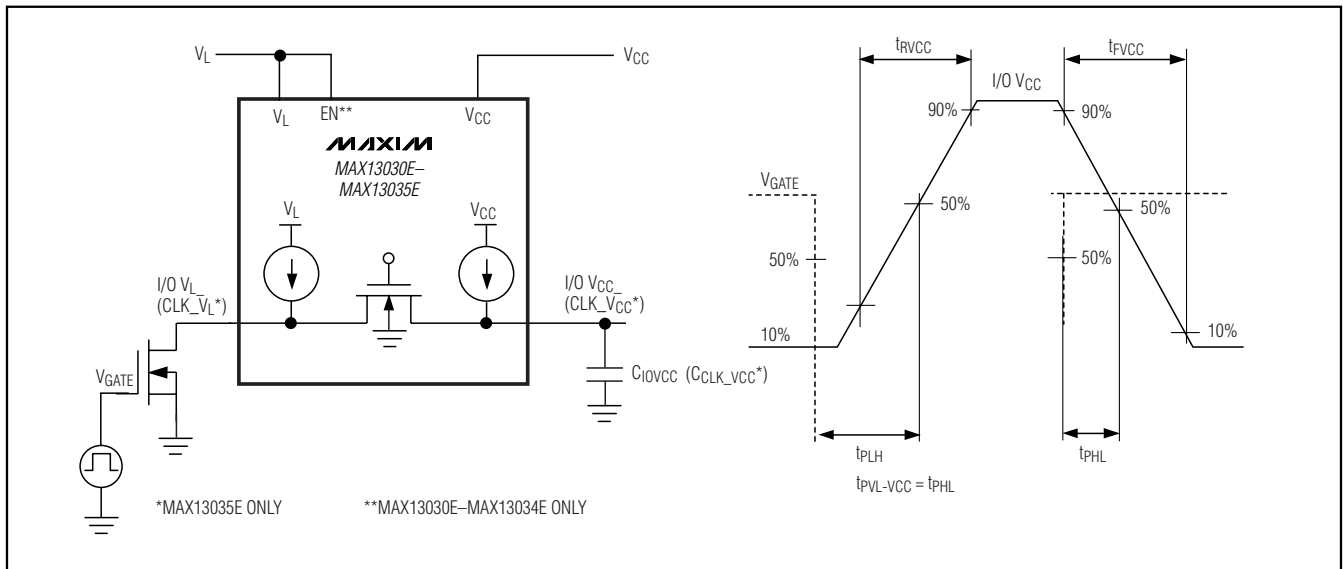

Figure 2. Open-Drain Driving I/O VL\_ Test Circuit and Timing

# 6-Channel High-Speed Logic-Level Translators

## Test Circuits/Timing Diagrams (continued)

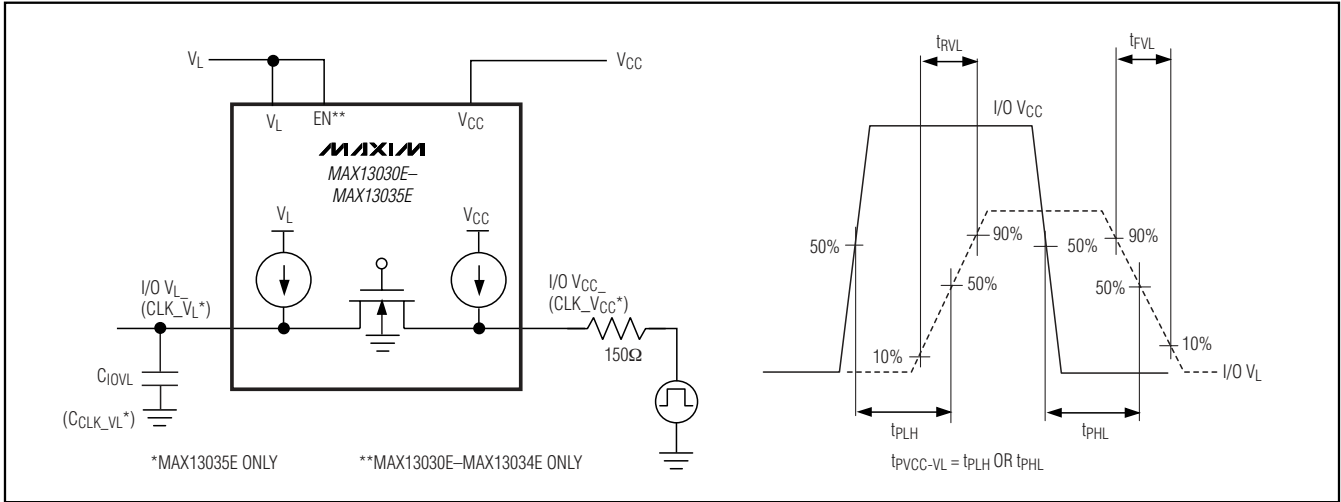

Figure 3. Push-Pull Driving I/O VCC\_ Test Circuit and Timing

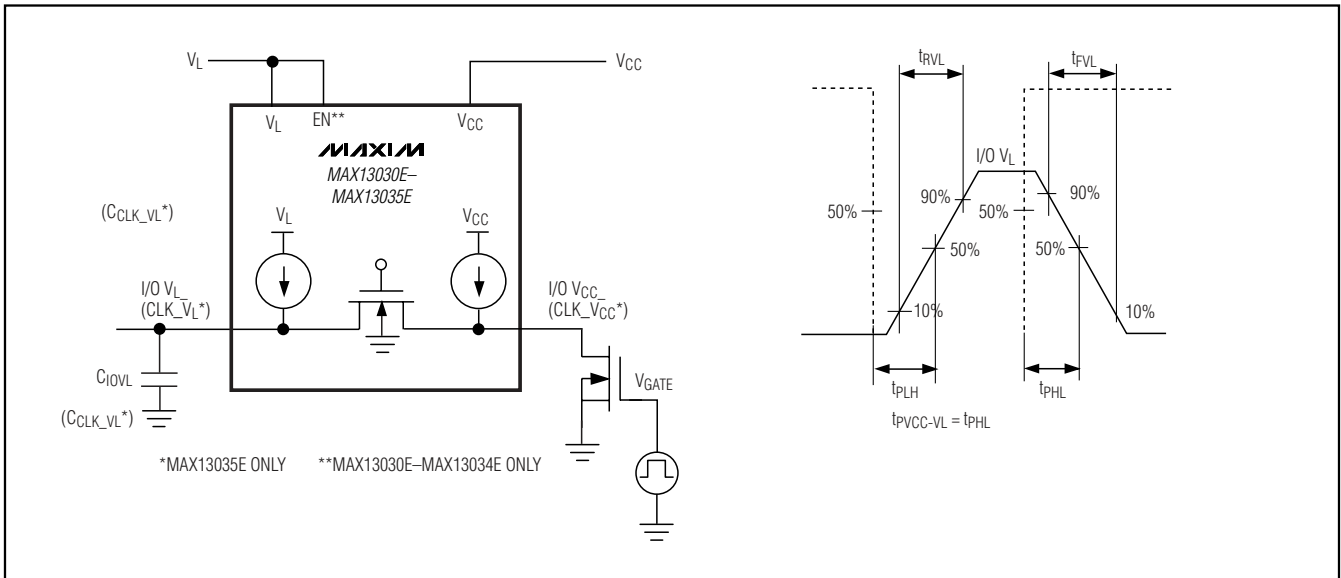

Figure 4. Open-Drain Driving I/O VCC\_ Test Circuit and Timing

# 6-Channel High-Speed Logic-Level Translators

## Test Circuits/Timing Diagrams (continued)

**MAX13030E-MAX13035E**

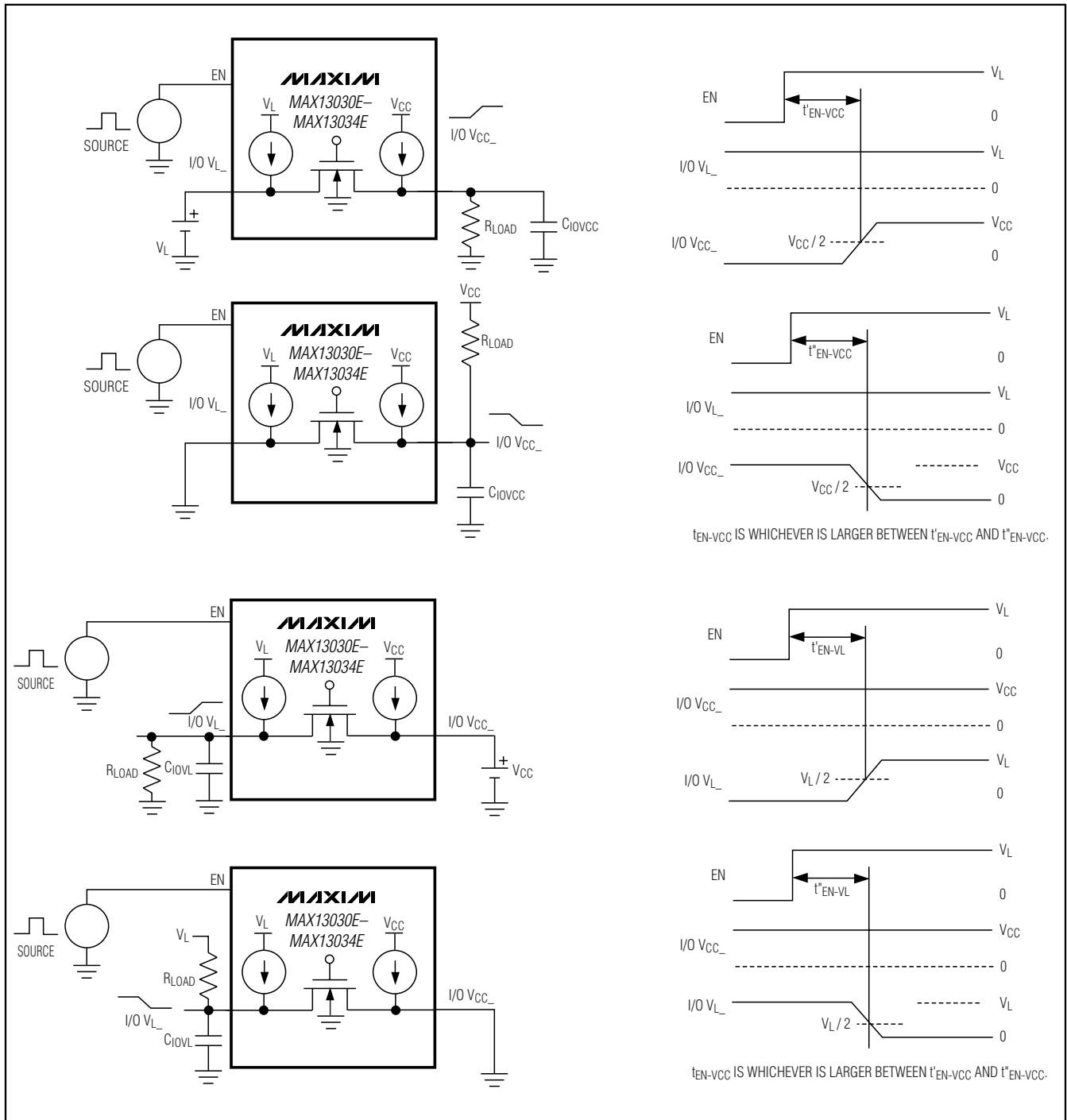

Figure 5. Enable Test Circuit and Timing

## 6-Channel High-Speed Logic-Level Translators

### Detailed Description

The MAX13030E–MAX13035E 6-channel, bidirectional level translators provide the level shifting necessary for 100Mbps data transfer in multivoltage systems. The MAX13030E–MAX13035E are ideally suited for memory card level translation, as well as generic level translation in systems with six channels. Externally applied voltages,  $V_{CC}$  and  $V_L$ , set the logic levels on either side of the device. Logic signals present on the  $V_L$  side of the device appear as a higher voltage logic signal on the  $V_{CC}$  side of the device, and vice versa. The MAX13035E features a CLK\_RET output that returns the same clock signal applied to the CLK\_VL input.

The MAX13030E–MAX13035E operate at full speed with external drivers that source as little as 4mA output current. Each I/O channel is pulled up to  $V_{CC}$  or  $V_L$  by an internal  $30\mu\text{A}$  current source, allowing the MAX13030E–MAX13035E to be driven by either push-pull or open-drain drivers.

The MAX13030E–MAX13034E feature an enable (EN) input that places the device into a low-power shutdown mode when driven low. The MAX13030E–MAX13035E features an automatic shutdown mode that disables the part when  $V_{CC}$  is less than  $V_L$ . The state of I/O  $V_{CC}$  and I/O  $V_L$  during shutdown is chosen by selecting the appropriate part version (see *Ordering Information/Selector Guide*).

The MAX13030E–MAX13035E accept  $V_{CC}$  voltages from +2.2V to +3.6V and  $V_L$  voltages from +1.62V to +3.2V.

### Level Translation

For proper operation, ensure that  $+2.2\text{V} \leq V_{CC} \leq +3.6\text{V}$ , and  $+1.62\text{V} \leq V_L \leq V_{CC} - 0.2\text{V}$ . When power is supplied to  $V_L$  while  $V_{CC}$  is either missing or less than  $V_L$ , the MAX13030E–MAX13035E automatically enters a low-power mode. In addition, the MAX13030E–MAX13034E enters a low-power mode if  $\text{EN} = 0\text{V}$ . This allows  $V_{CC}$  to be disconnected and still have a known state on I/O  $V_L$ . The maximum data rate depends heavily on the load capacitance (see the *Typical Operating Characteristics Rise/Fall Times*), output impedance of the driver, and the operating voltage range.

### Input Driver Requirements

The MAX13030E–MAX13035E architecture is based on an nMOS pass gate and output accelerator stages (see Figure 6). Output accelerator stages are always in tri-state mode except when there is a transition on any of the translators on the input side, either I/O  $V_L$ , CLK\_VL, I/O  $V_{CC}$ , or CLK\_VCC. A short pulse is then generated during which the output accelerator stages become active and charge/discharge the capacitances at the I/Os. Due to its architecture, both input stages become

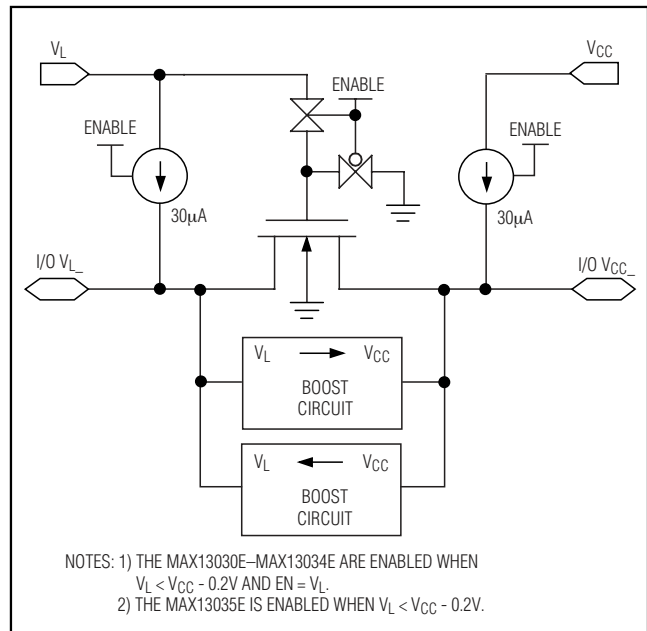

Figure 6. Simplified Functional Diagram for One I/O Line

active during the one-shot pulse. This can lead to some current feeding into the external source that is driving the translator. However, this behavior helps to speed up the transition on the driven side.

The MAX13030E–MAX13035E have internal current sources capable of sourcing  $30\mu\text{A}$  to pullup the I/O lines. These internal pullup current sources allow the inputs to be driven with open-drain drivers, as well as push-pull drivers. It is not recommended to use external pullup resistors on the I/O lines. The architecture of the MAX13030E–MAX13035E permit either side to be driven with a minimum of 4mA drivers or larger.

### Output Load Requirements

The MAX13030E–MAX13035E I/O are designed to drive CMOS inputs. Do not load the I/O lines with a resistive load less than  $25\text{k}\Omega$  and do not place an RC circuit at the input of these devices to slow down the edges. If a slower rise/fall time is required, refer to the MAX3000E/MAX3001E logic-level translator datasheet. For I<sup>2</sup>C level translation, refer to the MAX3372E–MAX3379E/MAX3390E–MAX3393E datasheet.

### Shutdown Mode

The MAX13030E–MAX13034E feature an enable (EN) input that places the device into a low-power shutdown mode when driven low. The MAX13030E–MAX13035E features an automatic shutdown mode that disables the part when  $V_{CC}$  is missing or less than  $V_L$ .

## 6-Channel High-Speed Logic-Level Translators

### Clock Return (CLK\_RET)

The MAX13035E features a CLK\_RET output that returns the clock signal applied to CLK\_VL. CLK\_VL and CLK\_VCC are identical to the other I/O channels, the only difference being that CLK\_VCC is internally tied to the VCC side of CLK\_RET (see the *Functional Diagram*).

### Application Information

#### Layout Recommendations

Use standard high-speed layout practices when laying out a board with the MAX13030E–MAX13035E. For example, to minimize line coupling, place all other signal lines not connected to the MAX13030E–MAX13035E at least 1x the substrate height of the PCB away from the input and output lines of the MAX13030E–MAX13035E.

#### Power-Supply Decoupling

To reduce ripple and the chance of introducing data errors, bypass VL and VCC to ground with 0.1µF ceramic capacitors. Place all capacitors as close as possible to the power-supply inputs. For full ESD protection, bypass VCC with a 1µF ceramic capacitor located as close as possible to the VCC input.

#### Unidirectional vs. Bidirectional Level Translator

The MAX13030E–MAX13035E bidirectional level translators can operate as a unidirectional device to translate signals without inversion. These devices provide the smallest solution (UCSP package) for unidirectional level translation without inversion.

#### Use with External Pullup/Pulldown Resistors

Due to the architecture of the MAX13030E–MAX13035E, it is not recommended to use external pullup or pulldown resistors on the bus. In certain applications, the use of external pullup or pulldown resistors is desired to have a known bus state when there is no active driver on the bus. For example, this may happen when interfacing to a memory card slot with no memory card inserted. The MAX13030E–MAX13035E include internal pullup current sources that set the bus state when the device is enabled. In shutdown mode, the state of I/O VCC\_ and I/O VL\_ is dependent on the selected part version (see *Ordering Information/Selector Guide* for further information).

### Open-Drain Signaling

The MAX13030E–MAX13035E are designed to pass open-drain as well as CMOS push-pull signals. When used with open-drain signaling, the rise time is dominated by the interaction of the internal pullup current source and the parasitic load capacitance. The MAX13030E–MAX13035E include internal rise time accelerators to speed up transitions, eliminating any need for external pullup resistors.

### SD Card Detection

SD, MiniSD, MMC and similar types of cards provide detection of a card through a pullup resistor on one of the DAT lines, or by use of a mechanical switch. This pullup resistor is internal to the memory card itself. The MAX13030E–MAX13035E only support detection of a memory card through a mechanical switch, and it is recommended that the internal resistor for card detection be switched off by the command interface. For example, when using SD cards, the command SET\_CLR\_CARD\_DETECT (ACMD42) disables this resistor.

### UCSP Applications Information

For the latest application details on UCSP construction, dimensions, tape carrier information, PCB techniques, bump-pad layout, and recommended reflow temperature profiles, as well as the latest information on reliability testing results, go to Maxim's web site at [www.maxim-ic.com/ucsp](http://www.maxim-ic.com/ucsp) to find the Application Note: *UCSP – A Wafer-Level Chip-Scale Package*.

### Chip Information

Process: BiCMOS

# 6-Channel High-Speed Logic-Level Translators

Functional Diagram

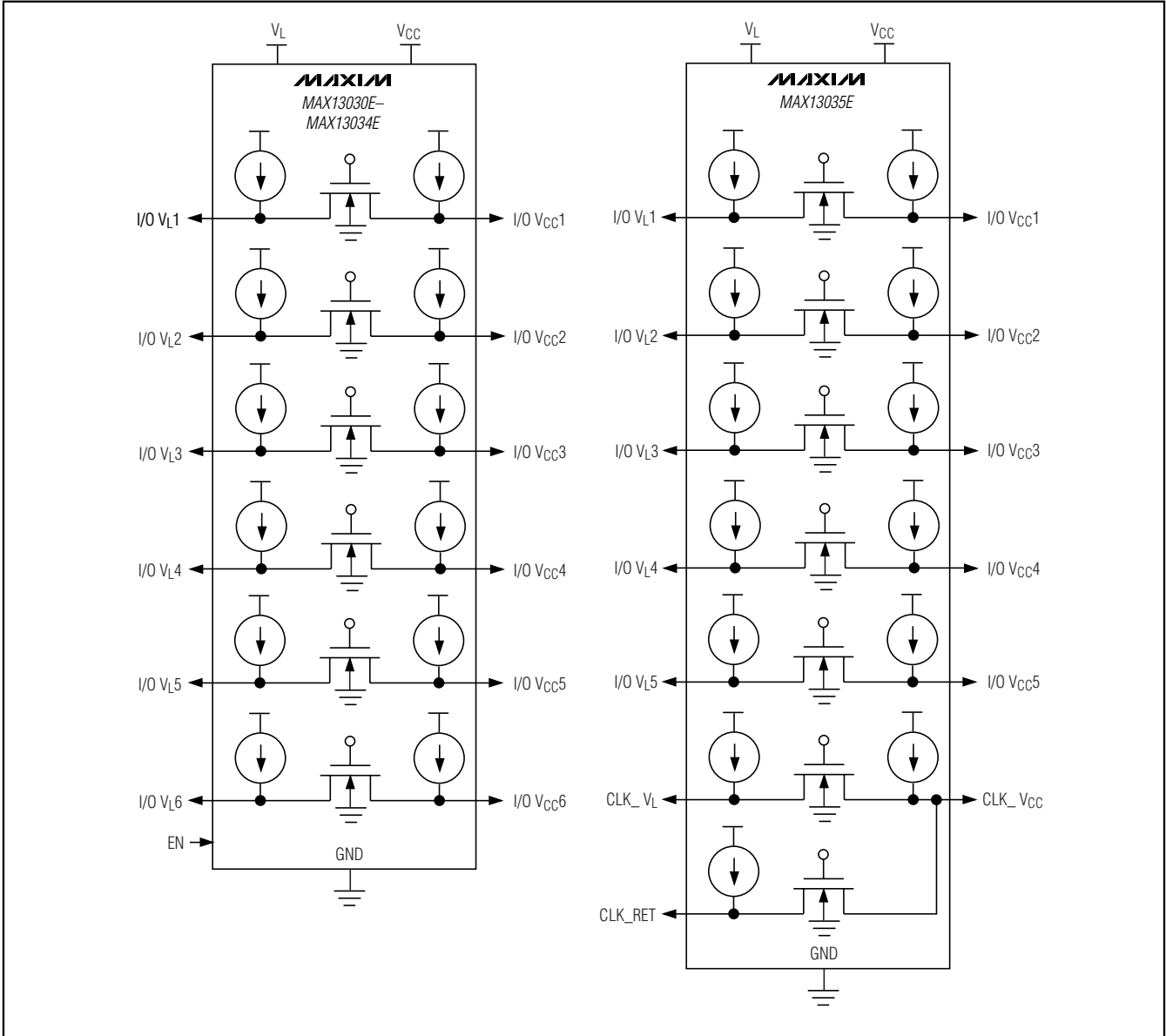

# 6-Channel High-Speed Logic-Level Translators

## Pin Configurations

**MAX13030E-MAX13035E**

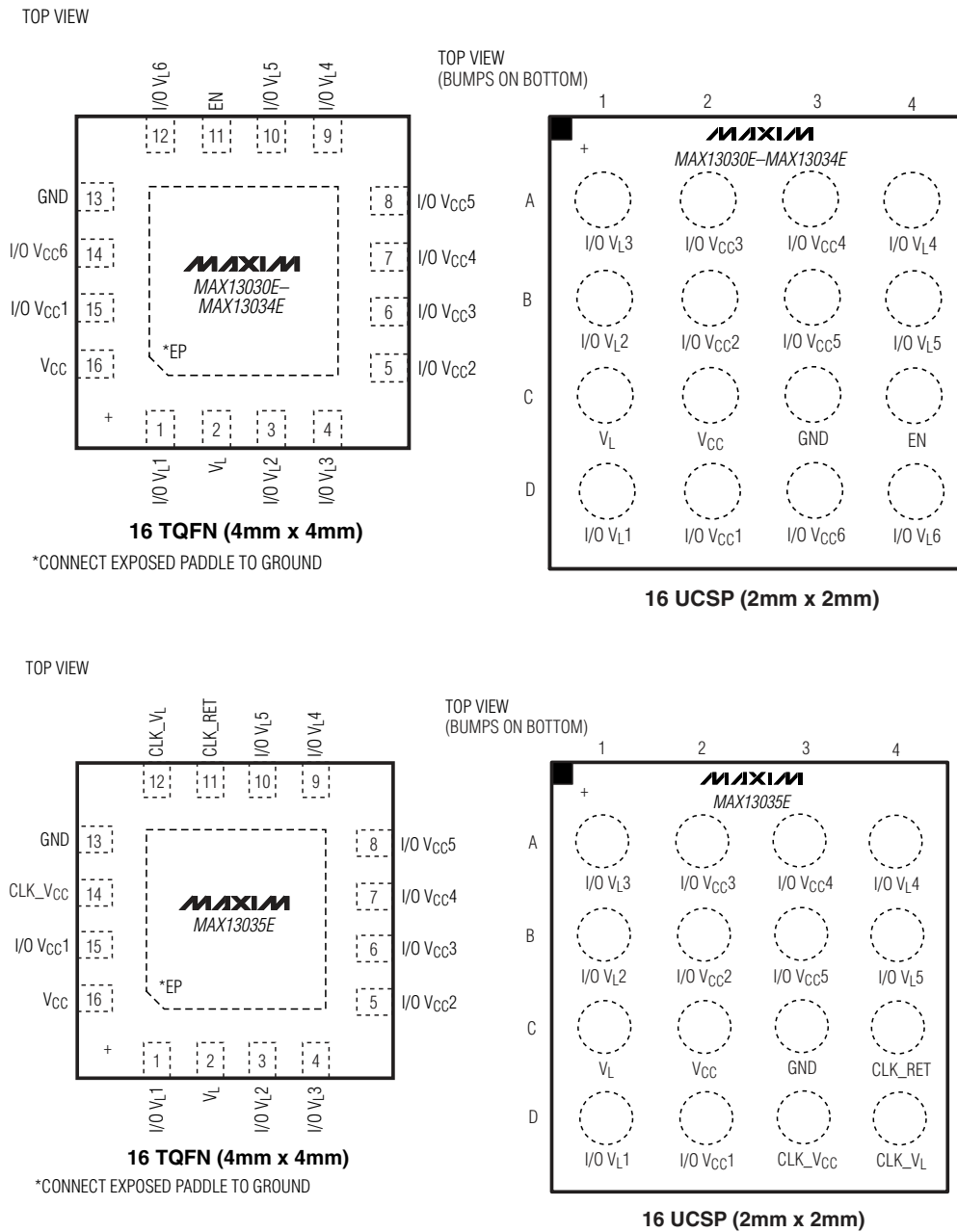

# 6-Channel High-Speed Logic-Level Translators

## Typical Operating Circuits (continued)

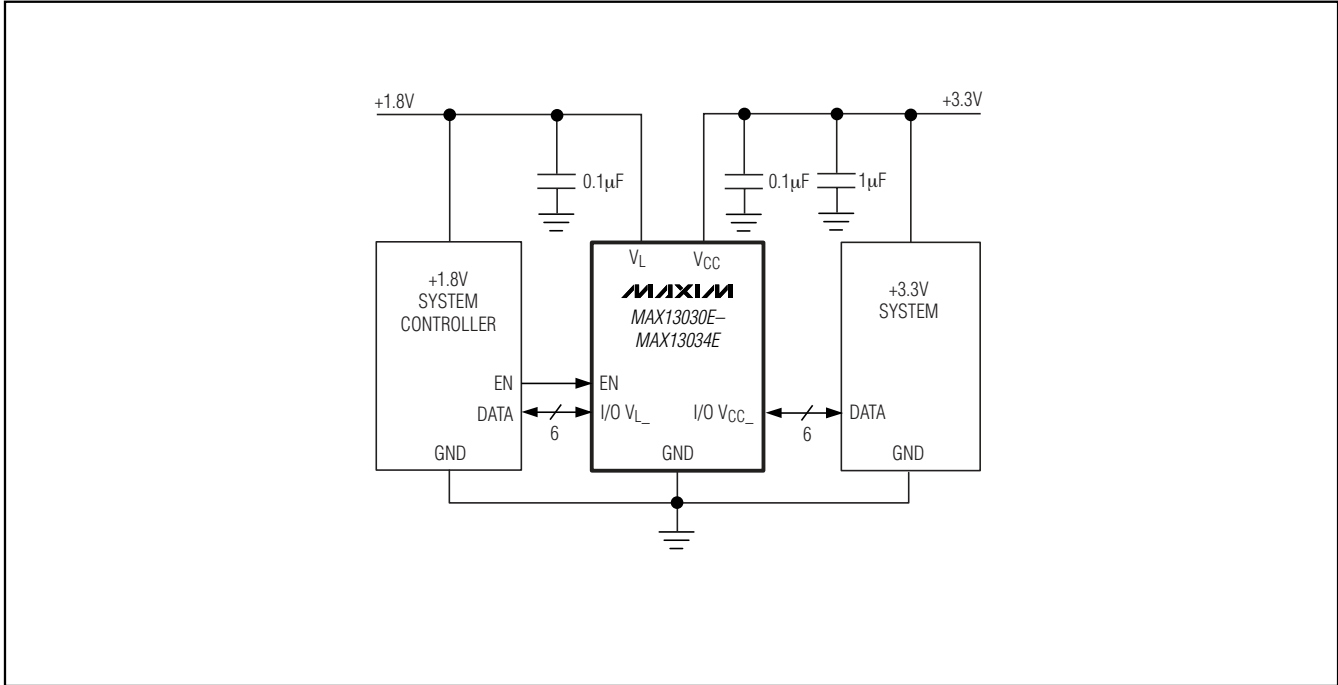

## Ordering Information/Selector Guide (continued)

PART	PIN-PACKAGE	I/O V <sub>L</sub> STATE DURING SHUTDOWN	I/O V <sub>CC</sub> STATE DURING SHUTDOWN	PKG CODE
<b>MAX13031E</b> EBE+*	16 UCSP	High impedance	16.5kΩ to V <sub>CC</sub>	B16-1
MAX13031EETE+*	16 TQFN-EP**	High impedance	16.5kΩ to V <sub>CC</sub>	T1644-4
<b>MAX13032E</b> EBE+	16 UCSP	High impedance	16.5kΩ to GND	B16-1
MAX13032EETE+	16 TQFN-EP**	High impedance	16.5kΩ to GND	T1644-4
<b>MAX13033E</b> EBE+*	16 UCSP	16.5kΩ to GND	High impedance	B16-1
MAX13033EETE+*	16 TQFN-EP**	16.5kΩ to GND	High impedance	T1644-4
<b>MAX13034E</b> EBE+*	16 UCSP	16.5kΩ to GND	16.5kΩ to GND	B16-1
MAX13034EETE+*	16 TQFN-EP**	16.5kΩ to GND	16.5kΩ to GND	T1644-4
<b>MAX13035E</b> EBE+	16 UCSP	75kΩ to V <sub>L</sub>	High impedance	B16-1
MAX13035EETE+	16 TQFN-EP**	75kΩ to V <sub>L</sub>	High impedance	T1644-4

**Note:** All devices are specified over the -40°C to +85°C operating temperature range.

+Denotes a lead-free package.

\*\*EP = Exposed paddle.



# 6-Channel High-Speed Logic-Level Translators

## Package Information

(The package drawing(s) in this data sheet may not reflect the most current specifications. For the latest package outline information, go to [www.maxim-ic.com/packages](http://www.maxim-ic.com/packages).)

MAX13030E-MAX13035E

**TOP VIEW**

COMMON DIMENSIONS		VARIABLE DIMENSIONS		DEPOPULATED SOLDER BALLS
		D	E	
A	0.62±0.05-0.08	B16-1	2.02±0.05	NONE
A1	0.29±0.02	B16-2	2.02±0.05	B3, C3
A2	0.33 REF.	B16-3	2.02±0.05	B3, C2
b	∅0.35±0.03	B16-4	2.02±0.05	B2, C3
D1	1.50 BASIC	B16-5	2.02±0.05	B2, B3, C2, C3
E1	1.50 BASIC	B16-6	2.02±0.05	C3
e	0.50 BASIC			
SD	0.25 BASIC			
SE	0.25 BASIC			

**NOTES:**

- ALL DIMENSIONS ARE IN MILLIMETERS.
- PRODUCT MARKING: NUMBER OF CHARACTERS AND LINES VARY PER PRODUCT.

**BOTTOM VIEW**

**SIDE VIEW**

**DALLAS SEMICONDUCTOR** **MAXIM**

PROPRIETARY INFORMATION

TITLE: PACKAGE OUTLINE, 4x4 UCSP

APPROVAL	DOCUMENT CONTROL NO. 21-0101	REV. H 1/1
----------	------------------------------	------------

16LUCSP.EPS

# 6-Channel High-Speed Logic-Level Translators

## Package Information (continued)

(The package drawing(s) in this data sheet may not reflect the most current specifications. For the latest package outline information, go to [www.maxim-ic.com/packages](http://www.maxim-ic.com/packages).)

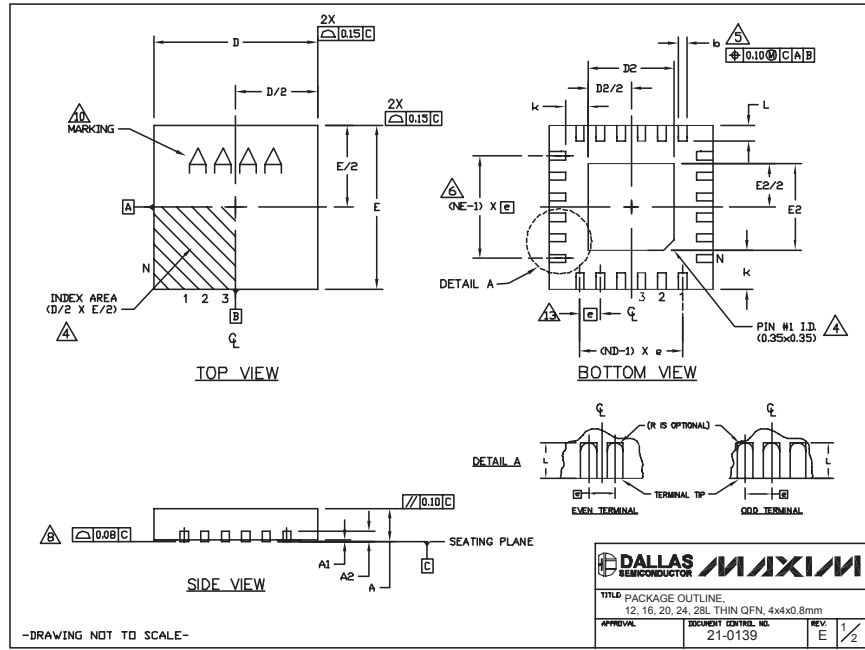

24L QFN THINLEPS

COMMON DIMENSIONS															
PKG	12L 4x4			16L 4x4			20L 4x4			24L 4x4			28L 4x4		
REF.	MIN.	NOM.	MAX.	MIN.	NOM.	MAX.	MIN.	NOM.	MAX.	MIN.	NOM.	MAX.	MIN.	NOM.	MAX.
A	0.70	0.75	0.80	0.70	0.75	0.80	0.70	0.75	0.80	0.70	0.75	0.80	0.70	0.75	0.80
A1	0.0	0.02	0.05	0.0	0.02	0.05	0.0	0.02	0.05	0.0	0.02	0.05	0.0	0.02	0.05
A2	0.20 REF			0.20 REF			0.20 REF			0.20 REF			0.20 REF		
b	0.25	0.30	0.35	0.25	0.30	0.35	0.20	0.25	0.30	0.18	0.23	0.30	0.15	0.20	0.25
D	3.90	4.00	4.10	3.90	4.00	4.10	3.90	4.00	4.10	3.90	4.00	4.10	3.90	4.00	4.10
E	3.90	4.00	4.10	3.90	4.00	4.10	3.90	4.00	4.10	3.90	4.00	4.10	3.90	4.00	4.10
e	0.80 BSC			0.65 BSC			0.50 BSC			0.50 BSC			0.40 BSC		
k	0.25	-	-	0.25	-	-	0.25	-	-	0.25	-	-	0.25	-	-
L	0.45	0.55	0.65	0.45	0.55	0.65	0.45	0.55	0.65	0.30	0.40	0.50	0.30	0.40	0.50
N	12			16			20			24			28		
ND	3			4			5			6			7		
NE	3			4			5			6			7		
POSE	VGG8			VGGC			WGGD-1			WGGD-2			VGGE		
WV	VGG8			VGGC			WGGD-1			WGGD-2			VGGE		

EXPOSED PAD VARIATIONS												
PKG CODES	D2			E2			DOWN BONDS ALLOWED					
	MIN.	NOM.	MAX.	MIN.	NOM.	MAX.						
T1244-3	1.95	2.10	2.25	1.95	2.10	2.25	YES					
T1244-4	1.95	2.10	2.25	1.95	2.10	2.25	NO					
T1644-3	1.95	2.10	2.25	1.95	2.10	2.25	YES					
T1644-4	1.95	2.10	2.25	1.95	2.10	2.25	NO					
T2044-2	1.95	2.10	2.25	1.95	2.10	2.25	YES					
T2044-3	1.95	2.10	2.25	1.95	2.10	2.25	NO					
T2444-2	1.95	2.10	2.25	1.95	2.10	2.25	YES					
T2444-3	2.45	2.60	2.63	2.45	2.60	2.63	YES					
T2444-4	2.45	2.60	2.63	2.45	2.60	2.63	NO					
T2844-1	2.50	2.60	2.70	2.50	2.60	2.70	NO					

NOTES:

- DIMENSIONING & TOLERANCING CONFORM TO ASME Y14.5M-1994.
- ALL DIMENSIONS ARE IN MILLIMETERS. ANGLES ARE IN DEGREES.
- N IS THE TOTAL NUMBER OF TERMINALS.
- THE TERMINAL #1 IDENTIFIER AND TERMINAL NUMBERING CONVENTION SHALL CONFORM TO JEDEC 95-1 SFP-012. DETAILS OF TERMINAL #1 IDENTIFIER ARE OPTIONAL, BUT MUST BE LOCATED WITHIN THE ZONE INDICATED. THE TERMINAL #1 IDENTIFIER MAY BE EITHER A MOLD OR MARKED FEATURE.
- DIMENSION b APPLIES TO METALLIZED TERMINAL AND IS MEASURED BETWEEN 0.25 mm AND 0.30 mm FROM TERMINAL TP.
- ND AND NE REFER TO THE NUMBER OF TERMINALS ON EACH D AND E SIDE RESPECTIVELY.
- DEPOPULATION IS POSSIBLE IN A SYMMETRICAL FASHION.
- COPLANARITY APPLIES TO THE EXPOSED HEAT SINK SLUG AS WELL AS THE TERMINALS.
- DRAWING CONFORMS TO JEDEC MO220, EXCEPT FOR T2444-3, T2444-4 AND T2844-1.
- MARKING IS FOR PACKAGE ORIENTATION REFERENCE ONLY.
- COPLANARITY SHALL NOT EXCEED 0.08mm
- WARPAGE SHALL NOT EXCEED 0.10mm
- LEAD CENTERLINES TO BE AT TRUE POSITION AS DEFINED BY BASIC DIMENSION "e", ±0.05.
- NUMBER OF LEADS SHOWN ARE FOR REFERENCE ONLY

Maxim cannot assume responsibility for use of any circuitry other than circuitry entirely embodied in a Maxim product. No circuit patent licenses are implied. Maxim reserves the right to change the circuitry and specifications without notice at any time.

Maxim &gt; Products &gt; Interface and Interconnect

# MAX13030E, MAX13031E\*, MAX13032E, MAX13033E\*, MAX13034E\*, MAX13035E

6-Channel High-Speed Logic-Level Translators

## High-Speed (100Mbps), 6-Channel Translators Compatible with 4mA Drivers

### \* Future Product

- For automatic e-mail on new parts in this product line, [subscribe to EE-Mail](#)

QuickView

Technical Documents

Ordering Info

More Information

All

### Ordering Information

Notes:

- Other options and links for purchasing parts are listed at: <http://www.maxim-ic.com/sales>.
- [Didn't Find What You Need?](#) Ask our applications engineers. Expert assistance in finding parts, usually within one business day.
- Part number suffixes: T or T&R = tape and reel; + = RoHS/lead-free; # = RoHS/lead-exempt. More: See [Full Data Sheet](#) or [Part Naming Conventions](#).
- \* Some packages have variations, listed on the drawing. "PkgCode/Variation" tells which variation the product uses.

Devices: 1-12 of 12

MAX13030E	Free Sample	Buy	Package: TYPE PINS FOOTPRINT DRAWING CODE/VAR *	Temp	RoHS/Lead-Free? Materials Analysis
MAX13030EETE+T			THIN QFN;16 pin;17 mm Dwg: <a href="#">21-0139G</a> (PDF) Use pkgcode/variation: T1644+4*	-40C to +85C	RoHS/Lead-Free: <a href="#">Lead Free Materials Analysis</a>
MAX13030EETE+			THIN QFN;16 pin;17 mm Dwg: <a href="#">21-0139G</a> (PDF) Use pkgcode/variation: T1644+4*	-40C to +85C	RoHS/Lead-Free: <a href="#">Lead Free Materials Analysis</a>
MAX13030EEBE+			UCSP;16 pin;4 mm Dwg: <a href="#">21-0101H</a> (PDF) Use pkgcode/variation: B16+1*	-40C to +85C	RoHS/Lead-Free: <a href="#">Lead Free Materials Analysis</a>
MAX13030EEBE+T			UCSP;16 pin;4 mm Dwg: <a href="#">21-0101H</a> (PDF) Use pkgcode/variation: B16+1*	-40C to +85C	RoHS/Lead-Free: <a href="#">Lead Free Materials Analysis</a>
MAX13032E	Free Sample	Buy	Package: TYPE PINS FOOTPRINT DRAWING CODE/VAR *	Temp	RoHS/Lead-Free? Materials Analysis
MAX13032EETE+T			THIN QFN;16 pin;17 mm Dwg: <a href="#">21-0139G</a> (PDF) Use pkgcode/variation: T1644+4*	-40C to +85C	RoHS/Lead-Free: <a href="#">Lead Free Materials Analysis</a>
MAX13032EETE+			THIN QFN;16 pin;17 mm Dwg: <a href="#">21-0139G</a> (PDF) Use pkgcode/variation: T1644+4*	-40C to +85C	RoHS/Lead-Free: <a href="#">Lead Free Materials Analysis</a>
MAX13032EEBE+			UCSP;16 pin;4 mm Dwg: <a href="#">21-0101H</a> (PDF) Use pkgcode/variation: B16+1*	-40C to +85C	RoHS/Lead-Free: <a href="#">Lead Free Materials Analysis</a>
MAX13032EEBE+T			UCSP;16 pin;4 mm Dwg: <a href="#">21-0101H</a> (PDF) Use pkgcode/variation: B16+1*	-40C to +85C	RoHS/Lead-Free: <a href="#">Lead Free Materials Analysis</a>
MAX13035E	Free Sample	Buy	Package: TYPE PINS FOOTPRINT DRAWING CODE/VAR *	Temp	RoHS/Lead-Free? Materials Analysis

MAX13035EETE+T			THIN QFN;16 pin;17 mm Dwg: <a href="#">21-0139G (PDF)</a> Use pkgcode/variation: T1644+4*	-40C to +85C	RoHS/Lead-Free: <a href="#">Lead Free Materials Analysis</a>
MAX13035EETE+			THIN QFN;16 pin;17 mm Dwg: <a href="#">21-0139G (PDF)</a> Use pkgcode/variation: T1644+4*	-40C to +85C	RoHS/Lead-Free: <a href="#">Lead Free Materials Analysis</a>
MAX13035EEBE+T			UCSP;16 pin;4 mm Dwg: <a href="#">21-0101H (PDF)</a> Use pkgcode/variation: B16+1*	-40C to +85C	RoHS/Lead-Free: <a href="#">Lead Free Materials Analysis</a>
MAX13035EEBE+			UCSP;16 pin;4 mm Dwg: <a href="#">21-0101H (PDF)</a> Use pkgcode/variation: B16+1*	-40C to +85C	RoHS/Lead-Free: <a href="#">Lead Free Materials Analysis</a>

### Didn't Find What You Need?

- [Next Day Product Selection Assistance from Applications Engineers](#)
- [Parametric Search](#)
- [Applications Help](#)

#### QuickView

[Description](#)  
[Key Features](#)  
[Applications/Uses](#)  
[Key Specifications](#)  
[Diagram](#)

#### Technical Documents

[Data Sheet](#)  
[Application Notes](#)  
[Design Guides](#)  
[Engineering Journals](#)  
[Reliability Reports](#)  
[Software/Models](#)  
[Evaluation Kits](#)

#### Ordering Info

[Price and Availability](#)  
[Samples](#)  
[Buy Online](#)  
[Package Information](#)  
[Lead-Free Information](#)

#### More Information

[Related Products](#)  
[Notes and Comments](#)  
[Evaluation Kits](#)

Document Ref.: 19-0626; Rev 0; 2007-02-12  
This page last modified: 2007-02-12

[CONTACT US: SEND US AN EMAIL](#)