

THIS DRAWING IS UNPUBLISHED. RELEASED FOR PUBLICATION NOV. 2001.
 © COPYRIGHT 2001 By - ALL RIGHTS RESERVED.

LOC	DIST	REVISIONS					
J		P	LTR	DESCRIPTION	DATE	DWN	APVD
			D2	REVISED PER ECO-11-005033	31MAR11	RK	HMR

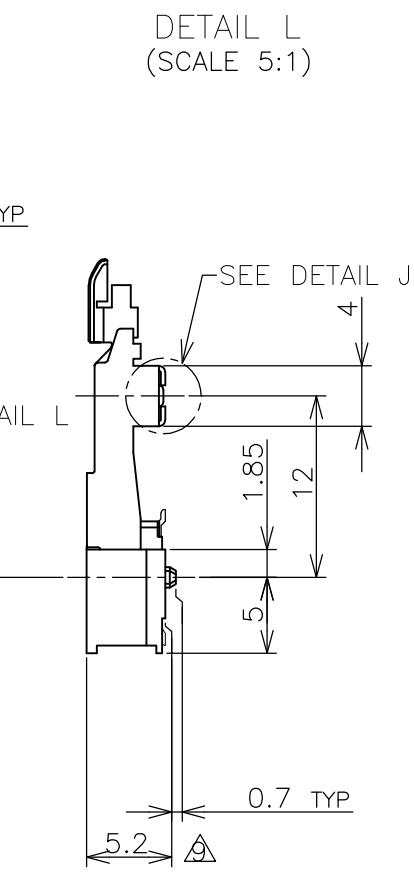

- (APPLIED TO SHEET 1-2)
- MATERIAL ; HOUSING: HIGH TEMPERATURE THERMO PLASTIC UL94V-0
 CONTACT: COPPER ARROY
 LOCK LEVER: STAINLESS STEEL
 SOLDER PEG: COPPER ARROY
 - FINISH ; CONTACT AREA: GOLD FLASH ON 0.0013MIN ALL OVER NICKEL.
 SOLDERING AREA: GOLD FLASH PLT.
 SOLDER PEG: TIN PLATING.
- MECHANICAL KEY POSITION OF CONNECTOR SEE TABLE.
 - TOLERANCES NON-CUMULATIVE.
 - NOT TO SCALE.
 - INSIDE MUST BE RESIST COAT EXCEPT SOLDER PATTERN.
 - COPLANARITY : 0.1 MAX.
 - THE FLOATING VALUE BY SOLDERING IS NOT INCLUDED.
 - NOT MATING CONDITION.
 - IF THE MODULE DOESN'T INSERT AND LOCK IN THE LATCH SMOOTHLY, OPEN WIDE BOTH LATCHES BY MANUAL. AND THE MODULE MUST BE INSERTED AND LOCKED IN THE LATCH.

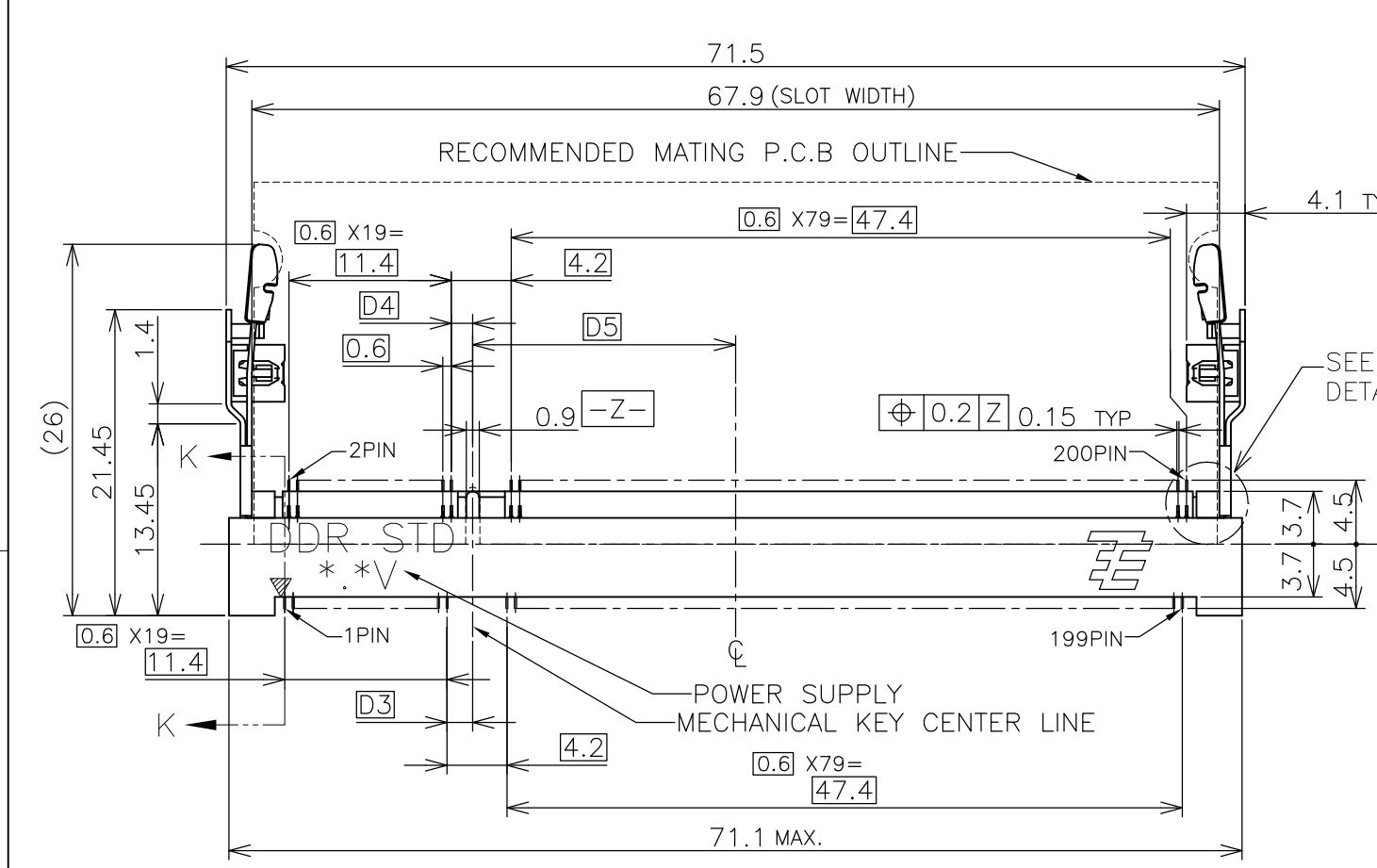
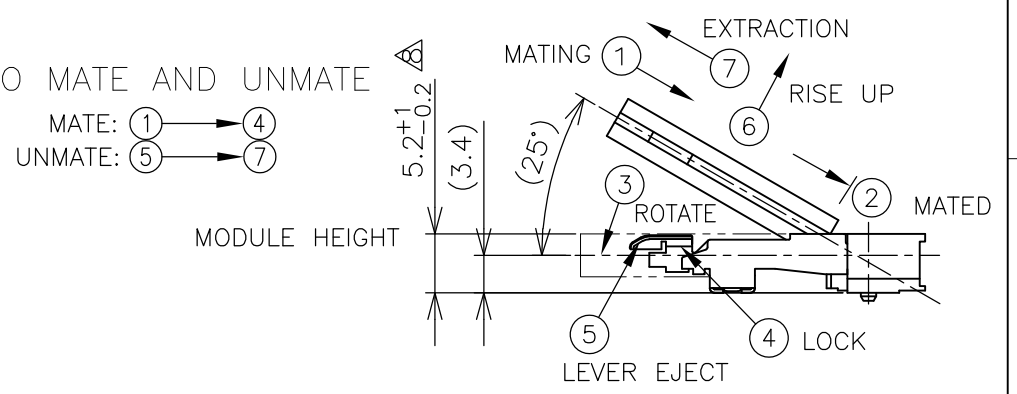
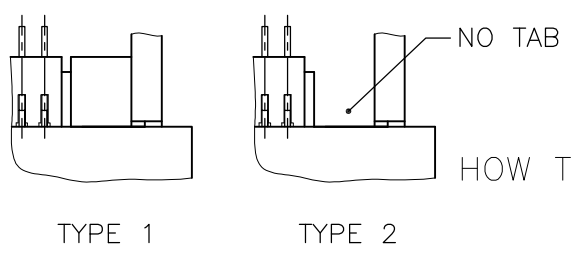
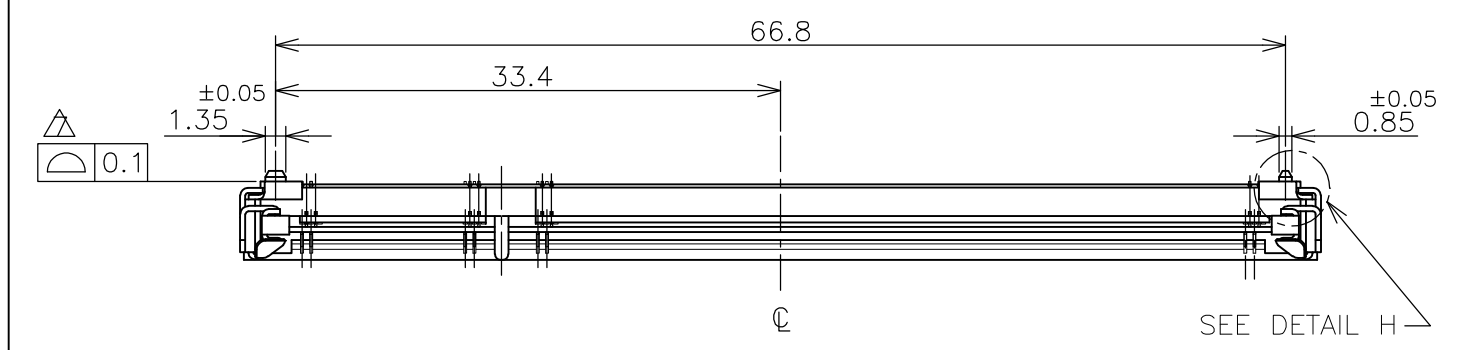
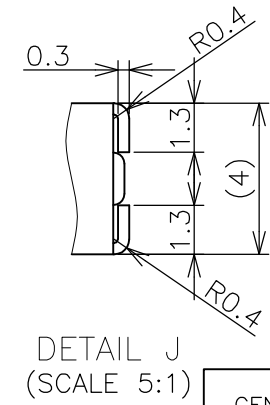
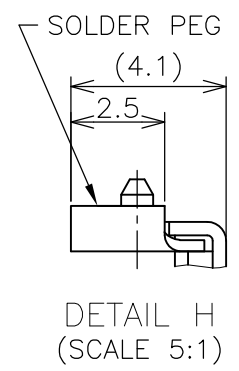
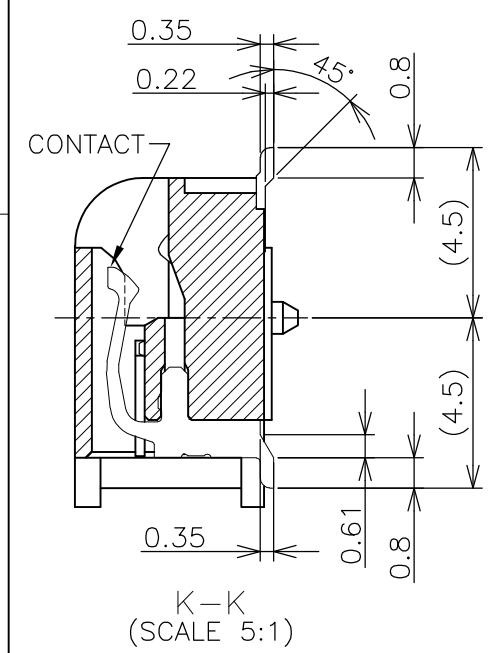

GENERAL TOLERANCE
 10 ≥ : ±0.2
 30 ≥ > 10 : ±0.25
 100 ≥ > 30 : ±0.3
 ANGLES : ±3°

TYPE 2	AVAILABLE	—H—	1.8V (DDR2)	17.55	2.4	2.7	200	1717254-4	
TYPE 1	AVAILABLE	—H—	2.5V (DDR1)	18.45	1.5	1.8	200	1717254-1	
TAB TYPE	TOOLING STATUS	REMARK	POWER SUPPLY (TYPE)	D5	D4	D3	POS	PART NO.	
THIS DRAWING IS A CONTROLLED DOCUMENT.			DWN	16JUL10		TE Connectivity DDR1 & DDR2 SODIMM SOCKET 0.6mm PITCH 200POS STANDARD PROFILE STANDARD TYPE			
DIMENSIONS: MM			CHK	16JUL10					
TOLERANCES UNLESS OTHERWISE SPECIFIED:			APVD	16JUL10					
0 PLC ± 1 PLC ± 2 PLC ± 3 PLC ± 4 PLC ± ANGLES ± FINISH ±			NAME	S.YAO					
MATERIAL			PRODUCT SPEC	108-5701		SIZE	CAGE CODE	DRAWING NO	RESTRICTED TO
			APPLICATION SPEC			A3	00779	C-1717254	
			WEIGHT	4.7g		SCALE	2:1		SHEET
			CUSTOMER DRAWING			1 OF 4		REV	D2

THIS DRAWING IS UNPUBLISHED. RELEASED FOR PUBLICATION NOV ,2001.
 © COPYRIGHT 2001 By - ALL RIGHTS RESERVED.

LOC	DIST	REVISIONS			
P	LTR	DESCRIPTION	DATE	DWN	APVD
J		SEE SHEET 1	-	-	-

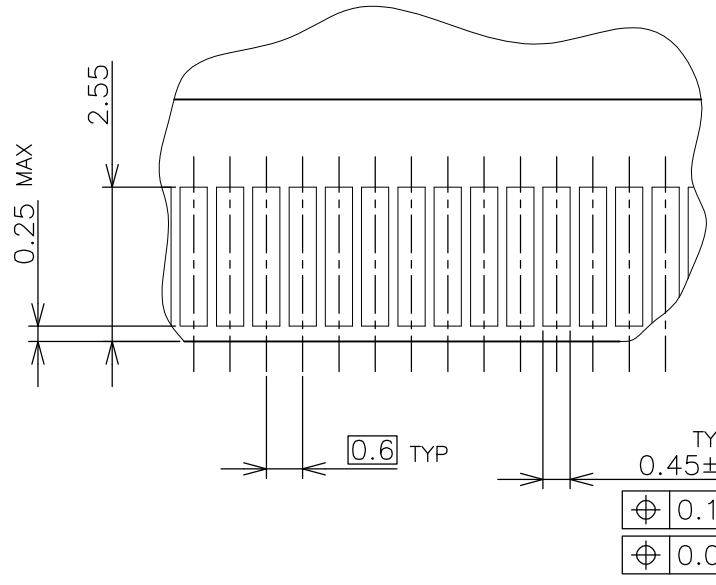
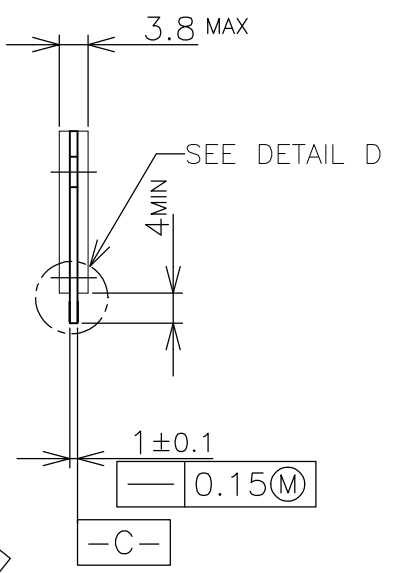
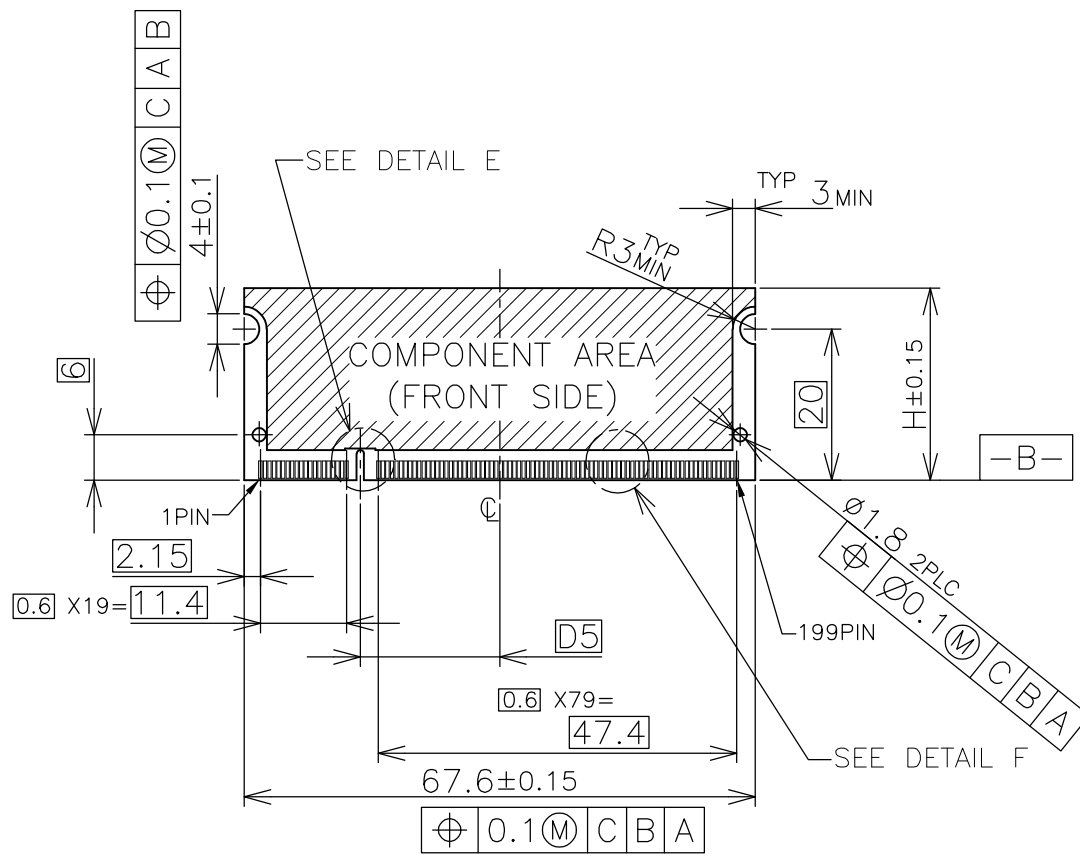

- (APPLIED TO SHEET 3)
1. TOLERANCES ON ALL DIMENSIONS ±0.15 UNLESS OTHERWISE SPECIFIED.
 2. P.C. BOARD THICKNESS APPLIES ACROSS TABS AND INCLUDES PLATING AND/OR METALIZATION.
 3. FINISH OF PAD : GOLD PLATING 0.00076 MIN. OVER Ni PLATING 0.002MIN.
- ▲ NO BURR
 ▲ CHAMFER 0.25 MAX x 45° IF EXIST.

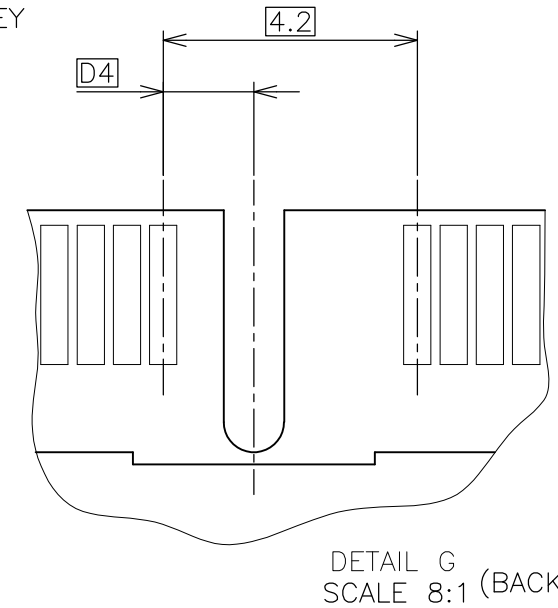
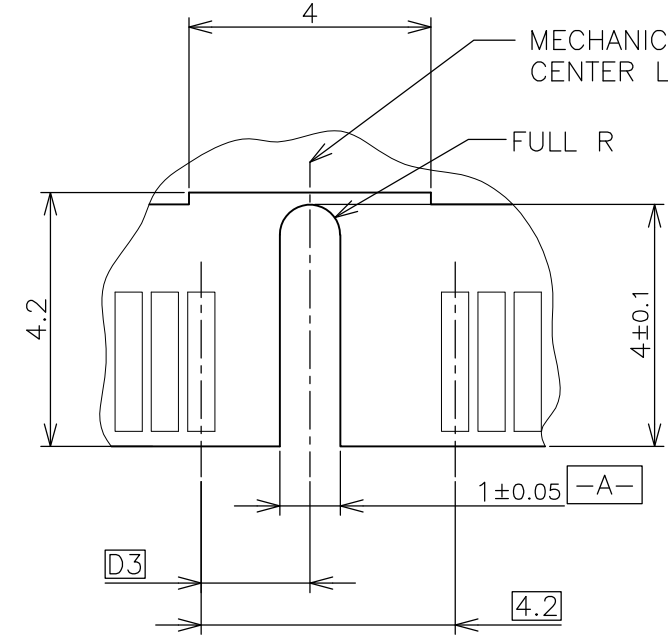
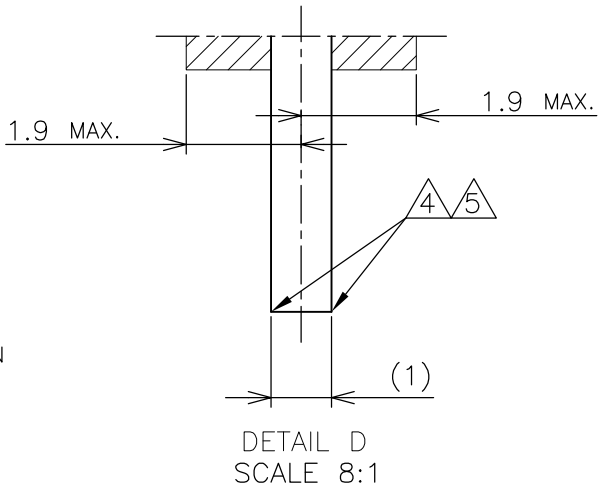
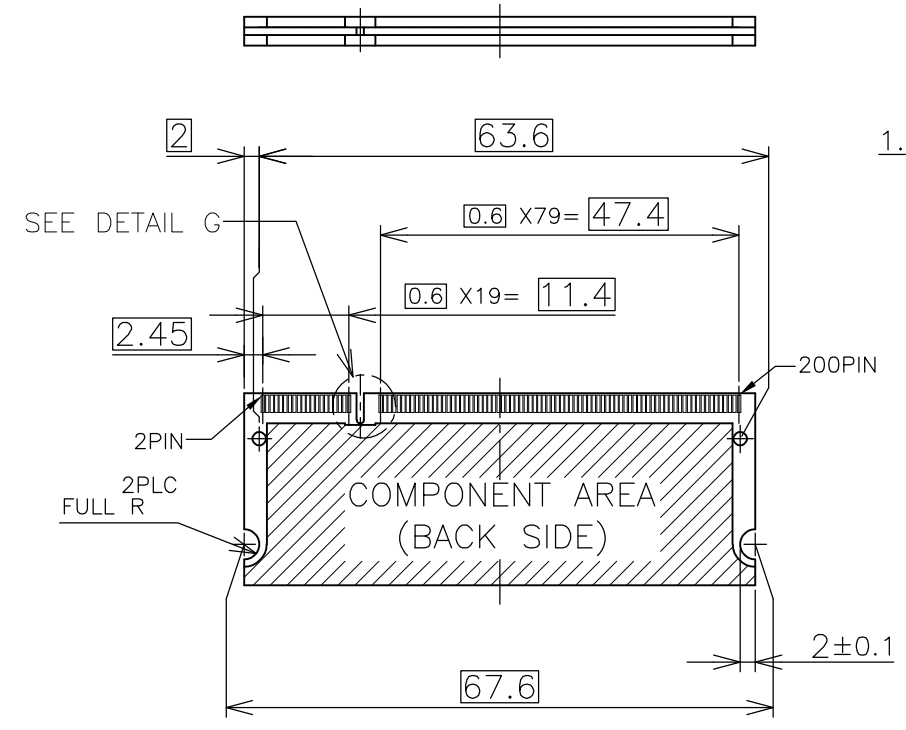

RECOMMENDED MATING P.C.B CONFIGURATION

31.75	1.8V	17.55	2.4	2.7
25.4	2.5V	18.45	1.5	1.8
H	POWER SUPPLY	D5	D4	D3

THIS DRAWING IS A CONTROLLED DOCUMENT.		DWN	TE Connectivity DDR1 & DDR2 SODIMM SOCKET 0.6mm PITCH 200POS STANDARD PROFILE STANDARD TYPE		
DIMENSIONS: MM		CHK			
TOLERANCES UNLESS OTHERWISE SPECIFIED:		APVD			
0 PLC ± 1 PLC ± 2 PLC ± 3 PLC ± 4 PLC ± ANGLES ± FINISH ±		PRODUCT SPEC			
MATERIAL		APVD	NAME	RESTRICTED TO	
		PRODUCT SPEC	SIZE	CAGE CODE	DRAWING NO
		APPLICATION SPEC	A3 00779 C-1717254		
		WEIGHT	SCALE	SHEET	REV
		CUSTOMER DRAWING	2:1	3 OF 4	D2

THIS DRAWING IS UNPUBLISHED. RELEASED FOR PUBLICATION NOV , 2001.
 © COPYRIGHT 2001 By - ALL RIGHTS RESERVED.

LOC	DIST	REVISIONS					
		P	LTR	DESCRIPTION	DATE	DWN	APVD
J		-	-	SEE SHEET 1	-	-	-

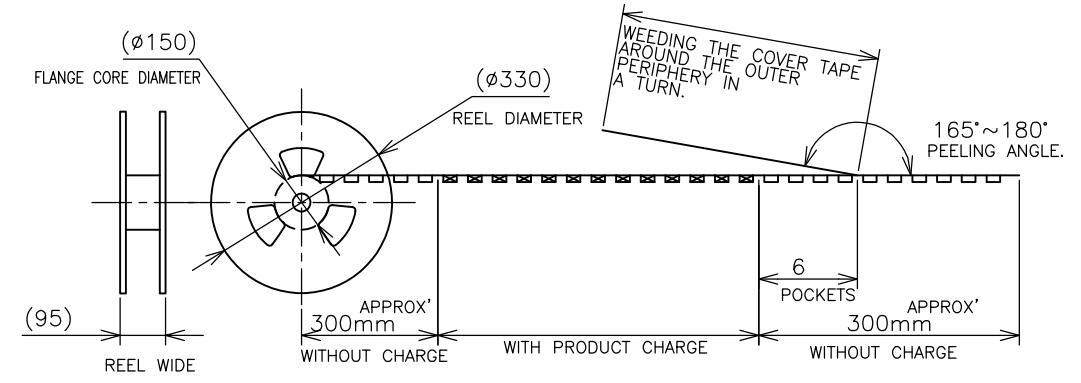
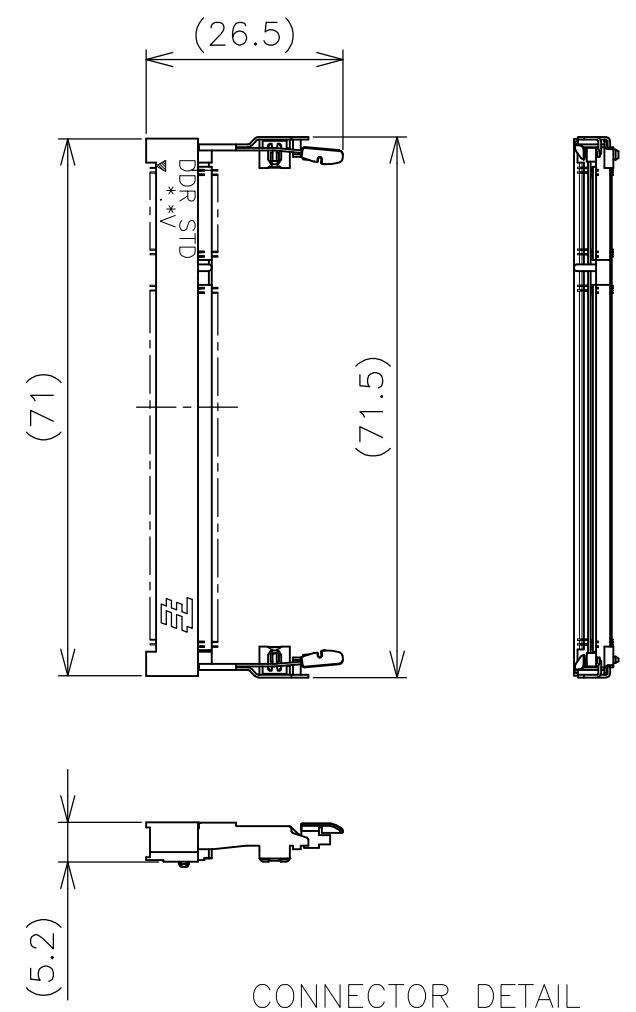
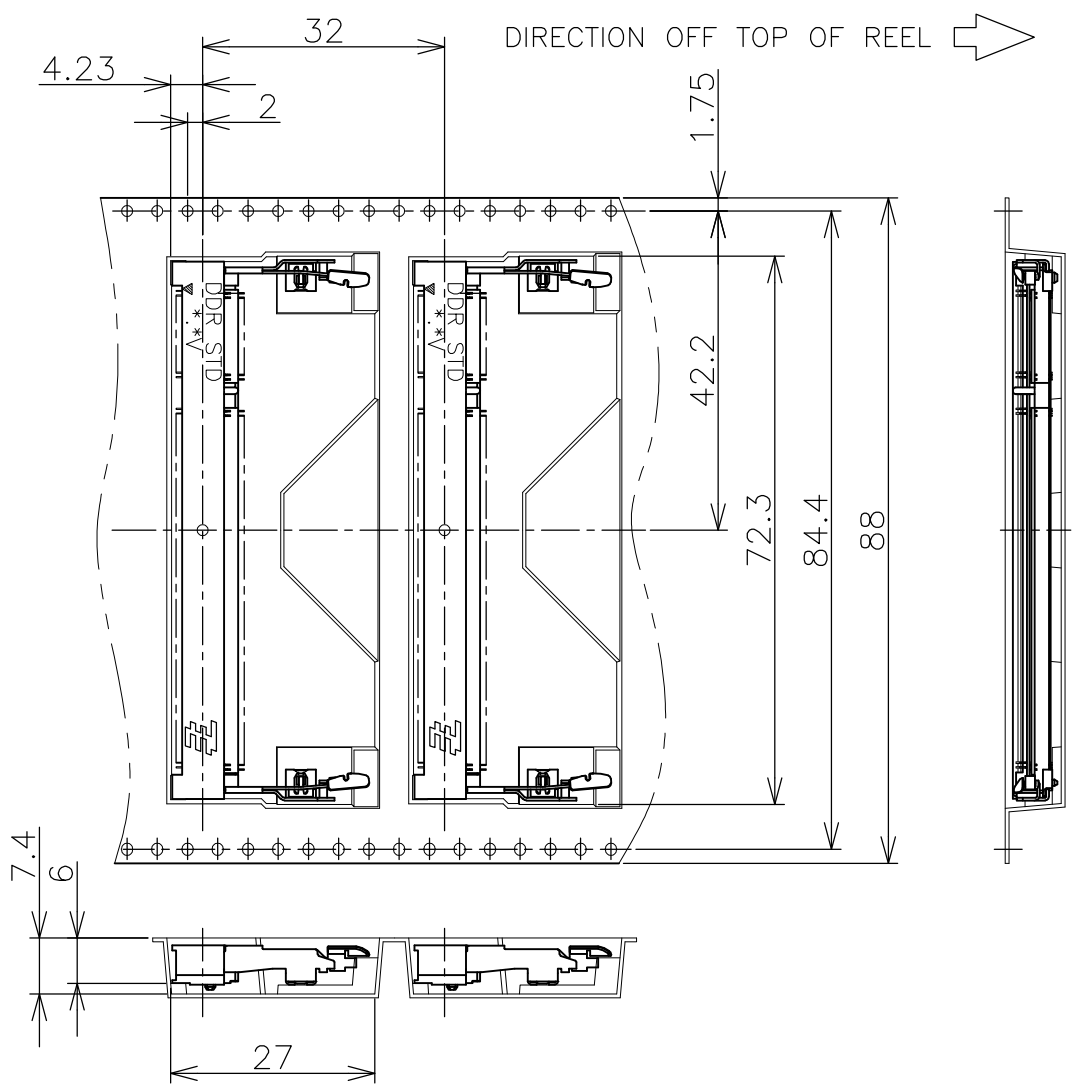

1.8V (DDR2)	150EA/REEL	1717254-4
2.5V (DDR1)	150EA/REEL	1717254-1
POWER SUPPLY (TYPE)	QTY	P/N

THIS DRAWING IS A CONTROLLED DOCUMENT.		DWN	TE Connectivity NAME DDR1 & DDR2 SODIMM SOCKET 0.6mm PITCH 200POS STANDARD PROFILE STANDARD TYPE			
DIMENSIONS: MM		CHK				
TOLERANCES UNLESS OTHERWISE SPECIFIED: 0 PLC ± 1 PLC ± 2 PLC ± 3 PLC ± 4 PLC ± ANGLES ± FINISH ±		APVD				
MATERIAL		PRODUCT SPEC				
		APPLICATION SPEC	SIZE	CAGE CODE	DRAWING NO	RESTRICTED TO
		WEIGHT	A3	00779	C-1717254	-
CUSTOMER DRAWING			SCALE	SHEET	REV	
			1:1	4 OF 4	D2	