

THIS DRAWING IS UNPUBLISHED. RELEASED FOR PUBLICATION
 © COPYRIGHT - By - ALL RIGHTS RESERVED.

REVISIONS					
P	LTR	DESCRIPTION	DATE	DWN	APVD
H		REVISED PER ECO-18-009360	15JUN2018	AP	DG

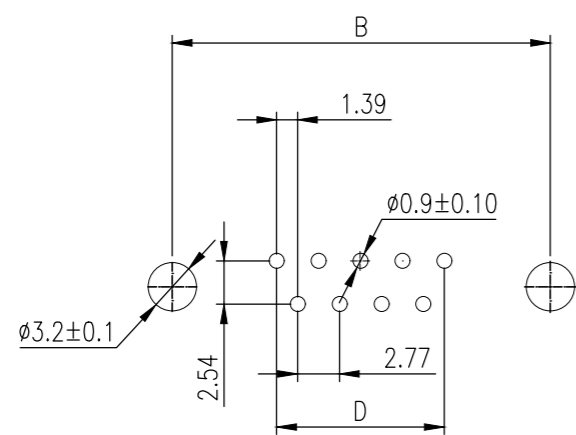
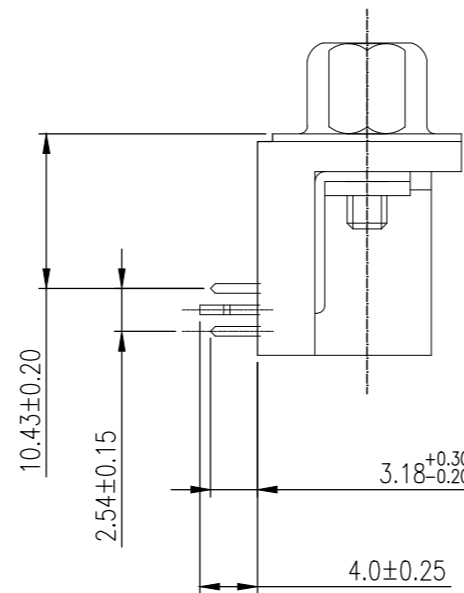
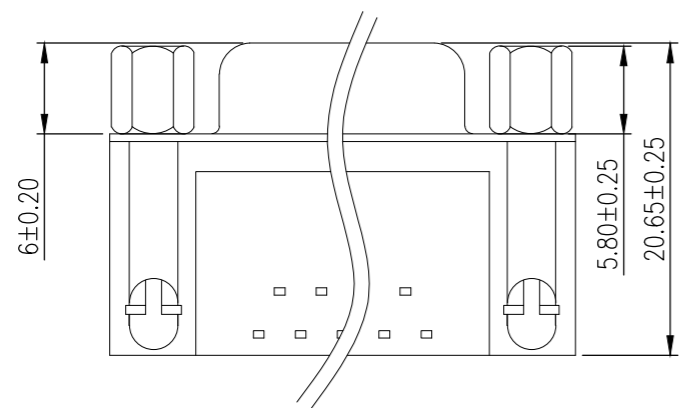
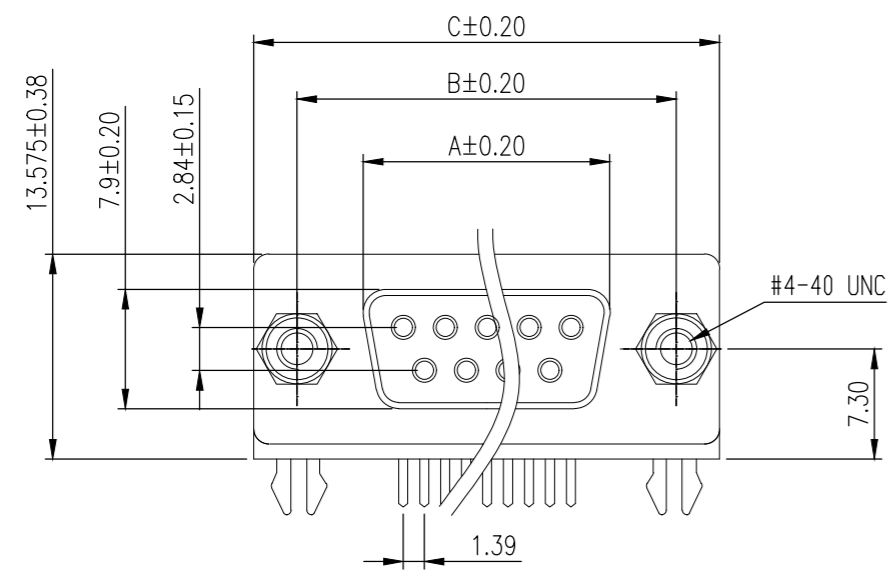

P.C.B LAYOUT

PRAT NUMBER	No. of Contact	A ±0.20	B ±0.20	C ±0.20	D
2301846-1	25	38.33	47.04	53.04	33.24

NOTE:

- MATERIAL:
 HOUSING: PBT WITH 20% GF UL 94 V-0, BLACK COLOR
 CONTACTS: PHOSPHOR BRONZE.
 SHELL: STEEL
 GROUNDING BRACKET: BRASS
 RIVETED INSERT: BRASS
 SCREWLOCK: BRASS
- FINISH:
 CONTACTS: 0.36 μm [15 μ"] GOLD IN CONTACT AREA.
 2.54 μm [100 μ"] MATTE TIN ON SOLDER TAILS
 1.27 μm [50 μ"] NICKEL UNDERPLATE OVERALL
 SHELL: 2.54 μm [100 μ"] NICKEL
 RIVET: 1.27 μm [50 μ"] NICKEL
 SCREWLOCK: 1.27 μm [50 μ"] NICKEL
 BOARDLOCK: 1.27 μm [50 μ"] MIN NICKEL UNDERPLATE.
 2.54 μm [100 μ"] MIN MATTE TIN PLATE.
- WAVE SOLDER CAPABLE TO 265°C PER TE TEST SPEC. 109-202, CONDITION B.

2301846

THIS DRAWING IS A CONTROLLED DOCUMENT.		DWN	AJITH PAI	07FEB2017	25W D SKT W B/L & 4-40 S/LOCK 15U" GOLD		2301846-1
DIMENSIONS: mm		CHK	DAN GORENC	07FEB2017	DESCRIPTION		TE PART NO
TOLERANCES UNLESS OTHERWISE SPECIFIED:		APVD		07FEB2017	NAME		
0 PLC ± -		PRODUCT SPEC		108-130013			
1 PLC ± 0.38		APPLICATION SPEC		-			
2 PLC ± 0.25		WEIGHT		0			
3 PLC ± 0.10		SCALE		3:1			
4 PLC ± -		SHEET		1 of 3			
ANGLES ± -		REV		H			
FINISH		CUSTOMER DRAWING		A2 00779 C=2301846			
MATERIAL		SCALE		3:1			
-		SHEET		1 of 3			
-		REV		H			
		DRAWING NO		25 WAY D-SUB SOCKET WITH BOARD LOCK			
		RESTRICTED TO		-			
		CAGE CODE		00779			
		DRAWING NO		C=2301846			

THIS DRAWING IS UNPUBLISHED. RELEASED FOR PUBLICATION
 © COPYRIGHT - By - ALL RIGHTS RESERVED.

REVISIONS				
P	LTR	DESCRIPTION	DATE	APVD
-	-	SEE SHEET 1	-	-

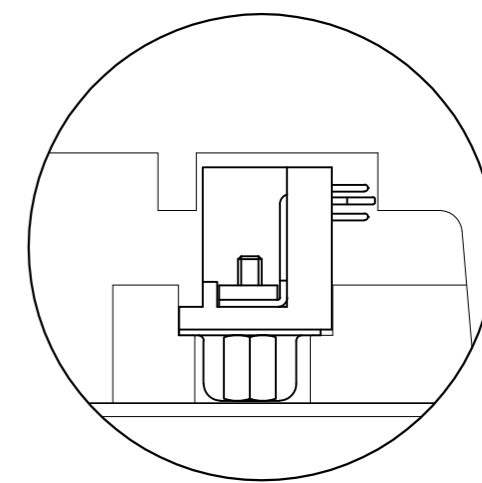
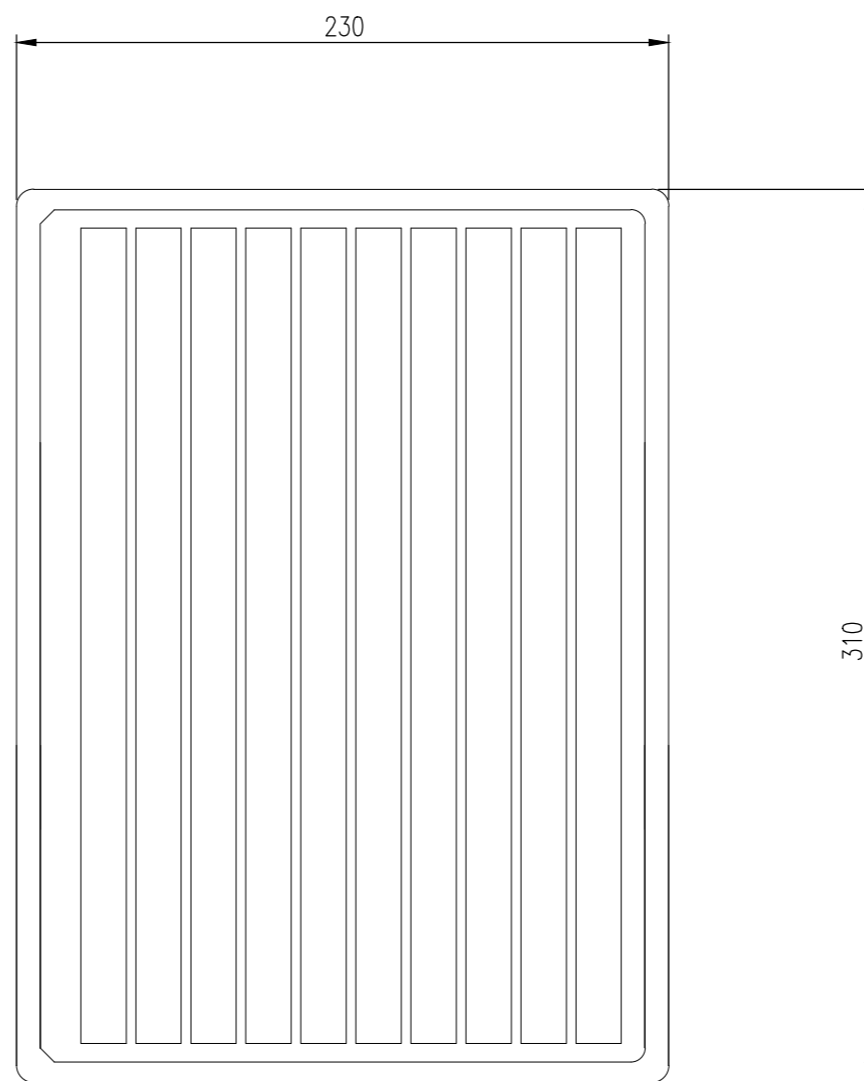
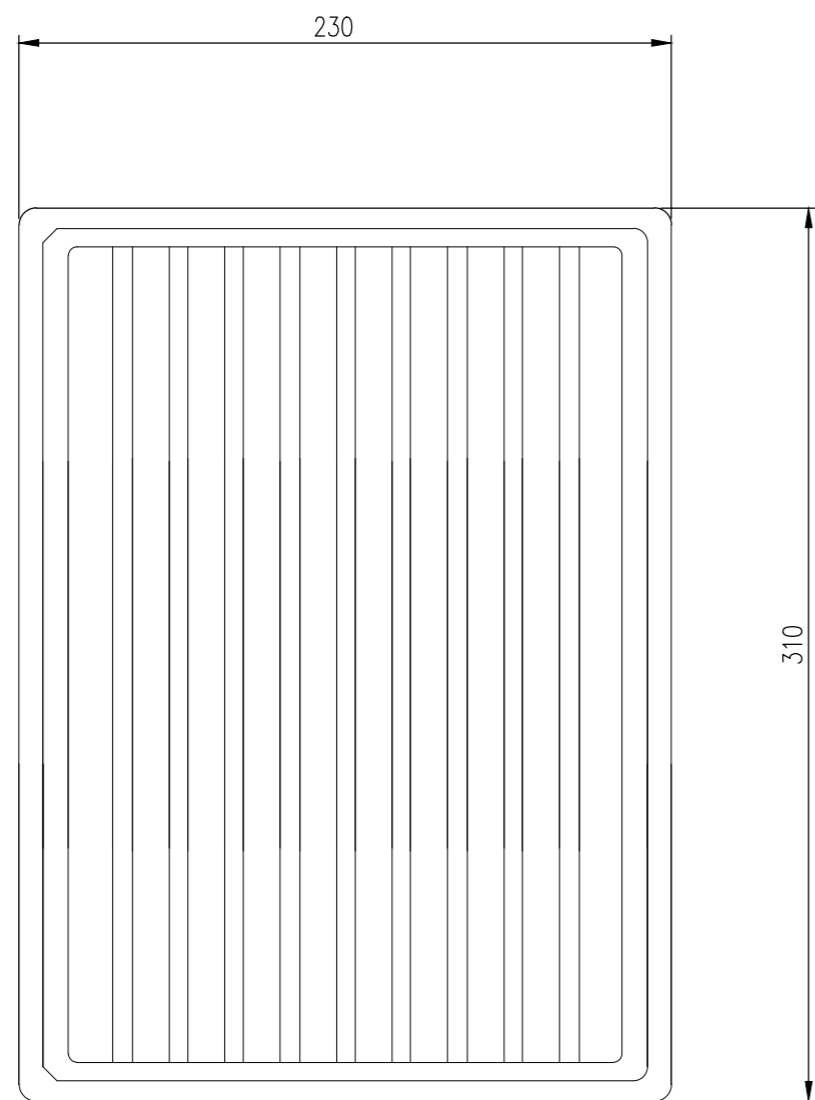
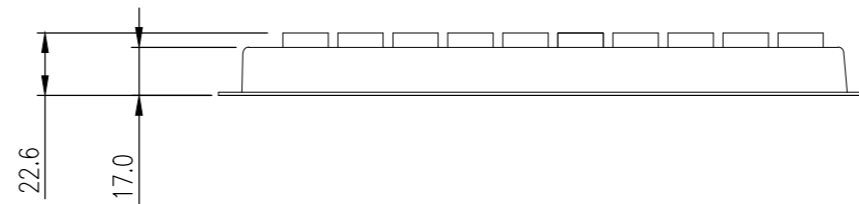
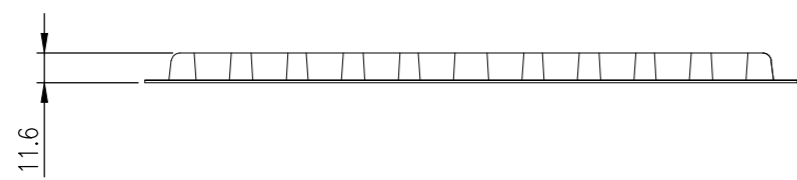

DETAIL A

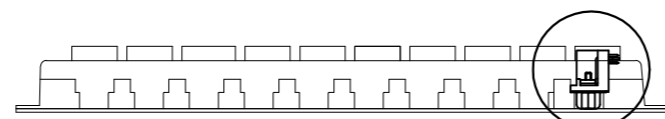

DETAIL A

THIS DRAWING IS A CONTROLLED DOCUMENT.		DWN AJITH PAI 07FEB2017					
DIMENSIONS: mm		CHK DAN GORENC 07FEB2017					
TOLERANCES UNLESS OTHERWISE SPECIFIED:		APVD - 07FEB2017	NAME 25 WAY D-SUB SOCKET WITH BOARD LOCK				
0 PLC ± - 1 PLC ± 0.38 2 PLC ± 0.25 3 PLC ± 0.10 4 PLC ± - ANGLES ± -		PRODUCT SPEC 108-130013	SIZE A2	CAGE CODE 00779	DRAWING NO C=2301846	RESTRICTED TO -	
MATERIAL -		FINISH -	WEIGHT 0	SCALE 3:1		SHEET 2 of 3	REV H
CUSTOMER DRAWING							

THIS DRAWING IS UNPUBLISHED. RELEASED FOR PUBLICATION
 © COPYRIGHT - By - ALL RIGHTS RESERVED.

REVISIONS					
P	LTR	DESCRIPTION	DATE	DWN	APVD
-	-	SEE SHEET 1	-	-	-

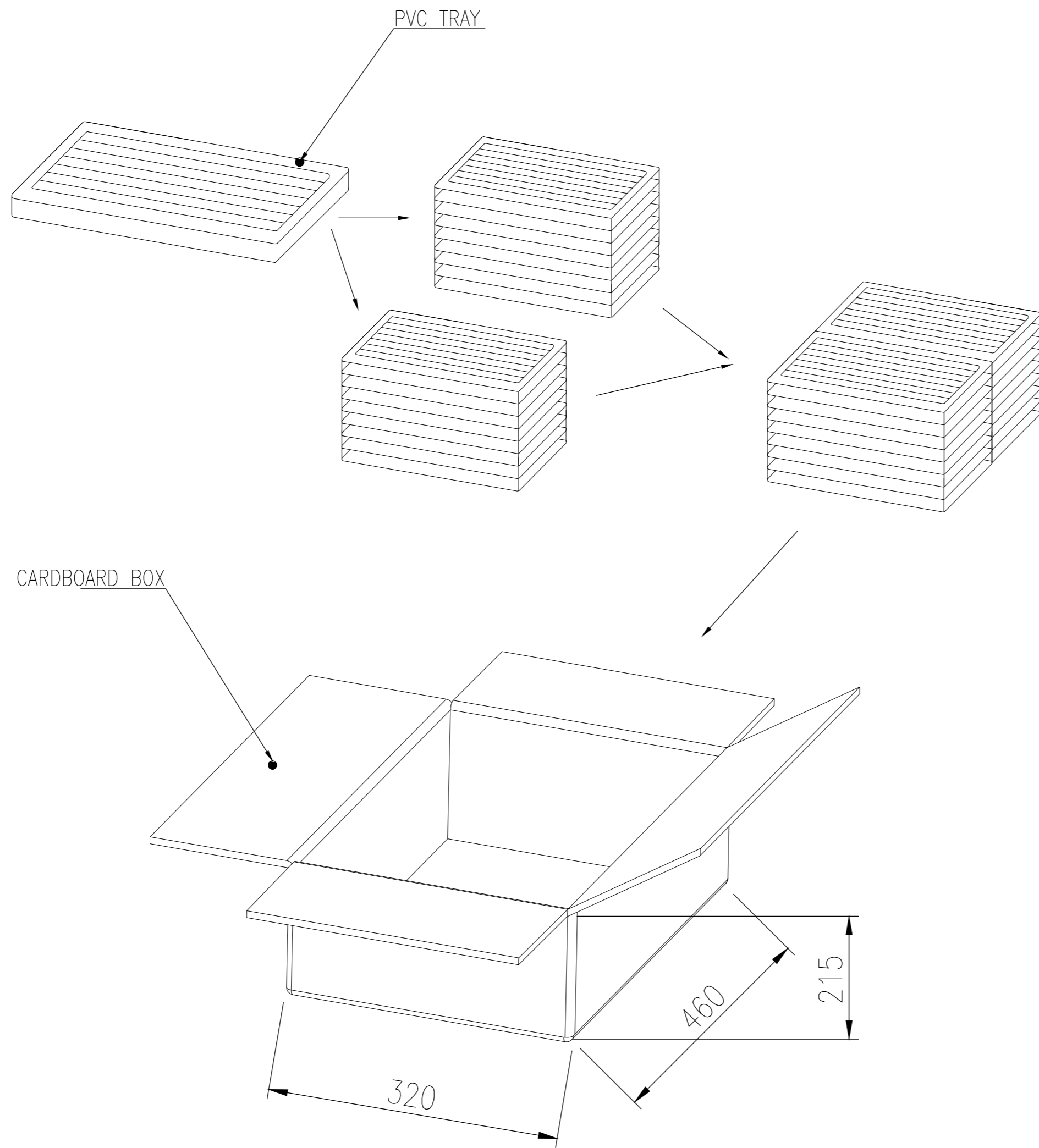

14.5	12.48	50	16	800	2301846-1
GROSS WEIGHT (Kg)	NET WEIGHT (Kg)	PCS/TRAY	TRAYS /CARTON	QUANTITY Pcs	PART NUMBER

THIS DRAWING IS A CONTROLLED DOCUMENT.		DWN AJITH PAI 07FEB2017			
DIMENSIONS: mm		CHK DAN GORENC 07FEB2017			
TOLERANCES UNLESS OTHERWISE SPECIFIED:		APVD - 07FEB2017	NAME 25 WAY D-SUB SOCKET WITH BOARD LOCK		
0 PLC ± -		PRODUCT SPEC 108-130013	SIZE A2	CAGE CODE 00779	DRAWING NO C=2301846
1 PLC ± 0.38		APPLICATION SPEC -	RESTRICTED TO -		
2 PLC ± 0.25		WEIGHT 0	SCALE 1:1	SHEET 3 of 3	REV H
3 PLC ± 0.10		CUSTOMER DRAWING			
4 PLC ± -					
ANGLES ± -					
MATERIAL -		FINISH -			

2301846