

# SPECIFICATIONS



**Model Number:** MT24R0X-E2  
**Part Number:** 19041196A

**Reversion:** 04  
 Feb 26, 2021

## Mechanical Drawing:

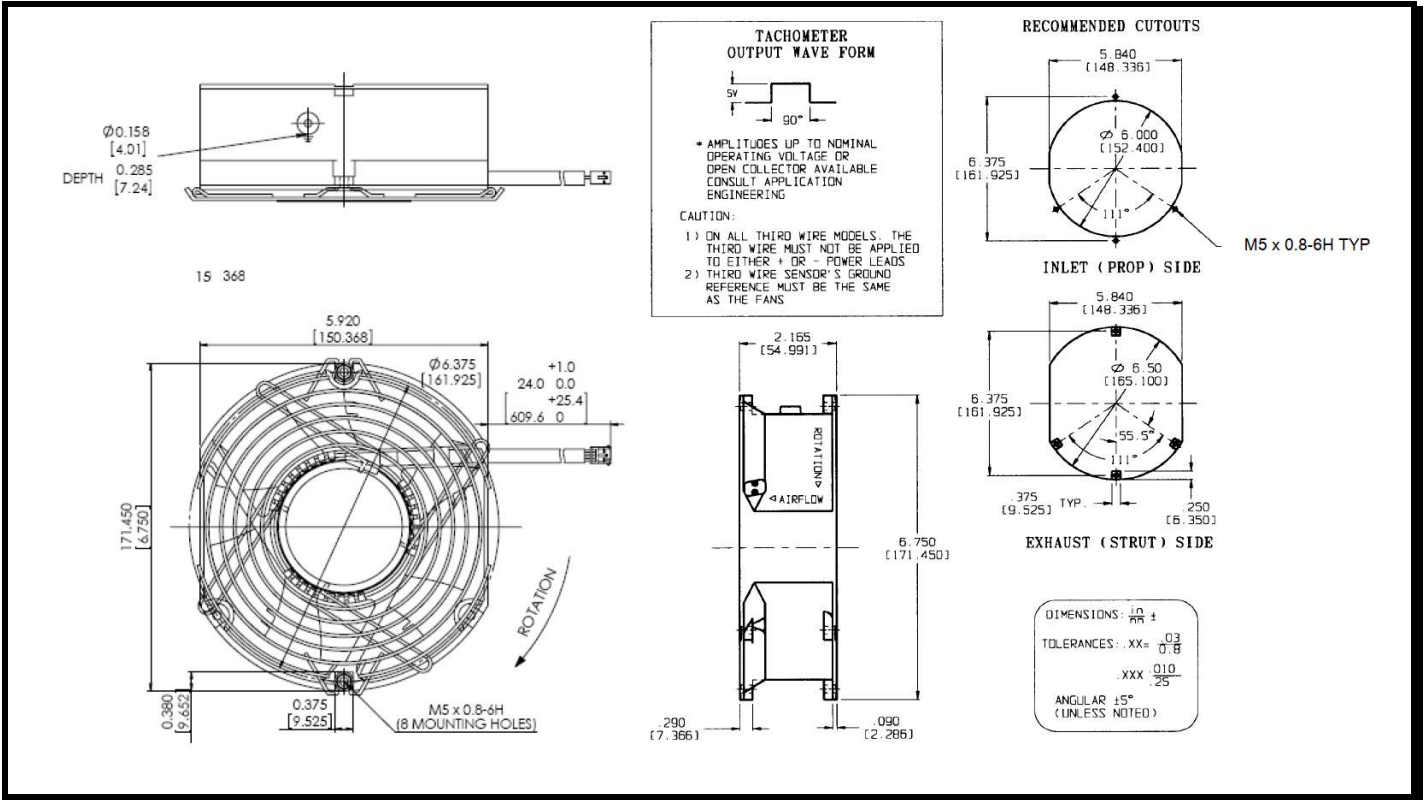

### Motor:

Nominal Voltage	= 24 vdc
Operating Voltage Range	= 12 - 28 vdc
Nominal Running Current	= 1.70 amps
Max. Locked Rotor Current	= 3.50 amps
Running Power	= 41.0 watts
Speed	= 4000 $\pm$ 10% RPM
Bearings	= Ball
Air Flow	= 345 CFM
Acoustic	= 60.6 dBA

### Construction:

Venturi:	Aluminum, Black.
Propeller:	Plastic, Black, UL94V-0

### Life Expectancy:

This fan is designed for continuous duty life of 90,000 hours at 40°C.

### Agency Approved:

UL, CUL, CE

### Additional Features:

Brushless DC Motor	
Electronic Locked Rotor Protected	
Polarity Protected	
Automatic Restart Capability	
Operating Temperature:	-10°C to 70°C
Storage Temperature:	-40°C to 85°C
Enviroshield:	Type 2
Programmable Speed Control	
M5 tapped mounting holes – all faces	
Finger Guard attached to strut. Side	

### Tachometer:

Output:	Open Collector
I <sub>c</sub> :	5 mA Typical
Isolated:	No
Pulses per Revolution:	2

### Termination:

24" Harness, fan edge/tip of connector, 22 AWG, UL 1007

Connector: Tyco 350780-1

Terminals: Tyco 350561-3

Wire Seal: Tyco 794274-1

Pin 1: Tachometer (Blue)

Pin 2: Negative: Fan Ground (Black)

Pin 3: Positive: Fan Power (Red)

Pin 4: Program Lead (Yellow)

### Program Speed Control

Control signal type: PWM

Control signal freq: 4 KHz

PWM amplitude: Insensitive, 3VDC – 28VDC

Speed control profile

Duty Cycle (%)	Speed (RPM) W/ Tolerance (%)
0	0
10	0
15	1000 ± 10%
20	2000 ± 10%
25	2000 ± 10%
50	2650 ± 10%
75	3300 ± 10%
80	3500 ± 10%
100	4000 ± 10%

### PO Curve

