

REVISONS		DATE	DWN	APVD
LOC	DIST	DESCRIPTION		
C		REV PER ECO-06-018048	05OCT06	PY DM

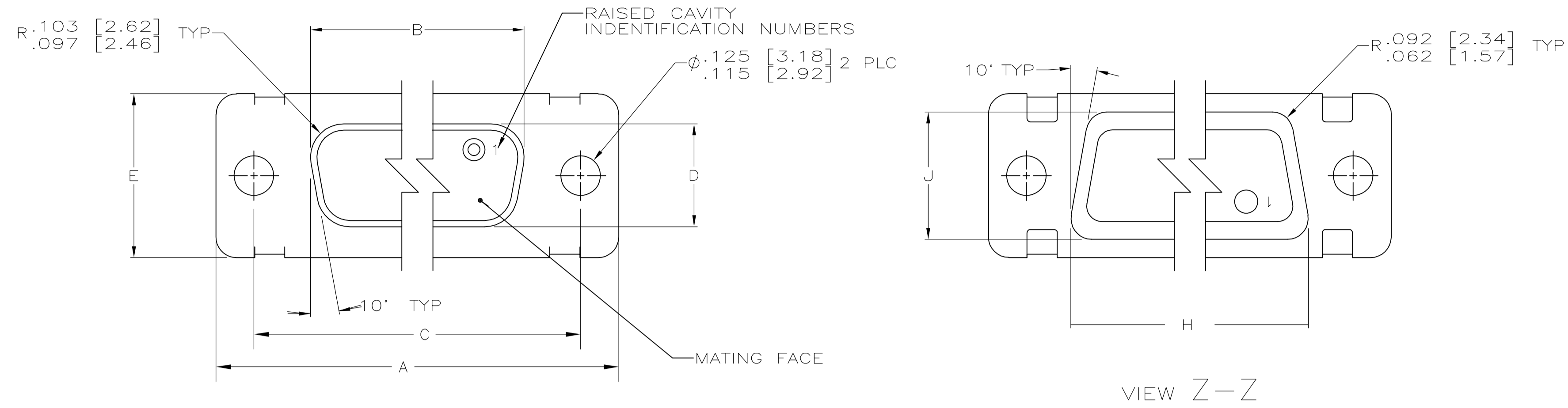

1. THIS CONNECTOR ASSEMBLY IS SUPPLIED WITH METAL CONTACT RETENTION CLIPS INSTALLED IN THE INSERT ASSEMBLY.
2. THIS CONNECTOR ASSEMBLY MEETS THE REQUIREMENTS OF MIL-C-24308 AND MATES WITH ANY PLUG CONNECTOR WITH SAME INSERT ARRANGEMENT.
3. THE PART NUMBER MARKED ON THE CONNECTOR DIFFERS FROM THE PART NUMBER ORDERED DUE TO THE MARKING REQUIREMENTS OF MIL-C-24308/6 (PART NUMBER MARKED ON CONNECTOR REPRESENTS CONNECTOR ASSEMBLY WITH CONTACTS). MARK WITH .047 [1.19]-.062 [1.57] HIGH CHARACTERS. FAR SIDE REFERS TO THE WIDE SIDE OF THE KEYSTONE. NEAR SIDE REFERS TO THE NARROW SIDE OF THE KEYSTONE. IF THE REAR SHELL IS TOO SMALL FOR THE ENTIRE MILITARY PART NUMBER, MARKING SHALL BE LOCATED AS FOLLOWS:
 - A. "M24308" ON FRONT SHELL, FAR SIDE.
 - B. SLASH SHEET AND DASH NUMBER ON REAR SHELL, FAR SIDE.
 - C. "AMP" AND DATE CODE ON FRONT SHELL, NEAR SIDE.
 - D. AMP PART NUMBER ON REAR SHELL, NEAR SIDE.
 IF THE FRONT SHELL IS TOO SMALL FOR "AMP", AMP PART NUMBER AND DATE CODE, THEN SPLIT AS FOLLOWS:
 - A. AMP PART NUMBER ON REAR SHELL, NEAR SIDE.
 - B. "AMP" AND DATE CODE ON FRONT SHELL, NEAR SIDE.
 - C. MILITARY PART NUMBER ON REAR SHELL, FAR SIDE.
4. POINT OF ELECTRICAL ENGAGEMENT - AS MEASURED WITH A .0295 [0.749] - .0305 [0.775] DIAMETER SQUARE ENDED TEST PIN. CONTACT NOT INCLUDED - SHOWN FOR DIMENSIONAL REFERENCE ONLY.

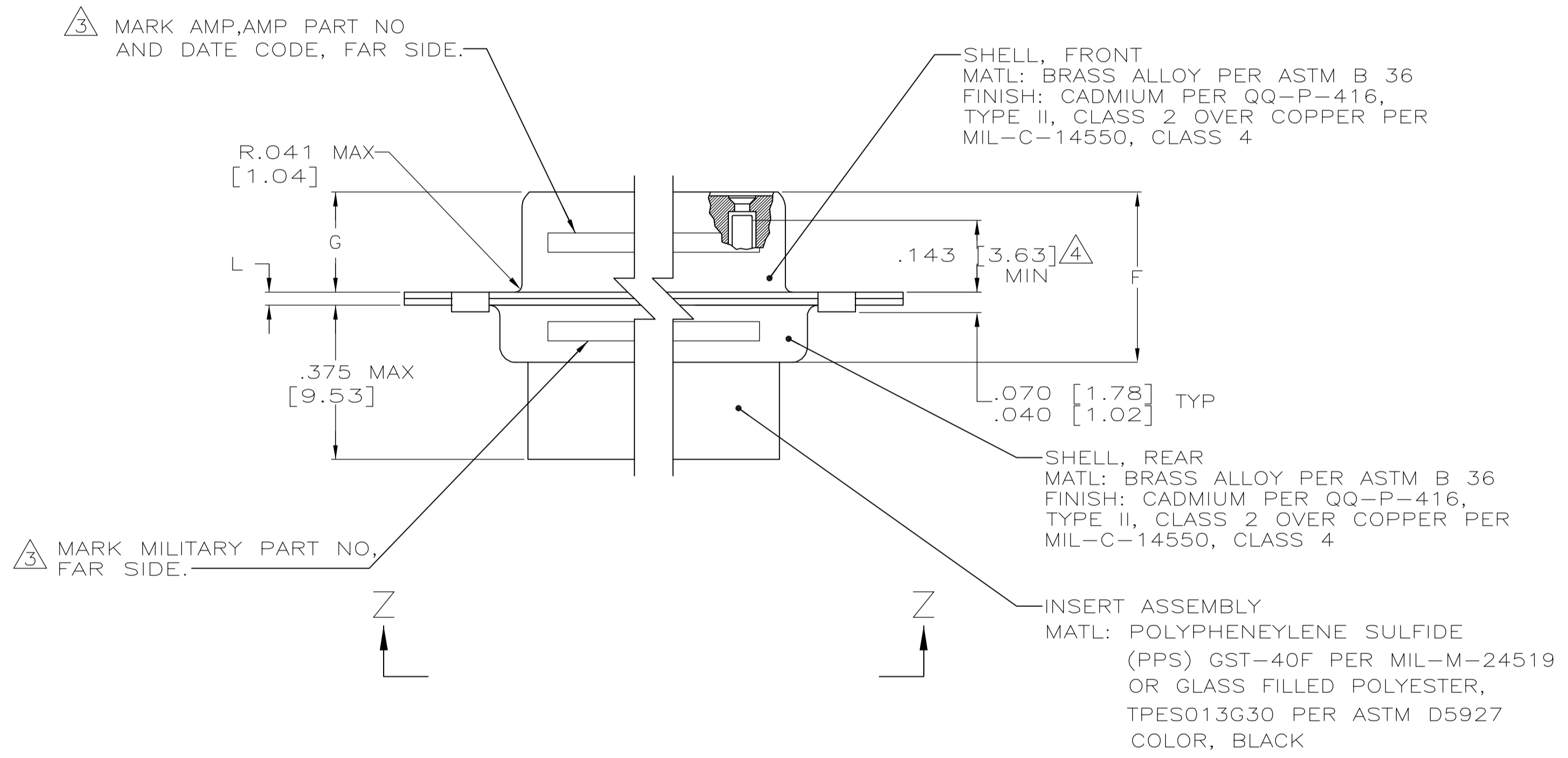

5. THIS CONNECTOR ASSEMBLY IS DESIGNED TO ACCEPT SIZE 22 CRIMP TYPE SOCKET CONTACT MILITARY PART NUMBER M39029/57-354 (AMP PART NUMBER 204351-1). FOR ALTERNATE CONTACT OPTIONS CONSULT AMP CATALOG 82069.
6. MAXIMUM WIRE INSULATION TO BE USED WITH THIS CONNECTOR ASSEMBLY IS .054 [1.37] DIAMETER.
7. FOR CONTACT CRIMPING INSTRUCTION SHEET REFER TO AMP IS 408-7516. FOR CONTACT INSTALLATION AND REMOVAL INSTRUCTION SHEET REFER TO AMP IS 408-7508.
8. PART NUMBER FOR ORDERING.
9. DIMENSIONS AND TOLERANCES PER ANSI Y14.5M-1982.
10. THIS DRAWING SHALL BE INTERPRETED IN ACCORDANCE WITH APPLICABLE STANDARDS LISTED IN MIL-STD-100.

.049 [1.24] .029 [0.74]	.544 [13.82] .524 [13.31]	2.188 [55.58]	.248 [6.30]	.439 [11.15]	.620 [15.75] .590 [14.99]	.428 [10.87] .418 [10.62]	2.411 [61.24]	2.069 [52.55]	2.650 [67.31]	MS18277-2	78	5	M24308/6-290F	M24308/6-15F	593041-5	593048-5
		2.282 [57.96] 2.262 [57.45]					2.401 [60.99]	2.059 [52.30]	2.620 [66.55]							
.040 [1.02] .020 [0.51]	.432 [10.97] .412 [10.46]	1.635 [41.53]	.238 [6.05]	.419 [10.64]	.509 [12.93] .479 [12.17]	.316 [8.03] .306 [7.77]	2.505 [63.63]	2.164 [54.97]	2.744 [69.70]	MS18276-2	62	4	M24308/6-289F	M24308/6-14F	593041-4	593048-4
		2.262 [57.45]					2.495 [63.37]	2.154 [54.71]	2.714 [68.94]							
.040 [1.02] .020 [0.51]	.432 [10.97] .412 [10.46]	1.093 [27.76]	.238 [6.05]	.419 [10.64]	.509 [12.93] .479 [12.17]	.316 [8.03] .306 [7.77]	1.857 [47.17]	1.516 [38.51]	2.103 [53.42]	MS18275-2	44	3	M24308/6-288F	M24308/6-13F	593041-3	593048-3
		1.073 [27.25]					1.847 [46.91]	1.506 [38.25]	2.073 [52.65]							
.040 [1.02] .020 [0.51]	.432 [10.97] .412 [10.46]	.769 [19.53] .749 [19.02]	.238 [6.05]	.419 [10.64]	.509 [12.93] .479 [12.17]	.316 [8.03] .306 [7.77]	1.317 [33.45]	.976 [24.79]	1.556 [39.52]	MS18274-2	26	2	M24308/6-287F	M24308/6-12F	593041-2	593048-2
		1.093 [27.76]					1.307 [33.20]	.966 [24.54]	1.526 [38.76]							
.040 [1.02] .020 [0.51]	.432 [10.97] .412 [10.46]	.769 [19.53] .749 [19.02]	.238 [6.05]	.419 [10.64]	.509 [12.93] .479 [12.17]	.316 [8.03] .306 [7.77]	1.989 [50.51]	.648 [16.46]	1.228 [31.19]	MS18273-2	15	1	M24308/6-286F	M24308/6-11F	593041-1	593048-1
		1.093 [27.76]					1.307 [33.20]	.966 [24.54]	1.198 [30.43]							
L	J	H	G	F	E	D	C	B	A	INSERT ARRANGEMENT	NO OF POS	SHELL SIZE	PACKAGE MILITARY P/N	MILITARY P/N ON CONNECTOR	AMP P/N ON CONNECTOR	PART NUMBER

THIS DRAWING IS A CONTROLLED DOCUMENT.

DIMENSIONS: INCHES	TOLERANCES UNLESS OTHERWISE SPECIFIED:	DWN: AJ GRAFF 11-18-92	APVD: B. GILLMAN 11-24-92	NAME: F. KINSEY 11-24-92	PRODUCT SPEC
0 PLC ± -	1 PLC ± -	2 PLC ± -	3 PLC ± .005 [0.13]	4 PLC ± -	ANGLES ± -
MATERIAL: SEE CALLOUTS	FINISH: SEE CALLOUTS	WEIGHT: -	SIZE: A1	DWG CODE: 00779	DRAWING NO: 593048
CUSTOMER DRAWING			SCALE: 4:1	SHEET: 1 OF 1	REV: C

tyco Electronics Tyco Electronics Corporation
 Harrisburg, PA 17105-3608

AMPLIMITE NONMAGNETIC RCPT ASSY WITHOUT SIZE 22 CRIMP SOCKET CONTACTS, SERIES 90 SHELL SIZES 1 THRU 5