

TLP116A

Plasma Display Panels (PDPs)
High-Speed Interface
Factory Automation (FA)

The Toshiba TLP116A mini-flat coupler is a small-outline coupler suitable for surface-mount assembly. The TLP116A consists of a GaAlAs light-emitting diode and an integrated high-gain, high-speed photodetector. This unit is housed in the 6-pin SO package and guarantees a creepage distance of $\geq 5.0\text{mm}$, a clearance of $\geq 5.0\text{mm}$ and an insulation thickness of $\geq 0.4\text{mm}$. Therefore, the TLP116A meets the reinforced insulation class requirements of international safety standards.

- Inverter logic (totem-pole output)
- SO6 package
- Guaranteed performance over: -40 to 100°C
- Power supply voltage: 4.5 to 5.5V
- Input thresholds current: $I_{FHL} = 5\text{ mA}$ (max)
- Propagation delay time (tpHL / tpLH): 60 ns (max)
- Switching speed: 20 MBd (typ.)
- Common-mode transient immunity: 10 kV/ μs
- Isolation voltage: 3750 Vrms
- UL approval: UL1577, File No.E67349 Under application
- cUL approved :CSA Component Acceptance Service
No. 5A, File No.E67349
- CQC approved:GB4943.1,GB8898 Japan Factory
 仅适用于海拔 2000m 以下地区安全使用
- Option (V4) VDE approved : DIN EN60747-5-5 ,EN60065,EN60950-1 (Note1)
EN62368-1(Pending) (Note1)

**Note 1 : When a EN60747-5-5 approved type is needed,
please designate "Option(V4)"**

Truth Table

Input	LED	Tr1	Tr2	Output
H	ON	OFF	ON	L
L	OFF	ON	OFF	H

Construction Mechanical Rating

Creepage Distance: 5.0mm (min)
Clearance: 5.0mm (min)
Insulation Thickness: 0.4mm (min)

Unit: mm

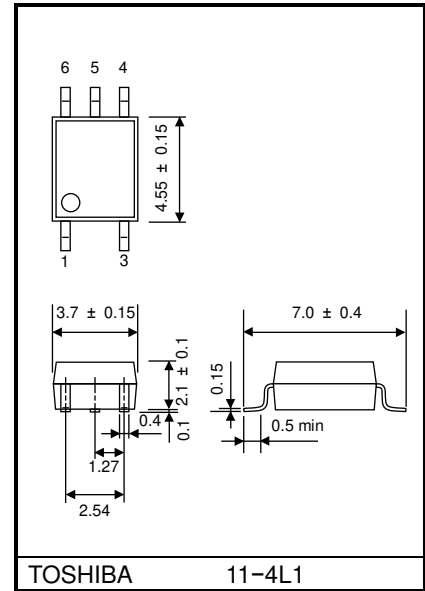

Weight: 0.08 g (typ.)

Pin Configuration (Top View)

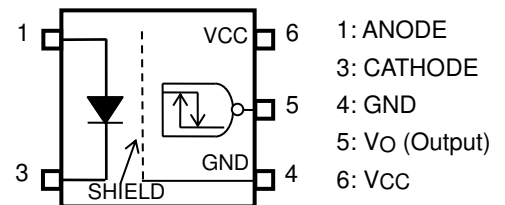

Start of commercial production
2008-07

Absolute Maximum Ratings (Ta=25°C)

Characteristic		Symbol	Rating	Unit
LED	Forward current	I_F	20	mA
	Forward current derating (Ta ≥ 85°C)	$\Delta I_F / ^\circ\text{C}$	-0.5	mA/°C
	Peak transient forward current (Note 1)	I_{FPT}	1	A
	Reverse voltage	V_R	5	V
	Input power dissipation	PD	40	mW
	Input power dissipation derating (Ta ≥ 85°C)	$\Delta PD / ^\circ\text{C}$	-1.0	mW/°C
DETECTOR	Output current	I_O	10	mA
	Output current derating (Ta ≥ 85°C)	$\Delta I_O / ^\circ\text{C}$	-0.25	mA/°C
	Output voltage	V_O	6	V
	Supply voltage	V_{CC}	6	V
	Output power dissipation	P_O	40	mW
Operating temperature range		T_{opr}	-40 to 100	°C
Storage temperature range		T_{stg}	-55 to 125	°C
Lead solder temperature(10 s)		T_{sol}	260	°C
Isolation voltage (AC,60 s, R.H. ≤ 60%) (Note 2)		BVs	3750	V_{rms}

Note: Using continuously under heavy loads (e.g. the application of high temperature/current/voltage and the significant change in temperature, etc.) may cause this product to decrease in the reliability significantly even if the operating conditions (i.e. operating temperature/current/voltage, etc.) are within the absolute maximum ratings and the operating ranges. Please design the appropriate reliability upon reviewing the Toshiba Semiconductor Reliability Handbook ("Handling Precautions"/"Derating Concept and Methods") and individual reliability data (i.e. reliability test report and estimated failure rate, etc).

Note 1 : Pulse width $PW \leq 1\mu\text{s}$, 300 pps.

Note 2 :This device is regarded as a two terminal device : pins 1 and 3 are shorted together, as are pins 4,5 and 6.

Recommended Operating Conditions

Characteristic	Symbol	Min	Typ.	Max	Unit
Input current ON	$I_{F(ON)}$	8	—	18	mA
Input voltage , OFF	$V_{F(OFF)}$	0	—	0.8	V
Supply voltage	V_{CC}	4.5	5.0	5.5	V
Operating temperature	T_{opr}	-40	—	100	°C

Note: Recommended operating conditions are given as a design guideline to obtain expected performance of the device. Additionally, each item is an independent guideline respectively. In developing designs using this product, please confirm specified characteristics shown in this document.

Note: The detector of this product requires a power supply voltage (V_{CC}) of 4.5 V or higher for stable operation. If the V_{CC} is lower than this value, an ICC may increase, or an output may be unstable. Be sure to use the product after checking the supply current, and the operation of a power-on/-off.

Electrical Characteristics

(Unless otherwise specified, Ta=-40 to 100°C, VCC=4.5 to 5.5 V)

Characteristic	Symbol	Test Circuit	Conditions	Min	Typ.	Max	Unit
Input forward voltage	V _F	—	I _F = 10 mA, Ta = 25°C	1.45	1.58	1.85	V
Temperature coefficient of forward voltage	ΔV _F / ΔTa	—	I _F = 10 mA	—	-2.0	—	mV/°C
Input reverse current	I _R	—	V _R =5 V, Ta = 25°C	—	—	10	μA
Capacitance between Input terminals	C _T	—	V _F = 0 V, f = 1 MHz, Ta = 25°C	—	60	—	pF
Logic low output voltage	V _{OL}	1	I _{OL} = 1.6 mA, I _F = 12 mA, V _{CC} = 5 V	—	—	0.4	V
Logic high output voltage	V _{OH}	2	I _{OH} = -0.02 mA, V _F = 1.05 V, V _{CC} = 5 V	4.0	—	—	V
Logic low supply current	I _{CCL}	3	I _F = 12 mA	—	—	5.0	mA
Logic high supply current	I _{CCH}	4	V _F = 0 V	—	—	5.0	mA
Input current logic low output	I _{FHL}	—	I _O = 1.6 mA, V _O < 0.4 V	—	—	5	mA
Input voltage logic high output	V _{FLH}	—	I _O = -0.02 mA, V _O > 4.0 V	0.8	—	—	V

*All typical values are at Ta=25°C, VCC=5 V, I_F(ON)=12 mA unless otherwise specified

Isolation Characteristics (Ta = 25°C)

Characteristic	Symbol	Test Conditions	Min	Typ.	Max	Unit
Capacitance input to output	C _S	V _s = 0 V, f = 1 MHz (Note 1)	—	0.8	—	pF
Isolation resistance	R _S	R.H. ≤ 60%, V _S = 500 V (Note 1)	1×10 ¹²	10 ¹⁴	—	Ω
Isolation voltage	B _V _S	AC, 60 s	3750	—	—	V _{rms}
		AC, 1 s, in oil	—	10000	—	
		DC, 60 s, in oil	—	10000	—	V _{dc}

Note 1:A ceramic capacitor(0.1 μF) should be connected from pin 6 to pin 4 to stabilize the operation of the high gain linear amplifier. Failure to provide the bypass may impair the switching property.
The total lead length between capacitor and coupler should not exceed 1 cm.

Switching Characteristics

(Unless otherwise specified, $T_a = -40$ to 100°C , $V_{CC} = 4.5$ to 5.5 V)

Characteristic	Symbol	Test Circuit	Conditions	Min	Typ.	Max	Unit
Propagation delay time to logic high output	t_{pHL}	5	$I_F = 0 \rightarrow 12$ mA	—	—	60	ns
Propagation delay time to logic low output	t_{pLH}		$I_F = 12 \rightarrow 0$ mA				
Propagation delay time to logic high output	t_{pHL}	6	$V_{IN} = 0 \rightarrow 5$ V ($I_F = 0 \rightarrow 8$ mA)	—	—	60	ns
Propagation delay time to logic low output	t_{pLH}		$V_{IN} = 5 \rightarrow 0$ V ($I_F = 8 \rightarrow 0$ mA)				
Switching time dispersion between ON and OFF	$ t_{pHL} - t_{pLH} $	5	$I_F = 12$ mA, $R_{IN} = 100 \Omega$, $C_L = \approx 15$ pF (Note 1)	—	—	30	ns
Output fall time(90-10%)	t_f		$I_F = 0 \rightarrow 12$ mA				
Output rise time(10-90%)	t_r		$I_F = 12 \rightarrow 0$ mA				
Common mode transient immunity at high Level output	CM_H	7	$V_{CM} = 1000$ Vp-p, $I_F = 0$ mA, $V_o(\text{Min}) = 4$ V, $T_a = 25^\circ\text{C}$	10000	—	—	V/ μs
Common mode transient immunity at low level output	CM_L		$V_{CM} = 1000$ Vp-p, $I_F = 12$ mA, $V_o(\text{Max}) = 0.4$ V, $T_a = 25^\circ\text{C}$				

*All typical values are at $T_a = 25^\circ\text{C}$

Note 1: C_L is approximately 15 pF which includes probe and Jig/stray wiring capacitance.

TEST CIRCUIT 1: V_{OL}

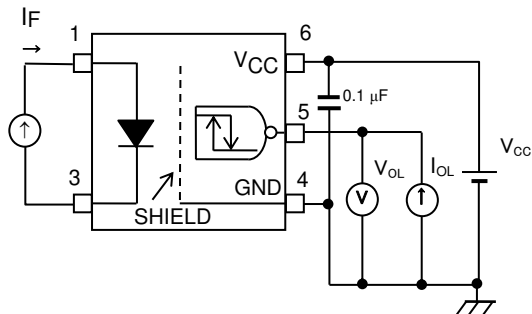

TEST CIRCUIT 2: V_{OH}

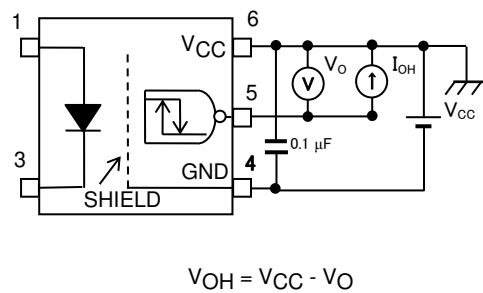

TEST CIRCUIT 3: I_{CCL}

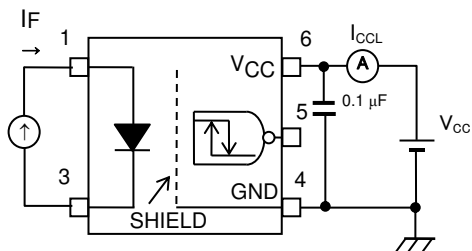

TEST CIRCUIT 4: I_{CCH}

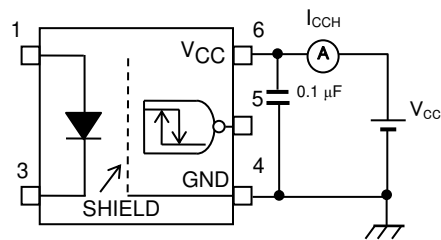

TEST CIRCUIT 5: tpHL, tpLH

$I_F = 12 \text{ mA (P.G)}$
 ($f = 5 \text{ MHz}$, duty = 50%
 less than $t_r = t_f = 5 \text{ ns}$)

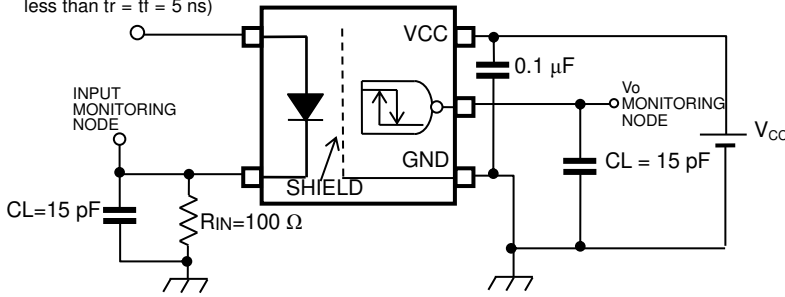

CL is capacitance of the probe and JIG.
 (P.G): Pulse Generator

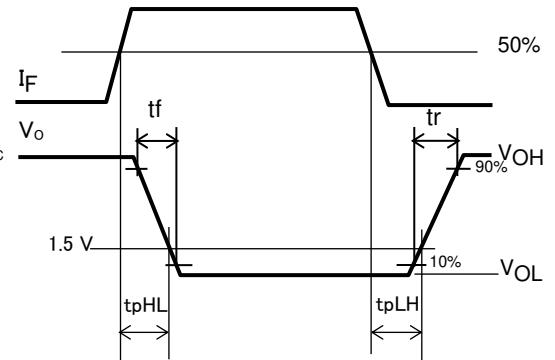

TEST CIRCUIT 6: tpHL, tpLH

$V_{IN} = 5 \text{ V (P.G)}$
 ($f = 5 \text{ MHz}$, duty = 50%
 less than $t_r = t_f = 5 \text{ ns}$)

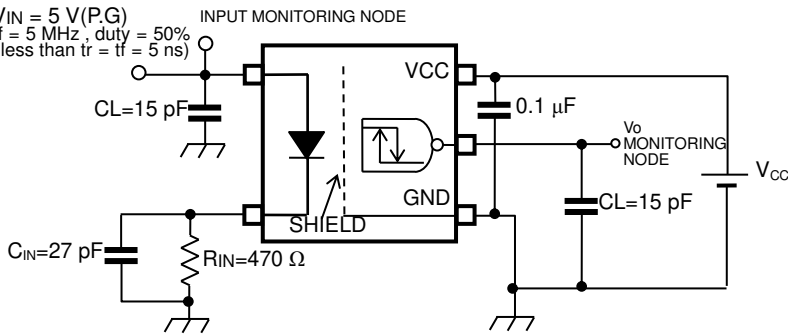

CL is capacitance of the probe and JIG.
 (P.G): Pulse Generator

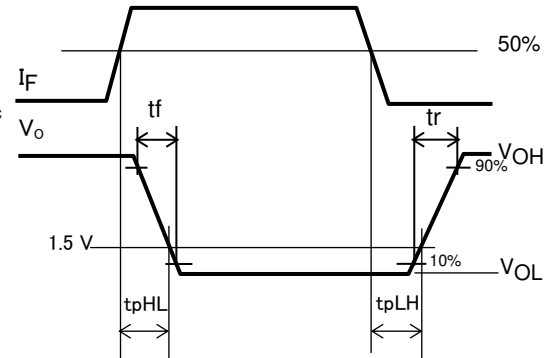

TEST CIRCUIT 7: Common-Mode Transient Immunity Test Circuit

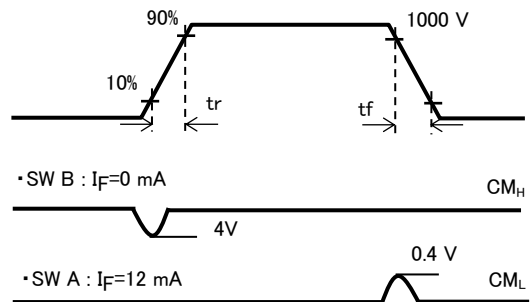
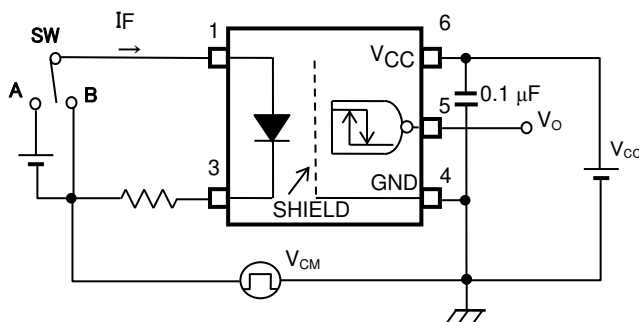

$$CM_H = \frac{800(V)}{t_r(\mu s)} \quad CM_L = \frac{800(V)}{t_f(\mu s)}$$

Soldering and Storage

1. Precautions for Soldering

The soldering temperature should be controlled as closely as possible to the conditions shown below, irrespective of whether a soldering iron or a reflow soldering method is used.

1) When Using Soldering Reflow

An example of a temperature profile when lead(Pb)-free solder is used.

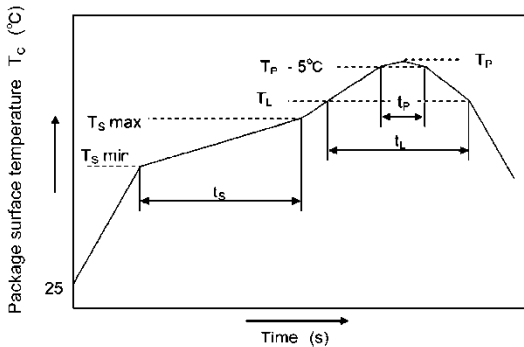

	Symbol	Min	Max	Unit
Preheat temperature	T_s	150	200	°C
Preheat time	t_s	60	120	s
Ramp-up rate (T_L to T_P)			3	°C/s
Liquidus temperature	T_L	217		°C
Time above T_L	t_L	60	150	s
Peak temperature	T_P		260	°C
Time during which T_c is between ($T_P - 5$) and T_P	t_p		30	s
Ramp-down rate (T_P to T_L)			6	°C/s

- The soldering temperature profile is based on the package surface temperature (See the figure shown above.)
- Reflow soldering must be performed once or twice.
- The mounting should be completed with the interval from the first to the last mountings being 2 weeks.

2) When using soldering Flow

- Preheat the device at a temperature of 150 °C (package surface temperature) for 60 to 120 seconds.
- Mounting condition of 260 °C within 10 seconds is recommended
- Flow soldering must be performed once.

3) When using soldering Iron

- Complete soldering within 10 seconds for lead temperature not exceeding 260 °C or within 3 seconds not exceeding 350 °C.
- Heating by soldering iron must be done only once per lead.

2. Precautions for General Storage

- 1) Avoid storage locations where devices may be exposed to moisture or direct sunlight.
- 2) Follow the precautions printed on the packing label of the device for transportation and storage.
- 3) Keep the storage location temperature and humidity within a range of 5°C to 35°C and 45% to 75%, respectively.
- 4) Do not store the products in locations with poisonous gases (especially corrosive gases) or in dusty conditions.
- 5) Store the products in locations with minimal temperature fluctuations. Rapid temperature changes during storage can cause condensation, resulting in lead oxidation or corrosion, which will deteriorate the solderability of the leads.
- 6) When restoring devices after removal from their packing, use anti-static containers.
- 7) Do not allow loads to be applied directly to devices while they are in storage.
- 8) If devices have been stored for more than two years under normal storage conditions, it is recommended that you check the leads for ease of soldering prior to use.

Specification for Embossed-Tape Packing (TPL)(TPR) for SO6 Coupler

1. Applicable Package

Package	Product Type
SO6	Mini-flat coupler

2. Product Naming System

Type of package used for shipment is denoted by a symbol suffix after a product number. The method of classification is as below.

(Example)

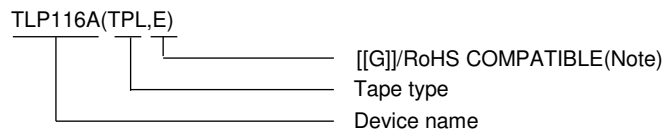

3. Tape Dimensions

3.1 Specification Classification Are as Shown in Table 1

Table 1 Tape Type Classification

Tape type	Classification	Quantity (pcs/reel)
TPL	L direction	3000
TPR	R direction	3000

3.2 Orientation of Device in Relation to Direction of Tape Movement

Device orientation in the recesses is as shown in Figure 1.

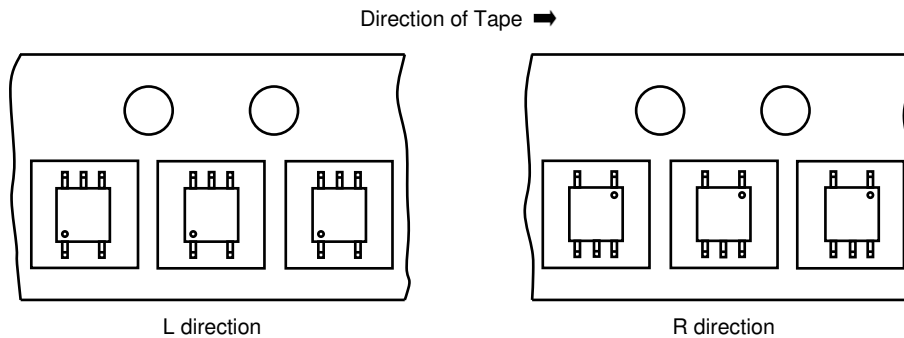

Figure 1 Device Orientation

3.3 Empty Device Recesses Are as Shown in Table 2.

Table 2 Empty Device Recesses

	Standard	Remarks
Occurrences of 2 or more successive empty device recesses	0 device	Within any given 40-mm section of tape, not including leader and trailer
Single empty device recesses	6 devices (max.) per reel	Not including leader and trailer

3.4 Start and End of Tape

The start of the tape has 50 or more empty holes. The end of tape has 50 or more empty holes and two empty turns only for a cover tape.

3.5 Tape Specification

- (1) Tape material: Plastic (protection against electrostatics)
- (2) Dimensions: The tape dimensions are as shown in Figure 2 and Table 3.

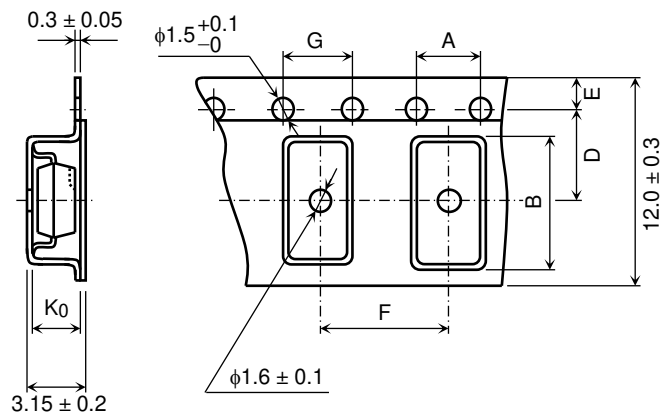

Figure 2 Tape Forms

Table 3 Tape Dimensions

Unit: mm
Unless otherwise specified: ±0.1

Symbol	Dimension	Remark
A	4.2	—
B	7.6	—
D	5.5	Center line of indented square hole and sprocket hole
E	1.75	Distance between tape edge and hole center
F	8.0	Cumulative error $\begin{matrix} +0.1 \\ -0.3 \end{matrix}$ (max) per 10 feed holes
G	4.0	Cumulative error $\begin{matrix} +0.1 \\ -0.3 \end{matrix}$ (max) per 10 feed holes
K ₀	2.8	Internal space

3.6 Reel

- (1) Material: Plastic
- (2) Dimensions: The reel dimensions are as shown in Figure 3 and Table 4.

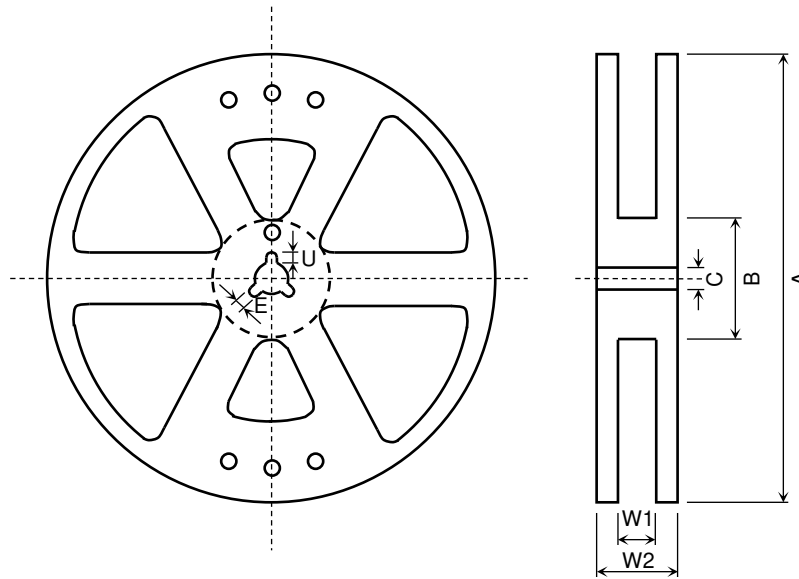

Figure 3 Reel Form

Table 4 Reel Dimensions

Unit: mm

Symbol	Dimension
A	$\Phi 330 \pm 2$
B	$\Phi 80 \pm 1$
C	$\Phi 13 \pm 0.5$
E	2.0 ± 0.5
U	4.0 ± 0.5
W1	13.5 ± 0.5
W2	17.5 ± 1.0

4. Packing

Either one reel or five reels of photocoupler are packed in a shipping carton.

5. Label Indication

The carton bears a label indicating the product number, the symbol representing classification of standard, the quantity, the lot number and the Toshiba company name.

6. Ordering Method

When placing an order, please specify the product number, the tape type and the quantity as shown in the following example.

(Example)

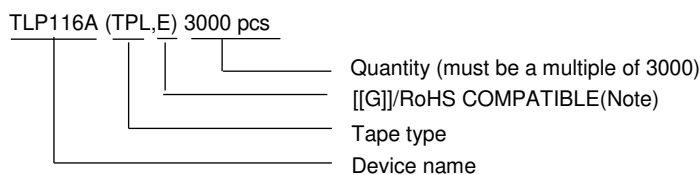

Note : Please contact your TOSHIBA sales representative for details as to environmental matters such as the RoHS compatibility of Product.

The RoHS is the Directive 2011/65/EU of the European Parliament and of the Council of 8 June 2011 on the restriction of the use of certain hazardous substances in electrical and electronic equipment.

RESTRICTIONS ON PRODUCT USE

- Toshiba Corporation, and its subsidiaries and affiliates (collectively "TOSHIBA"), reserve the right to make changes to the information in this document, and related hardware, software and systems (collectively "Product") without notice.
- This document and any information herein may not be reproduced without prior written permission from TOSHIBA. Even with TOSHIBA's written permission, reproduction is permissible only if reproduction is without alteration/omission.
- Though TOSHIBA works continually to improve Product's quality and reliability, Product can malfunction or fail. Customers are responsible for complying with safety standards and for providing adequate designs and safeguards for their hardware, software and systems which minimize risk and avoid situations in which a malfunction or failure of Product could cause loss of human life, bodily injury or damage to property, including data loss or corruption. Before customers use the Product, create designs including the Product, or incorporate the Product into their own applications, customers must also refer to and comply with (a) the latest versions of all relevant TOSHIBA information, including without limitation, this document, the specifications, the data sheets and application notes for Product and the precautions and conditions set forth in the "TOSHIBA Semiconductor Reliability Handbook" and (b) the instructions for the application with which the Product will be used with or for. Customers are solely responsible for all aspects of their own product design or applications, including but not limited to (a) determining the appropriateness of the use of this Product in such design or applications; (b) evaluating and determining the applicability of any information contained in this document, or in charts, diagrams, programs, algorithms, sample application circuits, or any other referenced documents; and (c) validating all operating parameters for such designs and applications. **TOSHIBA ASSUMES NO LIABILITY FOR CUSTOMERS' PRODUCT DESIGN OR APPLICATIONS.**
- **PRODUCT IS NEITHER INTENDED NOR WARRANTED FOR USE IN EQUIPMENTS OR SYSTEMS THAT REQUIRE EXTRAORDINARILY HIGH LEVELS OF QUALITY AND/OR RELIABILITY, AND/OR A MALFUNCTION OR FAILURE OF WHICH MAY CAUSE LOSS OF HUMAN LIFE, BODILY INJURY, SERIOUS PROPERTY DAMAGE AND/OR SERIOUS PUBLIC IMPACT ("UNINTENDED USE").** Except for specific applications as expressly stated in this document, Unintended Use includes, without limitation, equipment used in nuclear facilities, equipment used in the aerospace industry, medical equipment, equipment used for automobiles, trains, ships and other transportation, traffic signaling equipment, equipment used to control combustions or explosions, safety devices, elevators and escalators, devices related to electric power, and equipment used in finance-related fields. **IF YOU USE PRODUCT FOR UNINTENDED USE, TOSHIBA ASSUMES NO LIABILITY FOR PRODUCT.** For details, please contact your TOSHIBA sales representative.
- Do not disassemble, analyze, reverse-engineer, alter, modify, translate or copy Product, whether in whole or in part.
- Product shall not be used for or incorporated into any products or systems whose manufacture, use, or sale is prohibited under any applicable laws or regulations.
- The information contained herein is presented only as guidance for Product use. No responsibility is assumed by TOSHIBA for any infringement of patents or any other intellectual property rights of third parties that may result from the use of Product. No license to any intellectual property right is granted by this document, whether express or implied, by estoppel or otherwise.
- **ABSENT A WRITTEN SIGNED AGREEMENT, EXCEPT AS PROVIDED IN THE RELEVANT TERMS AND CONDITIONS OF SALE FOR PRODUCT, AND TO THE MAXIMUM EXTENT ALLOWABLE BY LAW, TOSHIBA (1) ASSUMES NO LIABILITY WHATSOEVER, INCLUDING WITHOUT LIMITATION, INDIRECT, CONSEQUENTIAL, SPECIAL, OR INCIDENTAL DAMAGES OR LOSS, INCLUDING WITHOUT LIMITATION, LOSS OF PROFITS, LOSS OF OPPORTUNITIES, BUSINESS INTERRUPTION AND LOSS OF DATA, AND (2) DISCLAIMS ANY AND ALL EXPRESS OR IMPLIED WARRANTIES AND CONDITIONS RELATED TO SALE, USE OF PRODUCT, OR INFORMATION, INCLUDING WARRANTIES OR CONDITIONS OF MERCHANTABILITY, FITNESS FOR A PARTICULAR PURPOSE, ACCURACY OF INFORMATION, OR NONINFRINGEMENT.**
- GaAs (Gallium Arsenide) is used in Product. GaAs is harmful to humans if consumed or absorbed, whether in the form of dust or vapor. Handle with care and do not break, cut, crush, grind, dissolve chemically or otherwise expose GaAs in Product.
- Do not use or otherwise make available Product or related software or technology for any military purposes, including without limitation, for the design, development, use, stockpiling or manufacturing of nuclear, chemical, or biological weapons or missile technology products (mass destruction weapons). Product and related software and technology may be controlled under the applicable export laws and regulations including, without limitation, the Japanese Foreign Exchange and Foreign Trade Law and the U.S. Export Administration Regulations. Export and re-export of Product or related software or technology are strictly prohibited except in compliance with all applicable export laws and regulations.
- Please contact your TOSHIBA sales representative for details as to environmental matters such as the RoHS compatibility of Product. Please use Product in compliance with all applicable laws and regulations that regulate the inclusion or use of controlled substances, including without limitation, the EU RoHS Directive. **TOSHIBA ASSUMES NO LIABILITY FOR DAMAGES OR LOSSES OCCURRING AS A RESULT OF NONCOMPLIANCE WITH APPLICABLE LAWS AND REGULATIONS.**