

PART NUMBER	REVISION	DESCRIPTION	FEED TYPE
2150360-1	B	FINE CRIMP HEIGHT ADJUST	MECHANICAL
2150360-2	B	FINE CRIMP HEIGHT ADJUST	PNEUMATIC
7-2150360-1	B	MECHANICAL AND CRIMP TOOLING KIT	MECHANICAL
7-2150360-2	B	PNEUMATIC AND CRIMP TOOLING KIT	PNEUMATIC
7-2150360-7	A	CRIMP TOOLING KIT	-

ATLANTIC VERSION TERMINATOR INTERFACE ADAPTER

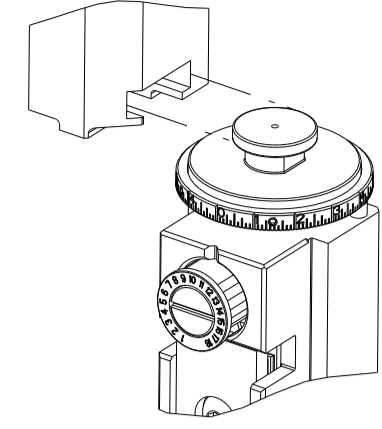

APPLICATOR DATA		
CRIMP	SIZE	TYPE
WIRE	1.07 mm [.042]	F
INSUL	1.78 mm [.070]	F

APPLICATOR INSTRUCTIONS 408-35043

TERMINAL DATA: TE TERMINAL TE CRIMP SPECIFICATION			
TERMINAL NAME: RING TONGUE			
WIRE STRIP LENGTH	INSULATION DIAMETER RANGE		
2.30-2.90 mm [.091-.114 IN]	∅0.76-1.27 mm [.030-.050 IN]		
TERMINAL APPLICATION SPECIFICATION	114-2084		
TERMINALS APPLIED			
TE TERMINAL	TE TERMINAL	TE TERMINAL	TE TERMINAL
160562-1	160562-2		

WIRE SIZE	CRIMP HEIGHT mm [INCH]	CRIMP HEIGHT REFERENCE SETTING
26 AWG	0.96 +/- 0.000 [.038 +/- .000]	4.8
28 AWG	0.92 +/- 0.000 [.036 +/- .000]	5.2

- 1. RECOMMENDED SPARE PARTS
- 2. REFER TO SUPPLIED INSTRUCTION SHEET FOR CLEANING, LUBRICATION AND STORAGE OF APPLICATOR.
- 3. APPLY PART NUMBER 2-23419-6 LOCTITE TO THREADS OF ITEM 242.
- 4. CRIMP HEIGHT REFERENCE SETTING WAS THE SETTING USED WHEN THE APPLICATOR WAS QUALIFIED AT THE FACTORY. ADJUSTMENT MAY BE NECESSARY WHEN RUNNING APPLICATOR IN THE FIELD.
- 5. UNLESS SPECIFIED OTHERWISE TORQUE VALUES SHALL BE USED PER DOCUMENT, 101-35000.

***WARNING**
 ON INSTALLATION, SET WIRE DISC TO CRIMP HEIGHT REFERENCE SETTING FOR LARGEST WIRE SIZE. CRIMP HEIGHT REFERENCE SETTINGS GREATER THAN THE VALUE SHOWN MAY CAUSE DAMAGE TO THE CRIMP TOOLING, REFER TO THE INSTRUCTION SHEET FOR PROPER SETUP AND ADJUSTMENTS.

ATLANTIC VERSION
 Shown on sheets 1 of 4 & 2 of 4
 (Pacific version shown on sheets 3 of 4 & 4 of 4)

LOC	DIST	REVISIONS					
A	66	P	LTN	DESCRIPTION	DATE	DWN	APVD
		A		RELEASED	28OCT2013	KH	UG
		B		ECR-21-006818	12JUL2021	FZ	TE

-	1	-	1	-	2119641-1	FEED CAM, AIR FEED	248	
-	1	1	1	1	2119082-9	CAM, SNAIL, INSULATION ADJUSTMENT	244	
-	1	1	1	1	2079764-1	WASHER, WAVE SPRING, CREST-TO-CREST	243	
-	1	1	1	1	2119083-1	RETAINER, INSULATION DIAL	242	
-	-	1	-	1	2119580-1	MECHANICAL FEED ASSEMBLY	239	
-	1	-	1	-	2844940-3	AIR FEED MODULE	238	
-	1	1	1	1	1-18028-0	WASHER, FLAT, REG M8	192	
-	REF	REF	REF	REF	994970-2	COUNTER, MAGNETIC	164	
-	1	1	1	1	455888-5	SPACER, CRIMPER	82	
-	1	1	1	1	2119791-9	DEPRESSOR, WIRE	73	
-	1	1	1	1	1803607-4	DOCUMENTATION PACKAGE	71	
-	2	2	2	2	2-18032-2	SCR, SET, FLT PNT, M3 X 10.0	70	
-	1	1	1	1	2119740-1	TAG, IDENTIFICATION	67	
-	2	2	2	2	2168078-1	SCREW, DRIVE, RH, RoHS, 2 x .188	66	
-	1	1	1	1	2168083-2	SCR, SKT HD CAP, RoHS, M4 X 8.0	60	
-	1	1	1	1	5-18022-5	SCR, HEX HD CAP, M4 X 6.0	59	
-	-	1	-	1	2063961-1	FEED FINGER	58	
-	4	4	4	4	2168400-4	SHCS, LOW HEAD, RoHS, M4 X 8	57	
-	2	2	2	2	1-2168083-4	SCR, SKT HD CAP, RoHS, M4 X 5	56	
-	2	2	2	2	5018030-1	NUT, HEX, REG, RoHS, M3	54	
-	2	2	2	2	986965-8	NUT, LOCK, HEX, TORQUE (M4)	53	
-	1	-	1	-	2063961-9	FEED FINGER	51	
-	1	2	1	2	18023-9	SCR, SKT HD CAP M4 X 6.0	49	
-	-	1	-	1	2119652-1	FEED CAM, PRE FEED	48	
-	-	1	-	1	2119653-1	FEED CAM, POST FEED	47	
-	1	1	1	1	2119655-5	APPLICATOR BASIC ASSEMBLY, EF	46	
-	1	1	1	1	1803517-1	RAM ASSEMBLY, EF ATLANTIC	44	
-	1	1	1	1	1803602-1	SCR, BHSC, RoHS (M8 X 25)	41	
-	8	8	8	8	1-18028-2	WASHER, FLAT, REG M4	33	
-	2	2	2	2	2168083-8	SCR, SKT HD CAP, RoHS, M4 X 16	31	
-	2	2	2	2	2168083-2	SCR, SKT HD CAP, RoHS, M4 X 8.0	29	
-	1	1	1	1	240639-1	STRIPPER (MACHINING)	27	
-	2	2	2	2	1-2168083-5	SCR, SKT HD CAP, RoHS, M4 X 30	25	
-	1	1	1	1	1752371-2	PLATE, STRIP GUIDE	24	
-	2	2	2	2	2-22281-3	SPRING, COMPRESSION	22	
-	1	1	1	1	1803292-4	DRAG	20	
-	1	1	1	1	1901696-8	STRIP GUIDE, REAR	19	
-	1	1	1	1	1901695-8	STRIP GUIDE, FRONT	18	
-	4	4	4	4	1-2079383-1	SCR, BHSC, RoHS (M6 X 12)	17	
-	1	1	1	1	691901-2	REAR SHEAR PLATE, REVERSIBLE	11	
-	2	2	2	2	240645-2	SPACER, SHEAR PLATE	10	
-	1	1	1	1	240642-1	PLATE, FRONT SHEAR	9	
-	1	2	2	1	1	3-1803000-4	ANVIL, COMBINATION, END FEED	8
-	1	1	1	1	2-691157-4	BLADE, SHEAR	7	
-	-	-	-	-	-	-	6	
-	1	1	1	1	3-240641-8	SPACER	5	
-	1	1	1	1	238011-7	BLOCK, CRIMPER SPACER	4	
-	1	2	2	1	1	2-1803017-2	CRIMPER, INSULATION F	3
-	1	1	1	1	455888-3	SPACER, CRIMPER	2	
-	1	2	2	1	1	456401-5	CRIMPER, WIRE .042 F PREMIUM	1
-	77	72	71	2	-1	PART NO	ITEM NO	

DIMENSIONS:		TOLERANCES UNLESS OTHERWISE SPECIFIED:		MATERIAL:		FINISH:		WEIGHT:		SCALE:		SHEET:		REV:	
mm	0 PLC ±	1 PLC ±	2 PLC ±	3 PLC ±	4 PLC ±	ANGLES	FINISH			A	00779	1	4	B	

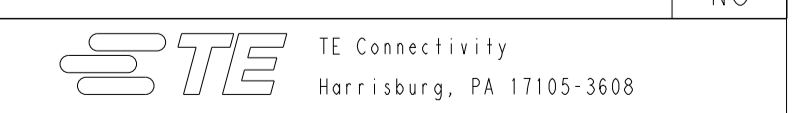

Ocean End Feed Applicator

Customer Accessible Production Drawing

LOC	DIST	REVISIONS					
A	66	P	LTM	DESCRIPTION	DATE	OWN	APVD
		-		SEE SHEET 1			

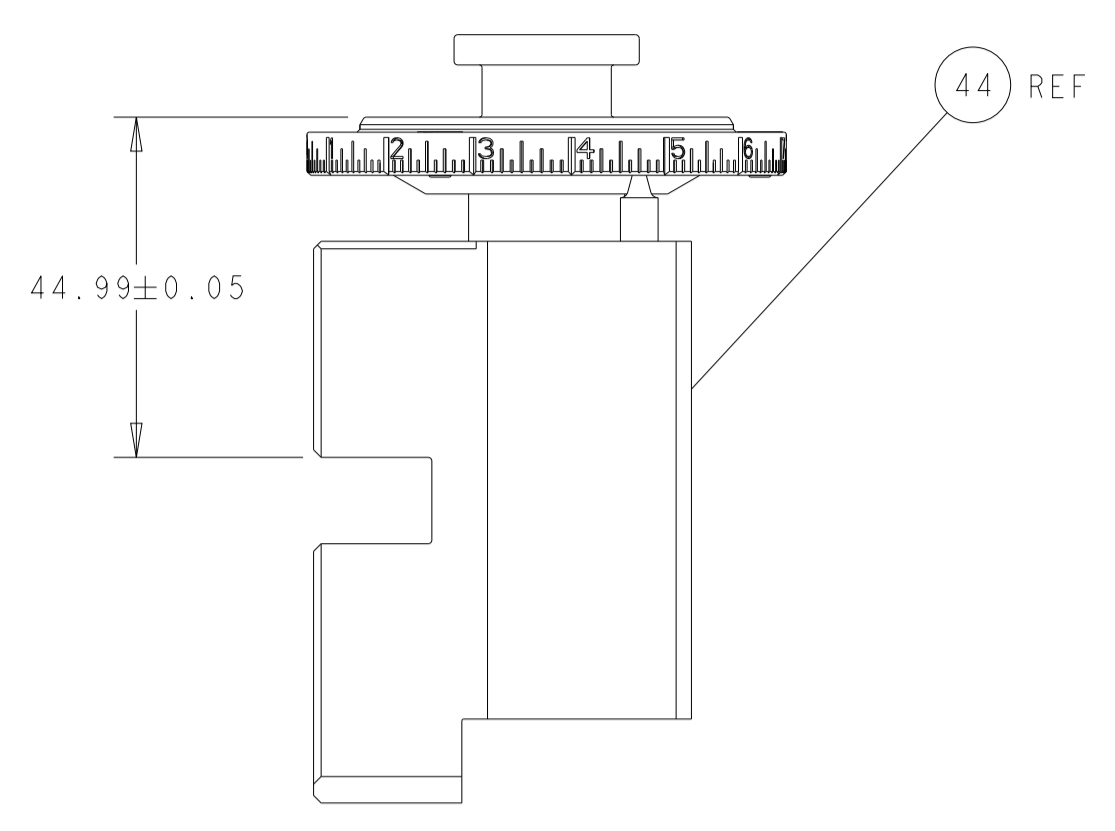

RAM SET-UP

FEED TYPE
MECHANICAL

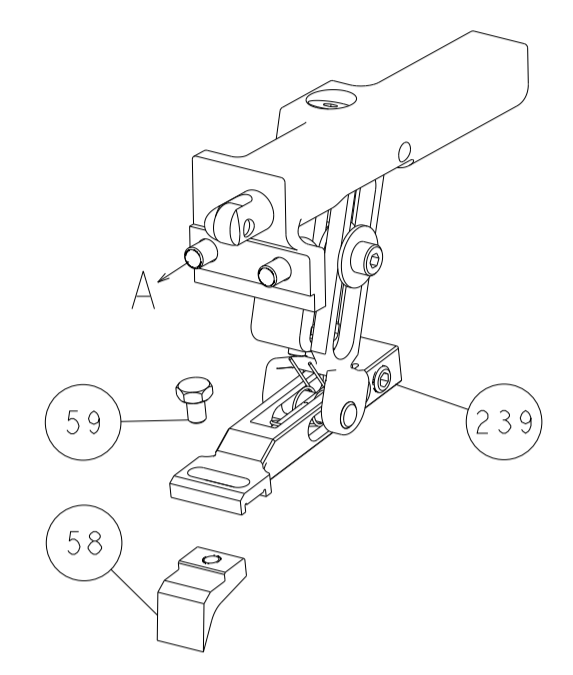

PNEUMATIC

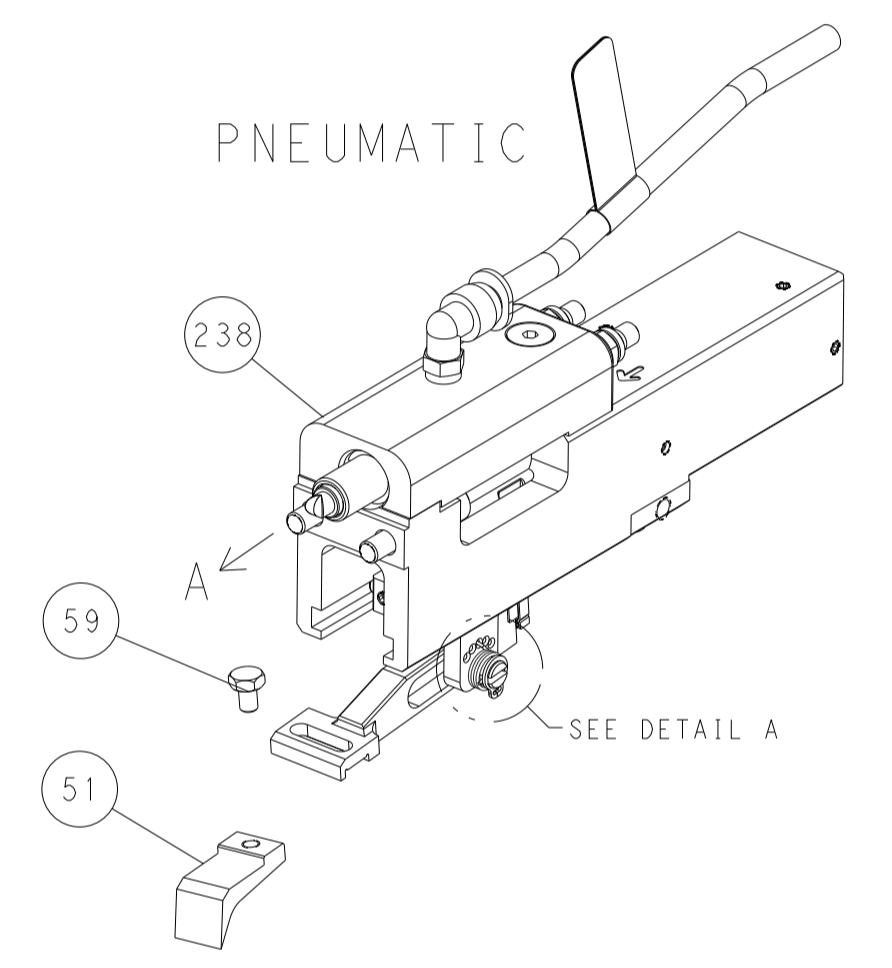

FEED SPRING
SETTING POSITION

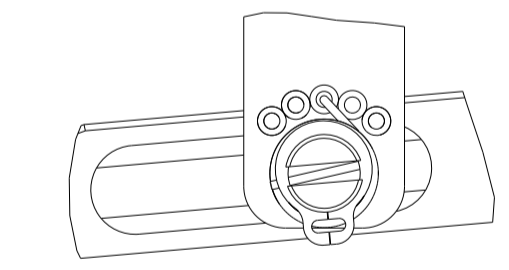

DETAIL A

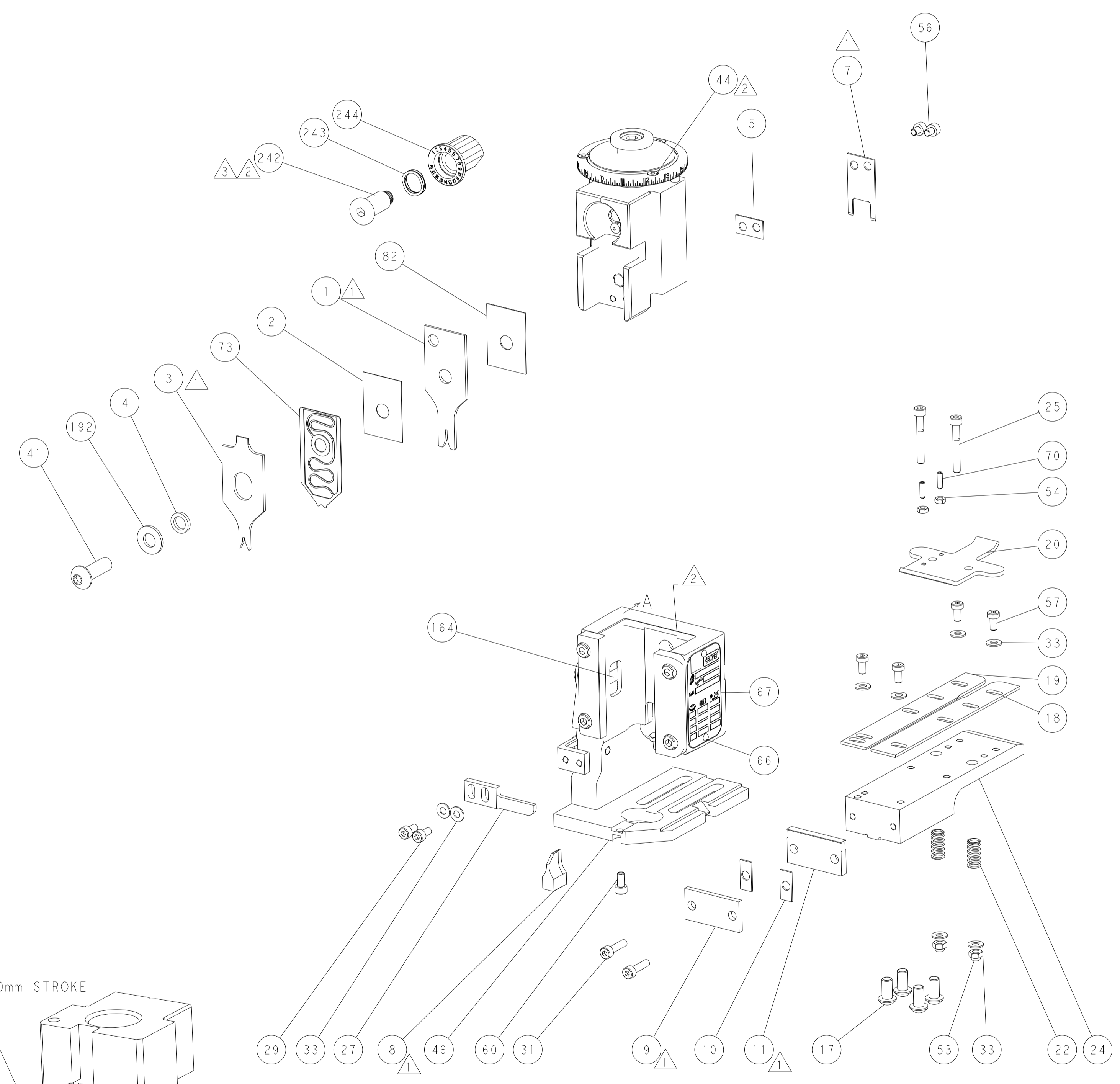

CAM POSITIONS

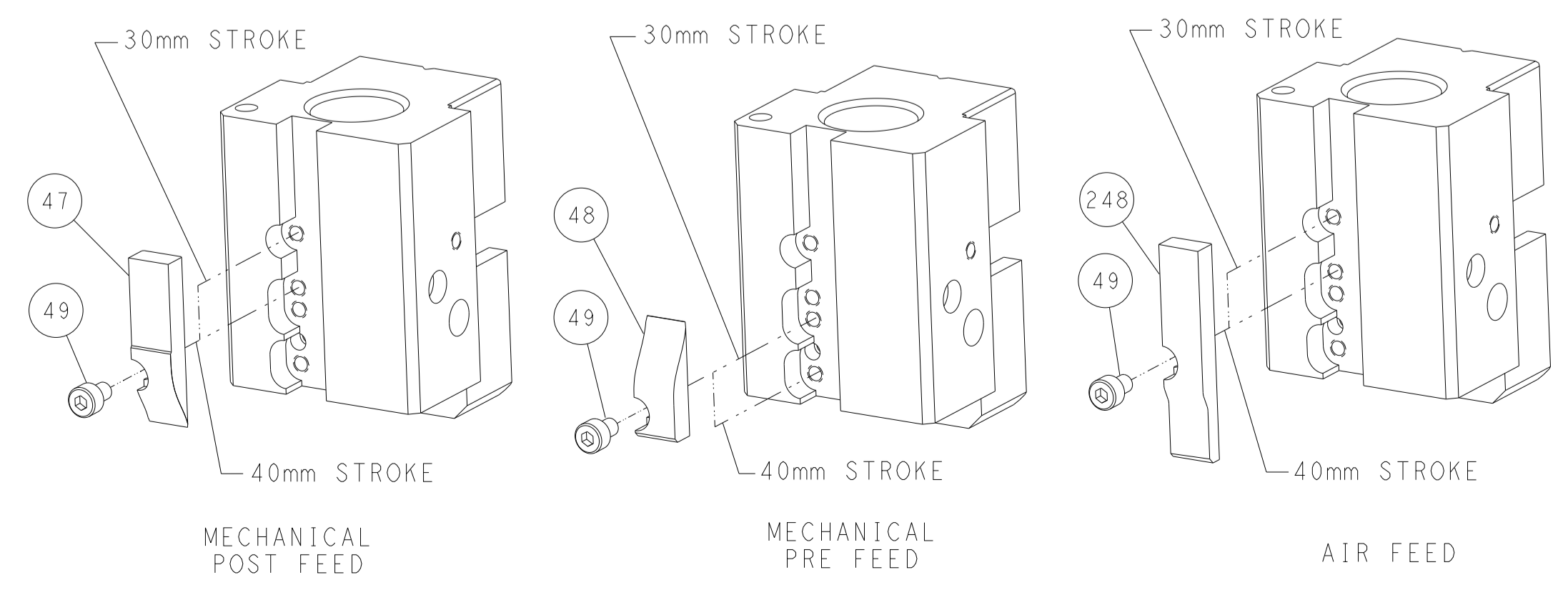

ATLANTIC VERSION
 Shown on sheets 1 of 4 & 2 of 4
 (Pacific version shown on sheets 3 of 4 & 4 of 4)

<small>THIS DRAWING IS A CONTROLLED DOCUMENT FOR TYCO ELECTRONICS CORPORATION. IT IS THE PROPERTY OF TYCO ELECTRONICS CORPORATION AND IS NOT TO BE REPRODUCED OR TRANSMITTED IN ANY FORM OR BY ANY MEANS, ELECTRONIC OR MECHANICAL, INCLUDING PHOTOCOPYING, RECORDING, OR BY ANY INFORMATION STORAGE AND RETRIEVAL SYSTEM, WITHOUT THE WRITTEN PERMISSION OF TYCO ELECTRONICS CORPORATION.</small>		DWN K. HUANG 04SEP2013 CHK L. ZHANG 04SEP2013 APVD J. GUO 04SEP2013	TE Connectivity Harrisburg, PA 17105-3608
DIMENSIONS: mm TOLERANCES UNLESS OTHERWISE SPECIFIED: 0 PLC ± 1 PLC ± 2 PLC ± 3 PLC ± 4 PLC ± ANGLES FINISH ±		NAME Ocean End Feed Applicator PRODUCT SPEC APPLICATION SPEC WEIGHT SCALE 1:1	SIZE A1 CAGE CODE 00779 DRAWING NO. C=2150360 SHEET 2 OF 4 REV B
MATERIAL:		Customer Accessible Production Drawing	

THIS DRAWING IS UNPUBLISHED.	RELEASED FOR PUBLICATION		
COPYRIGHT 20 BY TYCO ELECTRONICS CORPORATION. ALL RIGHTS RESERVED.			
PART NUMBER	REVISION	DESCRIPTION	FEED TYPE
2-2150360-1	B	FINE CRIMP HEIGHT ADJUST	MECHANICAL
2-2150360-2	B	FINE CRIMP HEIGHT ADJUST	PNEUMATIC
7-2150360-7	A	CRIMP TOOLING KIT	-

PACIFIC VERSION TERMINATOR
INTERFACE ADAPTER

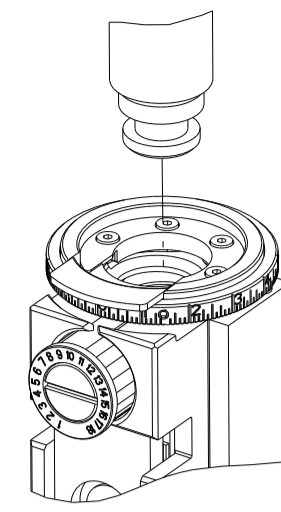

APPLICATOR DATA		
CRIMP	SIZE	TYPE
WIRE	1.07 mm [.042]	F
INSUL	1.78 mm [.070]	F
APPLICATOR INSTRUCTIONS 408-35043		

TERMINAL DATA: TE TERMINAL		TE CRIMP SPECIFICATION	
TERMINAL NAME: RING TONGUE			
WIRE STRIP LENGTH 2.30-2.90 mm [.091-.114 IN]		INSULATION DIAMETER RANGE Ø0.76-1.27 mm [.030-.050 IN]	
TERMINAL APPLICATION SPECIFICATION 114-2084			
TERMINALS APPLIED			
TE TERMINAL	TE TERMINAL	TE TERMINAL	TE TERMINAL
160562-1	160562-2		

WIRE SIZE	CRIMP HEIGHT mm [INCH]	CRIMP HEIGHT REFERENCE SETTING
26 AWG	0.96+/-0.000 [.038+/- .000]	4.8
28 AWG	0.92+/-0.000 [.036+/- .000]	5.2

- 1 RECOMMENDED SPARE PARTS
- 2 REFER TO SUPPLIED INSTRUCTION SHEET FOR CLEANING, LUBRICATION AND STORAGE OF APPLICATOR.
- 3 APPLY PART NUMBER 2-23419-6 LOCTITE TO THREADS OF ITEM 242.
- 4 CRIMP HEIGHT REFERENCE SETTING WAS THE SETTING USED WHEN THE APPLICATOR WAS QUALIFIED AT THE FACTORY. ADJUSTMENT MAY BE NECESSARY WHEN RUNNING APPLICATOR IN THE FIELD.
- 5. UNLESS SPECIFIED OTHERWISE TORQUE VALUES SHALL BE USED PER DOCUMENT, 101-35000.

***WARNING**
ON INSTALLATION, SET WIRE DISC TO CRIMP HEIGHT REFERENCE SETTING FOR LARGEST WIRE SIZE. CRIMP HEIGHT REFERENCE SETTINGS GREATER THAN THE VALUE SHOWN MAY CAUSE DAMAGE TO THE CRIMP TOOLING, REFER TO THE INSTRUCTION SHEET FOR PROPER SETUP AND ADJUSTMENTS.

PACIFIC VERSION
Shown on sheets 3 of 4 & 4 of 4
(Atlantic version shown on sheets 1 of 4 & 2 of 4)

LOC	DIST	REVISIONS					
A	66	P	LTN	DESCRIPTION	DATE	DWN	APVD
		-		SEE SHEET 1			

-	1	1	2119082-9	CAM, SNAIL, INSULATION ADJUSTMENT	244	
-	1	1	2079764-1	WASHER, WAVE SPRING, CREST-TO-CREST	243	
-	1	1	2119083-1	RETAINER, INSULATION DIAL	242	
-	-	1	2119580-1	MECHANICAL FEED ASSEMBLY	239	
-	1	-	2844940-3	AIR FEED MODULE	238	
-	1	1	1-18028-0	WASHER, FLAT, REG M8	192	
-	4	4	2079383-9	SCR, BHSC, RoHS (M6 X 20)	186	
-	REF	REF	994970-2	COUNTER, MAGNETIC	164	
-	1	-	2119641-2	FEED CAM, AIR FEED	152	
-	1	1	2168083-8	SCR, SKT HD CAP, RoHS, M4 X 16	144	
-	-	1	2119653-2	FEED CAM, POST FEED	142	
-	1	1	2119655-6	APPLICATOR BASIC ASSEMBLY, EF	141	
-	1	1	1803518-1	RAM ASSEMBLY, EF PACIFIC	140	
-	1	1	455888-5	SPACER, CRIMPER	82	
-	1	1	2119791-9	DEPRESSOR, WIRE	73	
-	1	1	1803607-4	DOCUMENTATION PACKAGE	71	
-	2	2	2-18032-2	SCR, SET, FLT PNT, M3 X 10.0	70	
-	1	1	2119740-1	TAG, IDENTIFICATION	67	
-	2	2	2168078-1	SCREW, DRIVE, RH, RoHS, 2 x .188	66	
-	1	1	5-18022-5	SCR, HEX HD CAP, M4 X 6.0	59	
-	-	1	2063961-1	FEED FINGER	58	
-	4	4	2168400-4	SHCS, LOW HEAD, RoHS, M4 X 8	57	
-	2	2	1-2168083-4	SCR, SKT HD CAP, RoHS, M4 X 5	56	
-	2	2	5018030-1	NUT, HEX, REG, RoHS, M3	54	
-	2	2	986965-8	NUT, LOCK, HEX, TORQUE (M4)	53	
-	1	-	2063961-9	FEED FINGER	51	
-	1	2	18023-9	SCR, SKT HD CAP M4 X 6.0	49	
-	-	1	2119652-1	FEED CAM, PRE FEED	48	
-	1	1	1803602-1	SCR, BHSC, RoHS (M8 X 25)	41	
-	8	8	1-18028-2	WASHER, FLAT, REG M4	33	
-	2	2	2168083-8	SCR, SKT HD CAP, RoHS, M4 X 16	31	
-	2	2	2168083-2	SCR, SKT HD CAP, RoHS, M4 X 8.0	29	
-	1	1	240639-1	STRIPPER (MACHINING)	27	
-	2	2	1-2168083-5	SCR, SKT HD CAP, RoHS, M4 X 30	25	
-	1	1	1752371-2	PLATE, STRIP GUIDE	24	
-	2	2	2-22281-3	SPRING, COMPRESSION	22	
-	1	1	1803292-4	DRAG	20	
-	1	1	1901696-8	STRIP GUIDE, REAR	19	
-	1	1	1901695-8	STRIP GUIDE, FRONT	18	
-	1	1	691901-2	REAR SHEAR PLATE, REVERSIBLE	11	
-	2	2	240645-2	SPACER, SHEAR PLATE	10	
-	1	1	240642-1	PLATE, FRONT SHEAR	9	
-	1	1	3-1803000-4	ANVIL, COMBINATION, END FEED	8	
-	1	1	2-691157-4	BLADE, SHEAR	7	
-	-	-	-	-	6	
-	1	1	3-240641-8	SPACER	5	
-	1	1	238011-7	BLOCK, CRIMPER SPACER	4	
-	1	1	2-1803017-2	CRIMPER, INSULATION F	3	
-	1	1	455888-3	SPACER, CRIMPER	2	
-	1	1	456401-5	CRIMPER, WIRE .042 F PREMIUM	1	
-	77	22	21	PART NO	DESCRIPTION	ITEM NO

DIMENSIONS: mm		TOLERANCES UNLESS OTHERWISE SPECIFIED:		DWN: H. HUANG 04SEP2013		CHK: L. ZHANG 04SEP2013		NAME: U. GUO 04SEP2013		APVD: U. GUO 04SEP2013		PRODUCT SPEC		APPLICATION SPEC		SIZE: A1		CAGE CODE: 00779		DRAWING NO: ©=2150360		RESTRICTED TO: -	
MATERIAL: -		FINISH: -		WEIGHT: -		SCALE: 1:1		SHEET: 3		OF: 4		REV: B		Customer Accessible Production Drawing									

LOC		DIST		REVISIONS			
A	66	P	LTM	DESCRIPTION	DATE	OWN	APVD
		-		SEE SHEET 1			

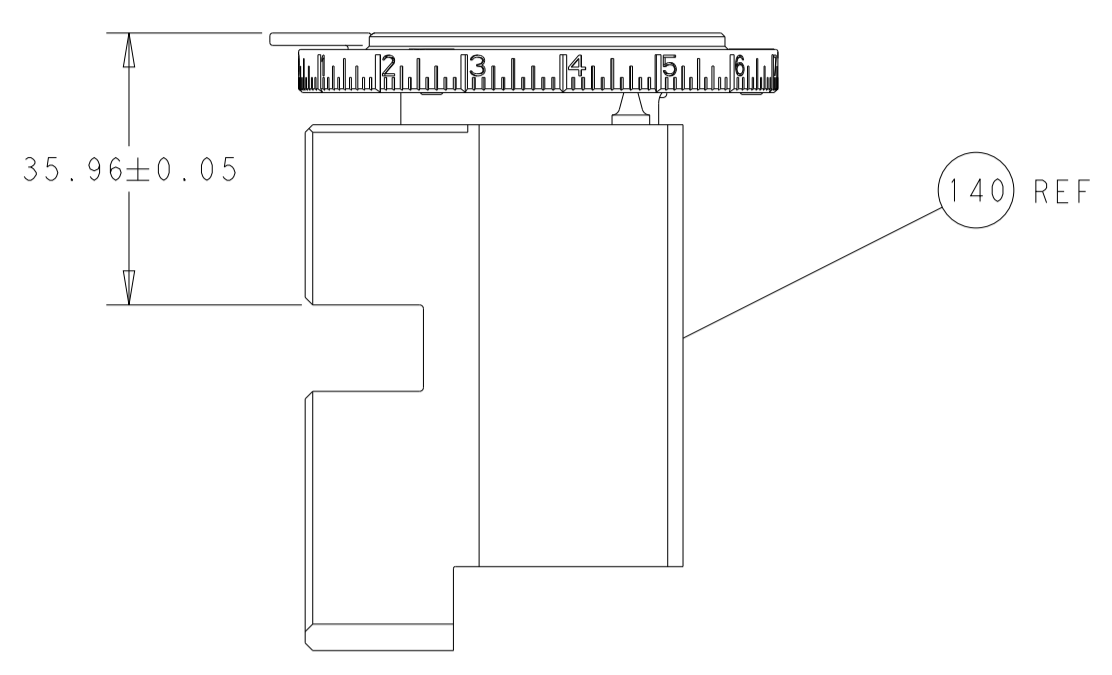

RAM SET-UP

FEED TYPE
MECHANICAL

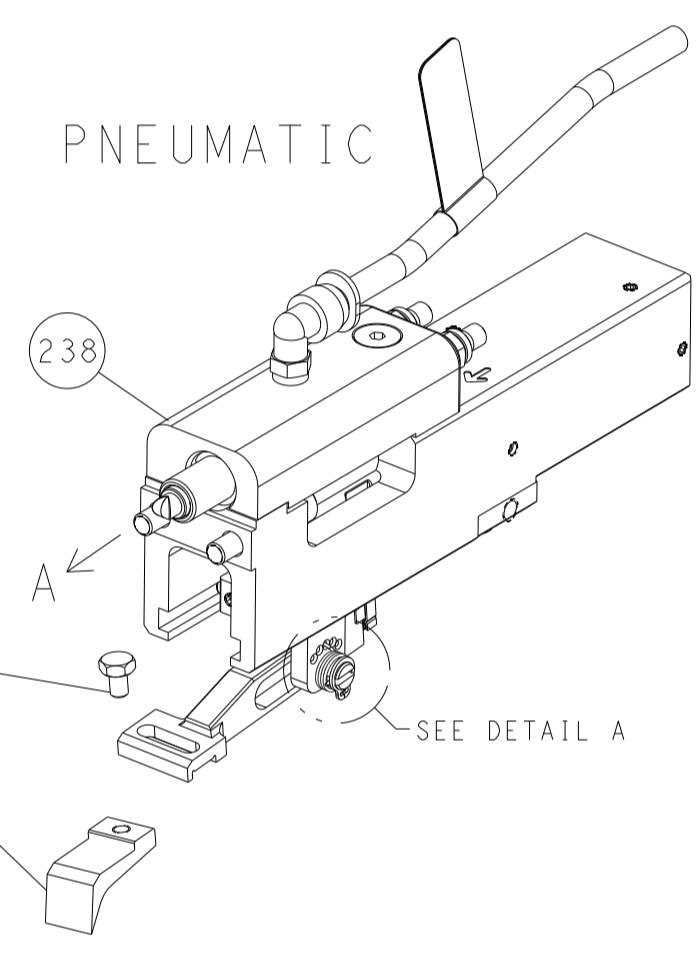
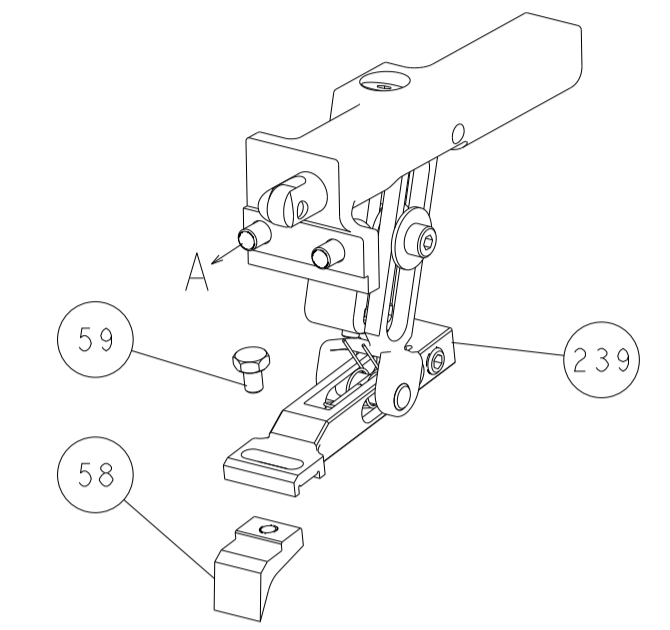

PNEUMATIC

FEED SPRING
SETTING POSITION

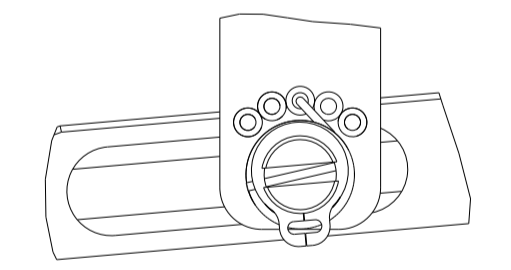

DETAIL A

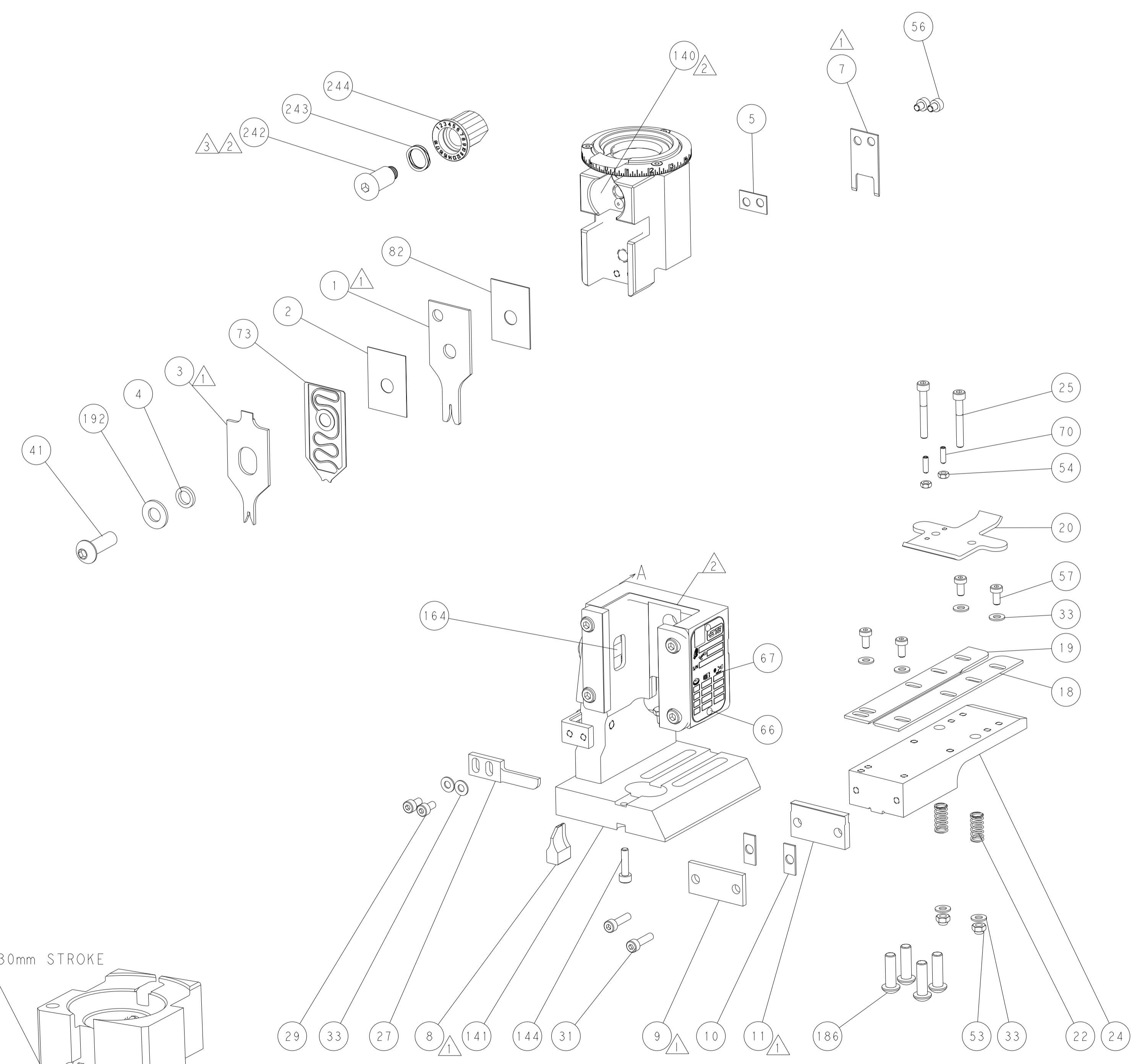

CAM POSITIONS

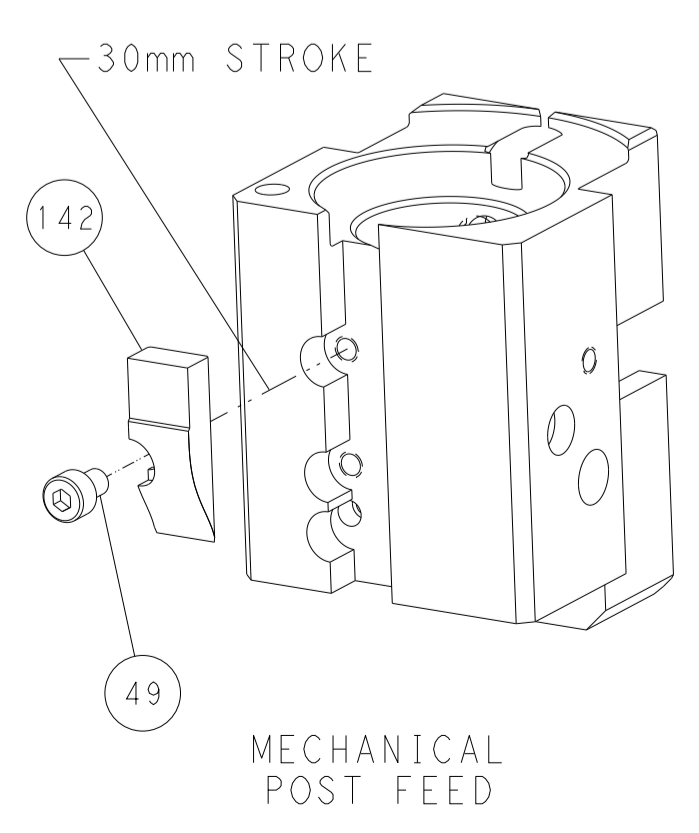

MECHANICAL
POST FEED

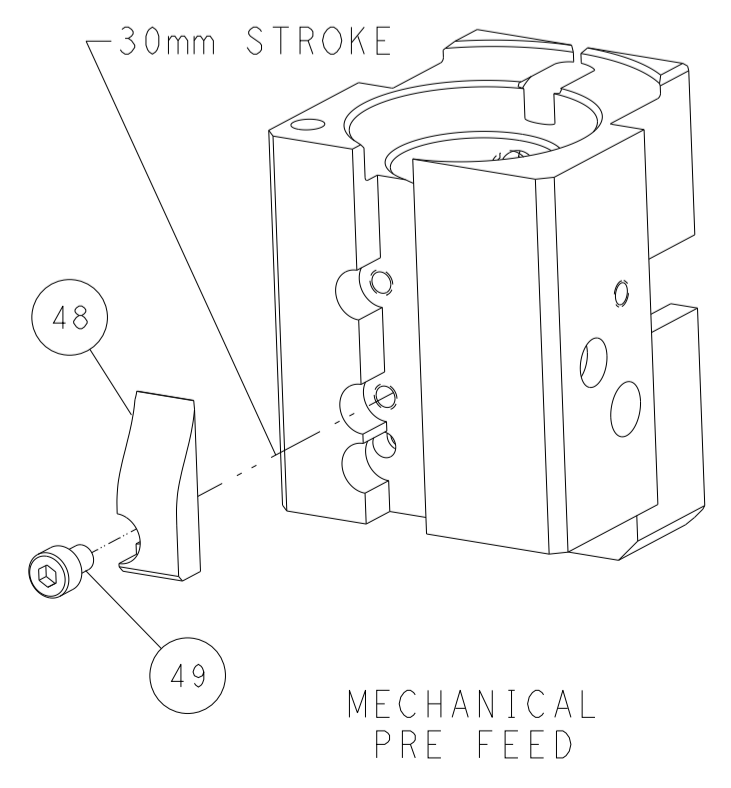

MECHANICAL
PRE FEED

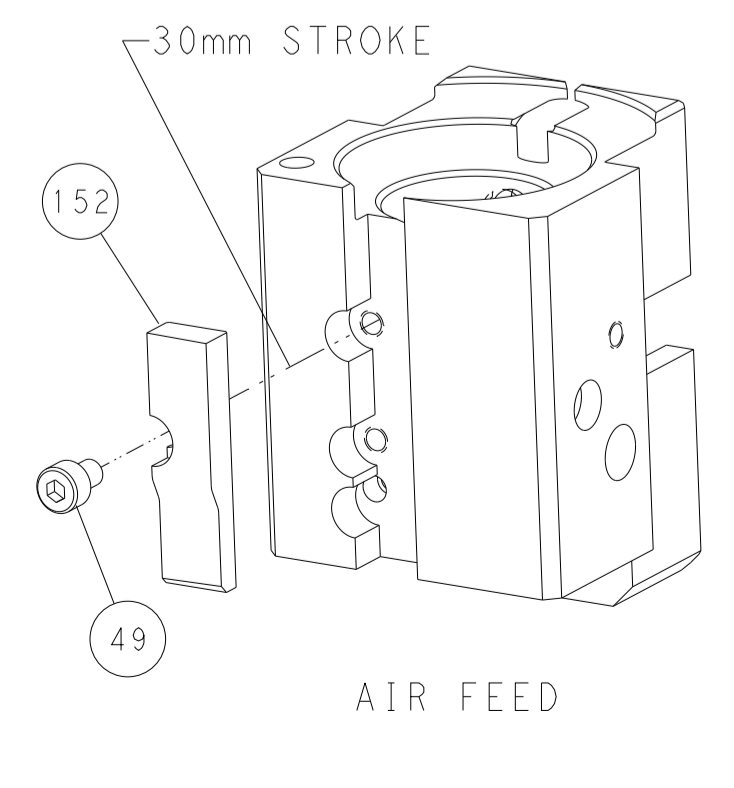

AIR FEED

PACIFIC VERSION
 Shown on sheets 3 of 4 & 4 of 4
 (Atlantic version shown on sheets 1 of 4 & 2 of 4)

DIMENSIONS:		TOLERANCES UNLESS OTHERWISE SPECIFIED:		OWN: K. HUANG 04SEP2013		CHK: L. ZHANG 04SEP2013		NAME: STE TE Connectivity Harrisburg, PA 17105-3608	
mm	0 PLC ±	1 PLC ±	2 PLC ±	3 PLC ±	4 PLC ±	APVD: J. GUO 04SEP2013	PRODUCT SPEC	APPLICATION SPEC	RESTRICTED TO
MATERIAL:	FINISH:	WEIGHT:	SCALE: 1:1	SHEET: 4	OF: 4	REV: B	Customer Accessible Production Drawing		