

DRAWING MADE IN THIRD ANGLE PROJECTION

680602 ← 680602

/home/us016926/DMECmod

PART NUMBER	REV	FIRST USED
680602-1	D	122500-1
680602-2	D	565435-5
680602-3	D	354500-1

THIS DRAWING IS A CONTROLLED DOCUMENT

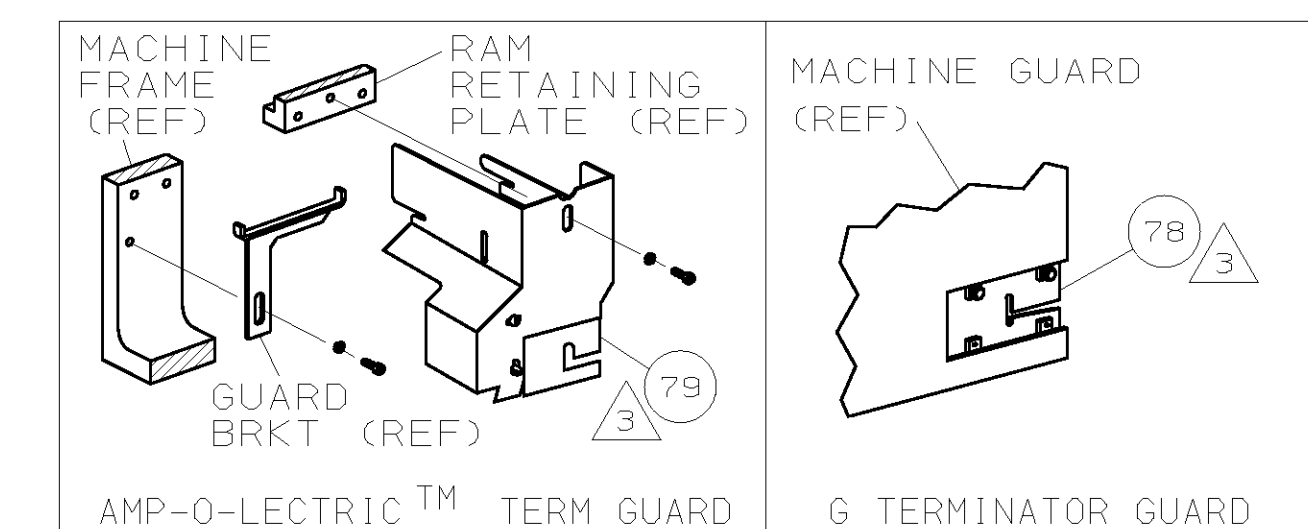
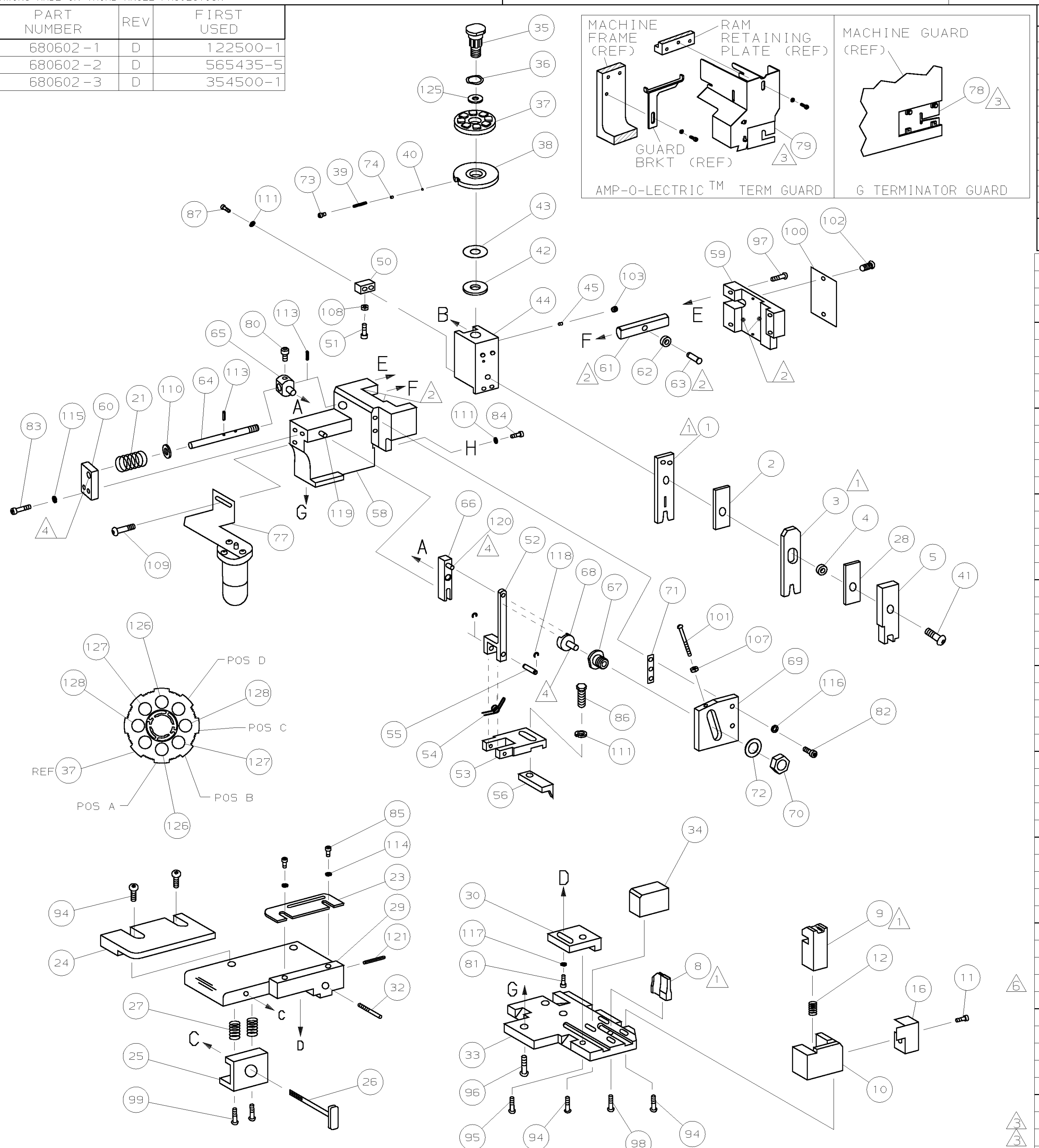

TERMINAL NAME: TYPE III + PIN AND SOCKET					
SOCKET		PIN		CRIMPING DATA	
788088		788085		PAD LTR	CRIMP HEIGHT
				A	.025 ±.001 [0.64 ±0.03mm]
				B	.024 ±.001 [0.61 ±0.03mm]
				C	NOT USED
				D	NOT USED
				CRIMP	SIZE
				WIRE	.055 [1.40mm]
				INSUL	.055 [1.40mm]
WIRE STRIP LENGTH	TERM APPL SPEC	FEED	APPL INSTRUCTION	SET UP GAGE	LAYOUT
.141-.172	114-10004	.500	408-8040	458637-1	L18480

QTY	REF	REF	REF	REF	PART NO	DESCRIPTION	ITEM NO
							129
							128
2	2	2	-	C	7-354779-4	PIN, WIRE DISC (.3360)B	127
2	2	2	-	C	7-354779-2	PIN, WIRE DISC (.3350)A	126
1	1	1	-	A	986950-1	WASHER, FLAT PRECISION	125
1	1	1	-	A	217238-1	GENERAL INSTRUCTION PACKAGE	124
1	1	1	-	-	4088040	SF APPL INST 408-8040	123
							122
1	1	1	-	A	4-21028-0	PIN, SLT SPR (φ.093x.75) ST GDE PL	121
REF	REF	REF	-	A	1-21030-1	PIN, DOWEL (φ.187x.50) LEVER	120
REF	REF	REF	-	A	1-21030-6	PIN, DOWEL (φ.187x1.25) HOUSING	119
REF	REF	REF	-	A	21045-3	RING, RET "C" (φ.187) FD FING PIN	118
1	1	1	-	A	21024-5	WASHER, LOCK (#10) ADJ BLK	117
REF	REF	REF	-	A	21024-5	WASHER, LOCK (#10) ADJ PLATE	116
REF	REF	REF	-	A	21024-5	WASHER, LOCK (#10) FEED GDE ROD	115
2	2	2	-	A	21024-2	WASHER, LOCK (#4) FRONT STP GUIDE	114
REF	REF	REF	-	A	5-21028-1	PIN, SLT SPR (φ.125x.50) ADJ ROD	113
							112
4	4	4	-	A	21024-4	WASHER, LOCK (#8) STRIPPER	111
REF	REF	REF	-	A	21899-4	WASHER, FLAT (φ5/16) SCREW ADJ	110
-	1	-	-	A	2-21002-6	SCR, BHC (10-32x.38) LUBE ASSY	109
1	1	1	-	A	21018-5	NUT, HEX (NO. 6) HOLDDOWN	108
REF	REF	REF	-	A	21018-5	NUT, HEX (6-32) FEED ADJ	107
							106
							105
1	1	-	-	A	992031-1	PIN, CLEVIS	104
1	1	1	-	A	21009-2	SCR, SKT 5ET (1/4-20x.25 LW) RAM	103
2	2	2	-	A	21017-2	SCR, DRIVE (#2x.19) ID PLATE	102
REF	REF	REF	-	A	6-23715-5	SCR, PAN HD (6-32x1.50) FEED ADJ	101
1	1	1	-	B	461264-1	PLATE, IDENTIFICATION	100
2	2	2	-	A	3-21002-0	SCR, BHC (10-32x.88) DRAG	99
1	1	1	-	A	22733-8	SCR, BHC (8-32x.38 LW) ANVIL	98
REF	REF	REF	-	A	2-21002-9	SCR, BHC (10-32x.75) CAP	97
REF	REF	REF	-	A	2-22733-8	SCR, BHC (1/4-20x.62) HOUSING	96
REF	REF	REF	-	A	2-21002-7	SCR, BHC (10-32x.50) 56 ADJ BLOCK	95
6	6	6	-	A	2-21002-2	SCR, BHC (8-32x.50) TERM H DWN	94
							93
							92
1	1	1	-	A	1-21002-7	SCR, BHC (6-32x.38) CAM	91
							90
1	1	-	-	A	7-21000-9	SCR, SHC (4-40x.19) STRIPPER	89
							88
2	2	2	-	A	2-21000-7	SCR, SHC (8-32x.48) DEP-HOLD	87
1	1	1	-	A	2-22603-0	SCR, HEX HD (8-32x.31) FEED FINGER	86
2	2	2	-	A	1-21000-3	SCR, SHC (4-40x.25) F ST GUIDE	85
1	1	1	-	A	2-21000-7	SCR, SHC (8-32x.50) STRIPPER	84
REF	REF	REF	-	A	3-21000-7	SCR, SHC (10-32x.75) FEED ROD GD	83
REF	REF	REF	-	A	3-21000-6	SCR, SHC (10-32x.62) FD ADJ BLK	82
1	1	1	-	A	3-21000-4	SCR, SHC (10-32x.38) 56 ADJ BL	81
REF	REF	REF	-	A	3-21000-4	SCR, SHC (10-32x.38) PIVOT BLK	80
-	REF	-	-	B	455749-1	GUARD, WINDOW	79
REF	-	-	-	B	679532-1	INSERT, GUARD	78
-	1	-	-	C	1-465184-0	LUBRICATOR ASSY	77
							76
							75
1	1	1	-	A	690603-1	SPRING, ASSIST	74
1	1	1	-	A	23030-1	SCR, SHC (6-32x.25 SL) INS DISC	73
REF	REF	REF	-	A	458109-1	WASHER, SPECIAL	72
REF	REF	REF	-	A	690517-1	SPACER	71
-3	-2	-1	U/M	DWG SIZE	PART NO	DESCRIPTION	ITEM NO
QTY REOD PER ASSY						PARTS LIST	

LEADMAKER						MECH POST FEED						
-1	REF	REF	REF	-	B	22594-8						70
-2	REF	REF	REF	-	B	240628-1						69
-3	REF	REF	REF	-	B	240626-1						68
	REF	REF	REF	-	B	240633-1						67
	REF	REF	REF	-	A	455680-1						66
	REF	REF	REF	-	B	240629-1						65
	REF	REF	REF	-	A	240632-2						64
	REF	REF	REF	-	B	240659-3						63
	REF	REF	REF	-	B	240658-1						62
	REF	REF	REF	-	B	454398-2						61
	REF	REF	REF	-	A	454178-1						60
	REF	REF	REF	-	C	454220-1						59
	REF	REF	REF	-	D	454485-1						58
												57
1	1	1	-	B	458537-2	PAWL, FEED						56
REF	REF	REF	-	B	240624-1	PIN, FEED FINGER						55
REF	REF	REF	-	B	691499-1	SPRING, FEED FINGER						54
REF	REF	REF	-	B	690541-1	HOLDER, FEED FINGER						53
REF	REF	REF	-	A	455679-1	LEVER, TERMINAL FEED ARM						52
1	1	1	-	A	811242-2	BUMPER, HOLDDOWN						51
1	1	1	-	A	690753-1	SPACER, TONKER						50
1	-	-	-	B	690602-6	CAM, PRE-FEED 1 5/8 ST						49
-	1	-	-	B	690602-5	CAM, PRE-FEED 1 1/8 ST						48
-	-	1	-	B	690501-4	CAM, POST-FEED 1 5/8 ST						47
1	1	1	-	B	459456-1	APPLICATOR, BASIC (SUBASSY)						46
1	1	1	-	A	690191-1	PLUG, NYLON						45
1	1	1	-	C	455673-1	RAM						44
1	1	1	-	A	690125-1	WASHER, LAMINATED						43
1	1	1	-	A	1-690124-4	WASHER, RAM						42
1	1	1	-	A	7-21002-9	BOLT, CRIMPER (5/16x1.00)						41
1	1	1	-	A	23241-6	BALL, STEEL						40
1	1	1	-	A	690170-1	SPRING, COMPRESSION						39
1	1	1	-	C	690142-1	DISC, INSULATION						38
1	1	1	-	D	354777-1	WIRE DISC, PLASTIC						37
1	1	1	-	A	22480-5	WASHER, SPRING						36
1	1	1	-	B	690212-1	POST, RAM						35
1	1	1	-	B	692776-2	SUPPORT, TERMINAL						34
REF	REF	REF	-	D	455675-1	PLATE, BASE						33
1	1	1	-	A	690432-3	SCREW, ADJUSTMENT						32
												31
REF	REF	REF	-	B	455689-1	BLOCK, STRIP GUIDE ADJ						30
1	1	1	-	C	455671-1	PLATE, STRIP GUIDE						29
1	1	1	-	C	2-455888-1	SPACER, FRONT SHEAR DEP						28
2	2	2	-	A	1-22284-0	SPRING, DRAG						27
1	1	1	-	B	690546-1	LEVER, DRAG RELEASE						26
1	1	1	-	B	240792-1	DRAG, TERMINAL						25
1	1	1	-	D	5-690504-9	GUIDE, STRIP (REAR)						24
1	1	1	-	A	690438-1	GUIDE, STRIP (FRONT)						23
-	-	1	-	B	690472-8	STRIPPER						22
REF	REF	REF	-	A	4-22284-9	SPRING, FEED RETURN						21
1	1	-	-	A	679218-1	STRIPPER WIRE STOP ASSY						20
1	1	-	-	B	458949-2	STRIPPER						19
												18
												17
1	1	1	-	B	318563-1	GUARD, CHIP, FRONT						16
												15
												14
												13
1	1	1	-	A	5-22280-0	SPRING, SHEAR						12
1	1	1	-	B	690461-1	STOP, SHEAR						11
1	1	1	-	C	690459-1	HOLDER, SHEAR (FRONT)						10
1	1	1	-	C	462006-1	SHEAR, FLOAT (FRONT)						9
1	1	1	-	C	662183-5	ANVIL						8
												7
												6
1	1	1	-	C	2-455889-0	DEPRESSOR, SHEAR (FRONT)						5
1	1	1	-	B	238011-7	SPACER,						