

NOTICE OF PROPRIETARY RIGHTS THIS DOCUMENT CONTAINS CONFIDENTIAL TECHNICAL DATA, INCLUDING TRADE SECRETS, PROPRIETARY TO TIMES MICROWAVE SYSTEMS. DISCLOSURE OF THIS DATA IS EXPRESSLY CONDITIONED UPON YOUR ASSENT THAT ITS USE IS LIMITED TO USE WITHIN YOUR COMPANY ONLY. ANY OTHER USE IS STRICTLY PROHIBITED WITHOUT THE PRIOR WRITTEN CONSENT OF TIMES MICROWAVE SYSTEMS.

SYM	REVISION DESCRIPTION	DFTM	DATE	APPD	DATE
A	RELEASED FOR PRODUCTION	JCL	11/6/01	J. C. L	11/6/01
B	CHANGED PER CDC #38124	N.N.N	7/26/13	J. D. B	8/12/13
C	CHANGED PER CDC #43049	N.N.N	9/16/15	J. D. B	9/16/15

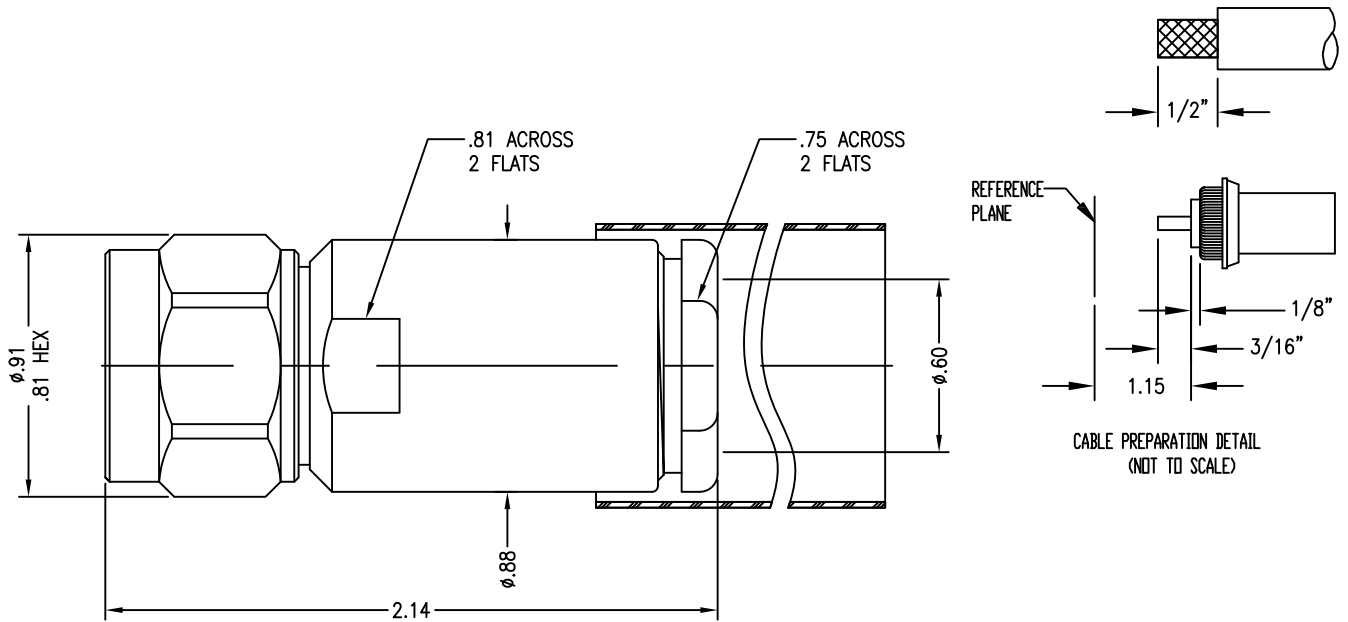

- 1.0 PERFORMANCE
 - 1.1 FREQUENCY RANGE: DC TO 6 GHz
 - 1.2 NOMINAL IMPEDANCE: 50 OHMS
 - 1.3 DWV: 2500 VRMS @ 60 Hz (SEA LEVEL)
 - 1.4 TEMPERATURE RANGE: -65°C TO +165°C
- 2.0 MATERIALS
 - 2.1 DIELECTRIC: PTFE
 - 2.2 CONTACT: BRASS
 - 2.3 LOCKING RING: PHOSPHOR BRONZE
 - 2.4 OTHER METAL PARTS: BRASS
 - 2.5 GASKETS: SILICONE RUBBER
 - 2.6 SHRINK SLEEVE: THICK WALL POLYOLEFIN
- 3.0 FINISHES: SEE TABLE
- 4.0 MECHANICAL
 - 4.1 INTERFACE PER MIL-STD-348

BODY	CONTACT	C'NUT
SILVER	GOLD	NICKEL

MATERIAL: SEE ABOVE	UNLESS OTHERWISE SPECIFIED	DFTM. J. C. L	TIMES MICROWAVE SYSTEMS	
	ALL DIMENSIONS ARE IN INCHES MACHINED SURFACES FINISH 32 RMS MAX. REMOVE ALL BURRS .005 MAX. BREAK MACHINE CORNERS .005 MAX. FILLET R. TOLERANCES ON DECIMALS . XX ± .01 . XXX ± .005 ANGLES ± 1° FRACTIONS ± 1/64	DATE 11/6/01		
USED ON: C		CHKD. J. C. L	TC-600-NMC TYPE-N MALE (PLUG) FOR LMR-600 CABLE	
		DATE 11/6/01		
SCALE: ~	DWG. SIZE A	APPD. J. C. L	SHEET 1 of 1 SD3190-357 REV C	
DO NOT SCALE DRAWING	CODE IDENT 68999	DATE 11/6/01		