

③ **USB2.0 COMPLIANT**

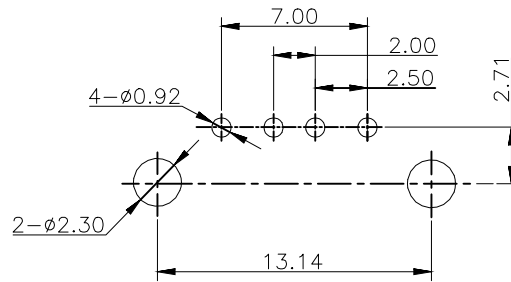
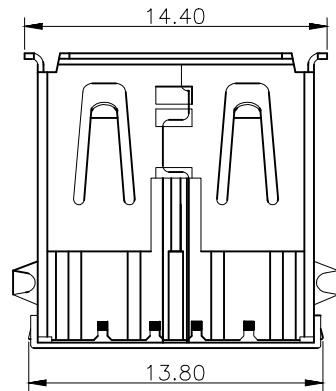
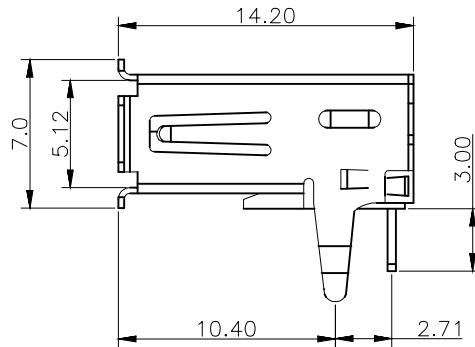
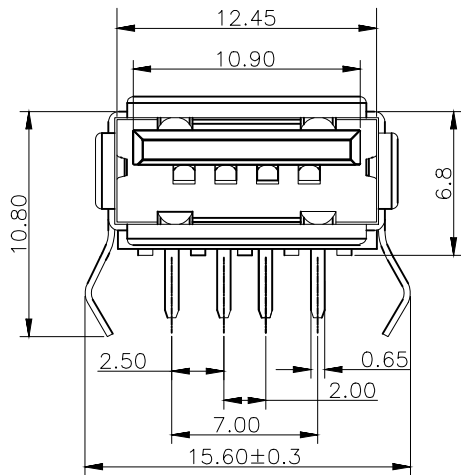

RECOMMENDED P.C.B. LAYOUT
(TOLERANCE:±0.05)

NOTES:

- 1.Material:
 - 1.1 Housing: PBT+30%GF UL94V-0, Color White
 - 1.2 Shell: Brass
 - 1.3 Contact :Phosphor Bronze
- 2. FINISH:
 - 2.1 Contact Area: Selective 5u"Au
 - Solder Area: Tin Plated
 - Under: Ni Plated
- 3.MECHANICAL:
 - 3.1 Mating Force:3.57kgf Max.
 - 3.2 Unmating Force:1.02kgf Min
 - 3.3 Durability:1500 cycles Min
- 4.ELECTRICAL:
 - 4.1 Current Rating:1.5A
 - 4.2 Dielectric Strength:500V AC FOR 1 MINUTE
 - 4.3 Contact Resistance:30mΩ Max
 - 4.4 Insulation Resistance:1000 MΩ Min
 - ④ 4.5 Voltage Rating: 30VAC
- ② 5.Operating temperature: -55°C TO +85°C
- ④ 6.Soldering temperature :235°C ,5S max
- 7.PACKIING: Tray

RoHS compliant

Scale	Free					Date	Name	Customer-No.
TOLERANCE		④	Update	08.11.2019	Carson	Drawn	Winnie	ASSMANN WSW-No. ① AU-Y1005
.X	±0.30	③	Update	24.07.2019	Xavier	Approved	Carson	
.XX	±0.20	②	Add the wave soldering temperature &time	20.03.2017	Winnie			
.XXX	±0.10	①	Change the P/N AU-Y1005-R to AU-Y1005	25.11.2013	Winnie			Drawing-No.
DIM	TOL	①						ASS 5773 CO
X.°	±5°	①	Drawn	07.06.2013	Winnie			
Angle	TOL	①						Replace
UNIT	mm	Id.	Modification	Date	Name			SHEET

