

■ Features :

- Universal AC input / Full range
- Built-in active PFC function, PF>0.96
- Protections: Short circuit / Overload / Over voltage
- Protections:Over temperature(option)
- Cooling by free air convection
- 100% full load burn-in test
- Fixed switching frequency at PFC:67KHz PWM:134KHz
- 3 years warranty



■ GTIN CODE

MW Search: <https://www.meanwell.com/serviceGTIN.aspx>



SPECIFICATION

MODEL	LPP-150-3.3	LPP-150-5	LPP-150-7.5	LPP-150-12	LPP-150-13.5	LPP-150-15	LPP-150-24	LPP-150-27	LPP-150-48		
OUTPUT	DC VOLTAGE	3.3V	5V	7.5V	12V	13.5V	15V	24V	27V	48V	
	RATED CURRENT	30A	30A	20A	12.5A	11.2A	10A	6.3A	5.6A	3.2A	
	CURRENT RANGE	0 ~ 30A	0 ~ 30A	0 ~ 20A	0 ~ 12.5A	0 ~ 11.2A	0 ~ 10A	0 ~ 6.3A	0 ~ 5.6A	0 ~ 3.2A	
	RATED POWER	99W	150W	150W	150W	151.2W	150W	151.2W	151.2W	153.6W	
	RIPPLE & NOISE (max.) Note.2	100mVp-p	100mVp-p	100mVp-p	100mVp-p	100mVp-p	100mVp-p	150mVp-p	150mVp-p	250mVp-p	
	VOLTAGE ADJ. RANGE	3.14 ~ 3.63V	4.75 ~ 5.5V	7.13 ~ 8.25V	11.4 ~ 13.2V	12.8 ~ 14.9V	14.3 ~ 16.5V	22.8 ~ 26.4V	25.7 ~ 29.7V	45.6 ~ 52.8V	
	VOLTAGE TOLERANCE Note.3	±2.0%	±2.0%	±2.0%	±2.0%	±2.0%	±2.0%	±1.0%	±1.0%	±1.0%	
	LINE REGULATION	±0.5%	±0.5%	±0.5%	±0.5%	±0.5%	±0.5%	±0.5%	±0.5%	±0.5%	
	LOAD REGULATION	±1.0%	±1.0%	±1.0%	±1.0%	±1.0%	±1.0%	±0.5%	±0.5%	±0.5%	
	SETUP, RISE TIME	600ms, 30ms at full load									
HOLD UP TIME (Typ.)	30ms at full load										
INPUT	VOLTAGE RANGE	85 ~ 264VAC		120 ~ 370VDC							
	FREQUENCY RANGE	47 ~ 63Hz									
	POWER FACTOR	PF ≥ 0.96/230VAC			PF ≥ 0.97/115VAC at full load						
	EFFICIENCY(Typ.)	70%	76%	80%	82%	83%	83%	85%	85%	85%	
	AC CURRENT (Typ.)	2.5A/115VAC		1.2A/230VAC							
	INRUSH CURRENT (Typ.)	COLD START 55A/230VAC									
	LEAKAGE CURRENT	<3.5mA / 240VAC									
PROTECTION	OVERLOAD	105 ~ 150% rated output power Protection type : Constant current limiting, recovers automatically after fault condition is removed									
	OVER VOLTAGE	3.63 ~ 4.45V	5.5 ~ 6.75V	8.25 ~ 10.1V	13.2 ~ 16.2V	14.85 ~ 18.2V	16.5 ~ 20.25V	26.4 ~ 32.4V	29.7 ~ 36.5V	52.8 ~ 64.8V	
ENVIRONMENT	WORKING TEMP.	-10 ~ +60°C with cooling FAN (Refer to "Derating Curve")									
	WORKING HUMIDITY	20 ~ 90% RH non-condensing									
	STORAGE TEMP., HUMIDITY	-20 ~ +85°C, 10 ~ 95% RH									
	TEMP. COEFFICIENT	±0.05%/°C (0 ~ 50°C)									
	VIBRATION	10 ~ 500Hz, 2G 10min./1cycle, period for 60min. each along X, Y, Z axes									
SAFETY & EMC (Note 4)	SAFETY STANDARDS	UL62368-1, TUV BS EN/EN62368-1, EAC TP TC 004 approved									
	WITHSTAND VOLTAGE	I/P-O/P:3KVAC			I/P-FG:2KVAC		O/P-FG:0.5KVAC				
	ISOLATION RESISTANCE	I/P-O/P, I/P-FG, O/P-FG:100M Ohms / 500VDC / 25°C / 70% RH									
	EMC EMISSION	Compliance to BS EN/EN55032 (CISPR32) Class B, BS EN/EN61000-3-2,-3, EAC TP TC 020									
	EMC IMMUNITY	Compliance to BS EN/EN61000-4-2,3,4,5,6,8,11, BS EN/EN55035, light industry level, EAC TP TC 020									
OTHERS	MTBF	2635.3K hrs min. Telcordia SR-332 (Bellcore) ; 292.7K hrs min.			MIL-HDBK-217F (25°C)						
	DIMENSION	222*75*41mm (L*W*H)									
	PACKING	0.62Kg; 24pcs/16.6Kg/1.63CUFT									
NOTE	<ol style="list-style-type: none"> 1. All parameters NOT specially mentioned are measured at 230VAC input, rated load and 25°C of ambient temperature. 2. Ripple & noise are measured at 20MHz of bandwidth by using a 12" twisted pair-wire terminated with a 0.1uf & 47uf parallel capacitor. 3. Tolerance : includes set up tolerance, line regulation and load regulation. 4. The power supply is considered a component which will be installed into a final equipment. All the EMC tests are been executed by mounting the unit on a 360mm*360mm metal plate with 1mm of thickness. The final equipment must be re-confirmed that it still meets EMC directives. For guidance on how to perform these EMC tests, please refer to "EMI testing of component power supplies." (as available on http://www.meanwell.com) 5. The ambient temperature derating of 3.5°C/1000m with fanless models and of 5°C/1000m with fan models for operating altitude higher than 2000m(6500ft). ※ Product Liability Disclaimer : For detailed information, please refer to https://www.meanwell.com/serviceDisclaimer.aspx										

■ Mechanical Specification

Unit:mm

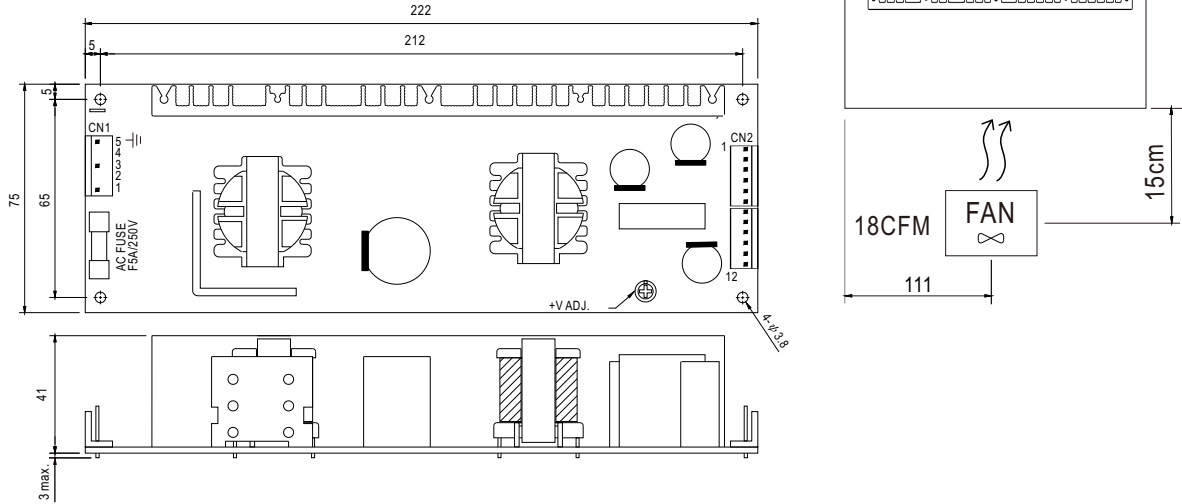

AC Input Connector (CN1) : JST B5P-VH or equivalent

Pin No.	Assignment	Mating Housing	Terminal
1	AC/L	JST VHR or equivalent	JST SVH-21T-P1.1 or equivalent
2,4	No Pin		
3	AC/N		
5	FG \perp		

DC Output Connector (CN2) : JST B6P-VH*2 or equivalent

Pin No.	Assignment	Mating Housing	Terminal
1~6	-V	JST VHR or equivalent	JST SVH-21T-P1.1 or equivalent
7~12	+V		

\perp : Grounding Required
CN1: Pin 5 is safety ground

■ Block Diagram

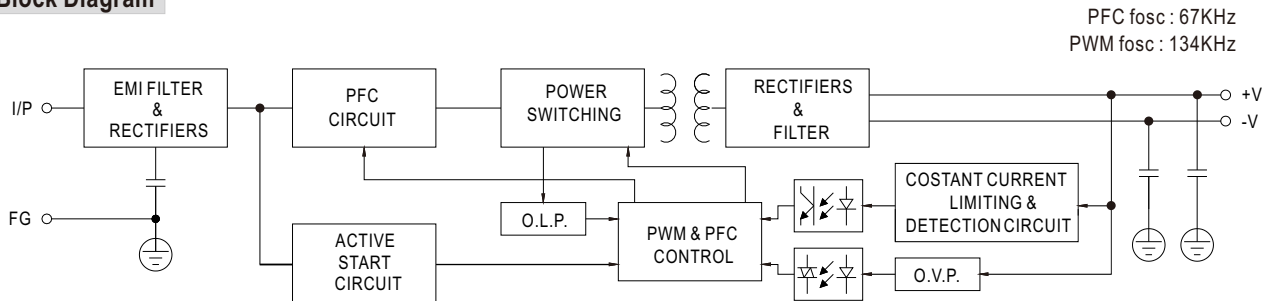

■ Derating Curve

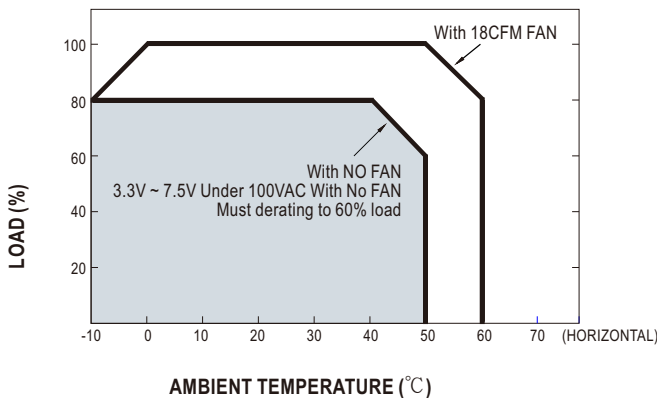

■ Output Derating VS Input Voltage

