

| PART NUMBER | REV | TERMINATOR | FEED TYPE | DESCRIPTION |
|-------------|-----|------------|----------------|--------------------|
| 1426576-1 | A | LEADMAKER | MECH POST FEED | CUTS CARRIER |
| 1426576-2 | A | BENCH | MECH PRE FEED | CUTS CARRIER |
| 1426576-6 | A | LEADMAKER | MECH POST FEED | CONTINUOUS CARRIER |
| 7-1426576-1 | A | LEADMAKER | MECH POST FEED | -1 AND SPARE PARTS |
| 7-1426576-2 | A | BENCH | MECH PRE FEED | -2 AND SPARE PARTS |
| 7-1426576-6 | A | LEADMAKER | MECH POST FEED | -6 AND SPARE PARTS |
| 7-1426576-7 | A | - | - | SPARE PARTS KIT |

| CRIMP | SIZE | TYPE | RANGE |
|-------|-----------------|------|--|
| WIRE | 1.78 [1.070 IN] | F | 0.50mm ² -1.50mm ² |
| INSUL | 3.56 [1.140 IN] | O | 2.30-3.00 [1.091-1.118 IN] |

| WIRE STRIP LENGTH | APPL INSTRUCTIONS |
|----------------------------|-------------------|
| 3.80-4.60 [1.150-1.181 IN] | 408-8322 |

| TERMINAL APPL SPEC | FEED |
|--------------------|------------------|
| - | 11.18 [1.440 IN] |

| TYCO PN | BURNDY PN | | |
|-----------|-----------|---|---|
| 1572834-1 | 21059-02 | - | - |
| 1572835-1 | 21062-02 | - | - |

| WIRE SIZE | CRIMP HEIGHT | PINPN & LENGTH [IN] |
|---------------------|-----------------------------|---------------------|
| 1.50mm ² | 1.57 ±0.05 [1.062 ±.002 IN] | 9-354778-3 [1.2960] |
| 1.00mm ² | 1.34 ±0.05 [1.053 ±.002 IN] | 1-354779-4 [1.3060] |
| 0.50mm ² | 1.11 ±0.05 [1.044 ±.002 IN] | 3-354779-4 [1.3160] |

- △ RECOMMENDED SPARE PARTS.
- 2. GREASE RAM, CAM, CAM FOLLOWER AND FEED ROD LIGHTLY.
- 3. LUBRICATE DAILY PER THE APPLICATOR INSTRUCTION SHEET SUPPLIED WITH THE APPLICATOR.
- △ CUT TO LENGTH ON ASSEMBLY.
- △ ALL CRIMP DATA CALCULATED BY TYCO ELECTRONICS.
- △ 1.50mm² WIRE SIZE WILL NOT MEET TENSILE VALUE TO TYCO ELECTRONICS UK STANDARDS, THEREFORE CANNOT BE RECOMMENDED FOR USE IN THIS TERMINAL.
- △ INSULATION RANGE SHOWN IS THAT OF THE APPLICATOR AND NOT THAT OF THE TERMINAL.

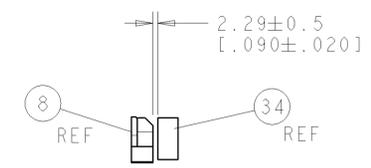
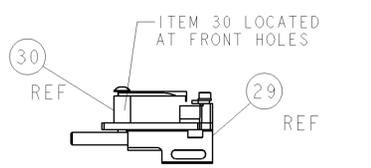
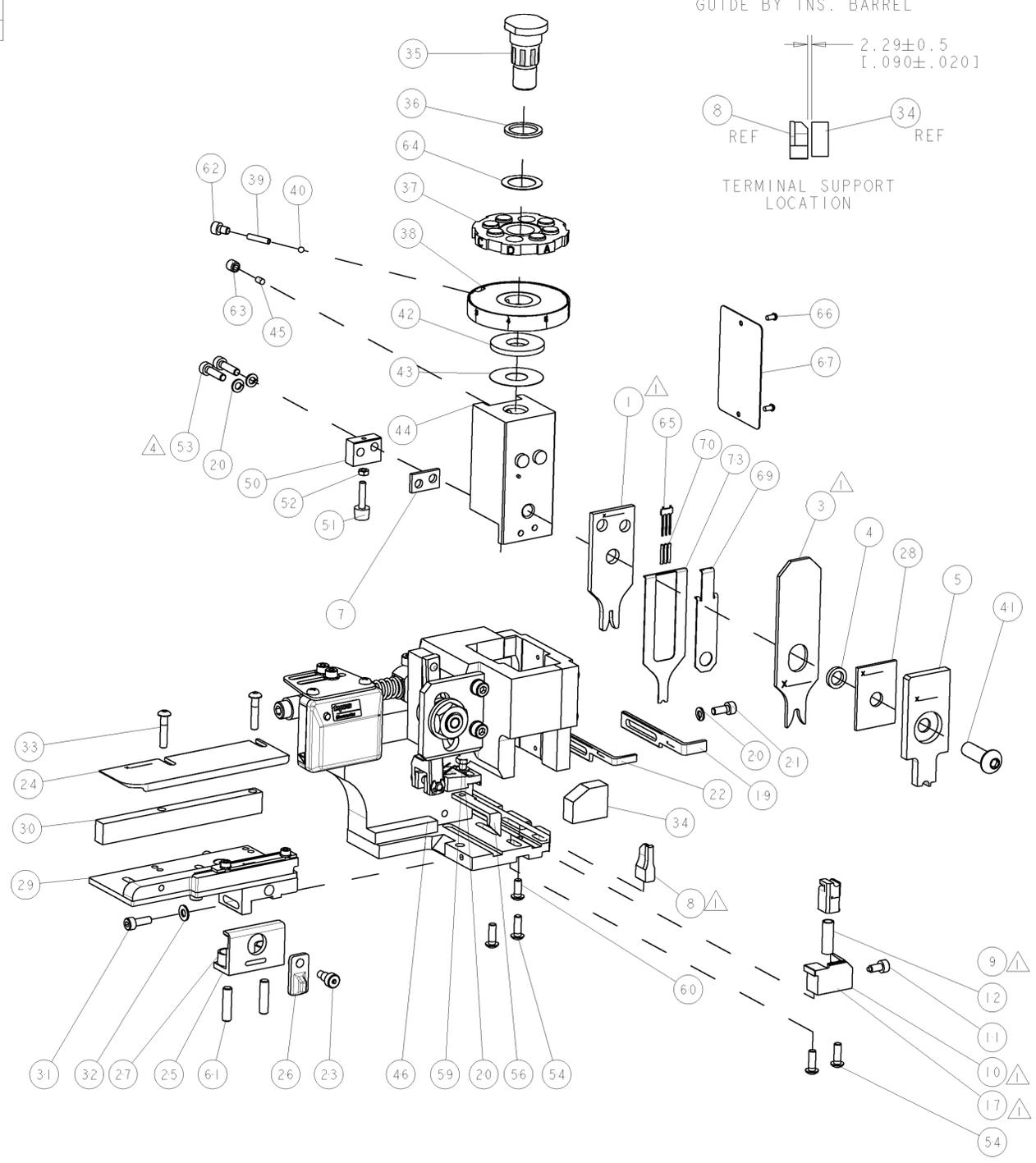
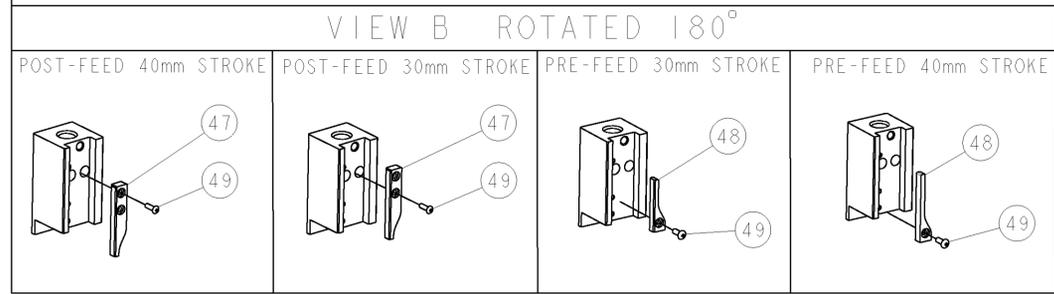

| ITEM NO | DESCRIPTION |
|---------|--|
| 84 | |
| 83 | |
| 82 | |
| 81 | |
| 80 | |
| 79 | |
| 78 | |
| 77 | |
| 76 | |
| 75 | |
| 74 | |
| -77 | -76 -72 -71 -6 -2 -1 PART NO DESCRIPTION ITEM NO |

| SET UP GAGE 458637-3 | | LOC | DIST | REVISIONS | | | |
|----------------------|----|-----|------|-----------|-------------------|-----------|--------|
| A | 66 | | | REV | DATE | BY | APPD |
| | | | | A | SEE ECO-05-014535 | 25NOV2005 | LJL MC |

| ITEM NO | DESCRIPTION | ITEM NO |
|---------|---------------------------------|---------|
| 73 | DEPRESSOR, WIRE | 73 |
| 72 | | 72 |
| 71 | DOCUMENTATION PACKAGE | 71 |
| 70 | SPRING, COMPRESSION | 70 |
| 69 | DEPRESSOR, SPACER | 69 |
| 68 | | 68 |
| 67 | PLATE, IDENTIFICATION | 67 |
| 66 | SCREW, DRIVE | 66 |
| 65 | HOLDER, PIN | 65 |
| 64 | WASHER, FLAT PRECISION | 64 |
| 63 | SCR, SET, CUP POINT M6 X 6.0 | 63 |
| 62 | SCR, SKT HD CAP M4 X 6.0 | 62 |
| 61 | SCR, SET, FLT POINT M5 X 20.0 | 61 |
| 60 | SCR, BTN SKT HD CAP (M4 X 10.0) | 60 |
| 59 | SCR, HEX HD CAP M4 X 8.0 | 59 |
| 58 | | 58 |
| 57 | | 57 |
| 56 | PAWL, FEED | 56 |
| 55 | | 55 |
| 54 | SCR, BTN SKT HD CAP (M4 X 12.0) | 54 |
| 53 | SCR, SKT HD CAP M4 X 16.0 | 53 |
| 52 | NUT, HEX, REG M3 | 52 |
| 51 | BUMPER, HOLD DOWN | 51 |
| 50 | SPACER, TONKER | 50 |
| 49 | SCR, BTN SKT HD CAP (M3 X 10.0) | 49 |
| 48 | CAM, UNIVERSAL PRE FEED | 48 |
| 47 | CAM, UNIVERSAL POST-FEED | 47 |
| 46 | APPLICATOR SUBASSEMBLY, HDI | 46 |
| 45 | PLUG, NYLON | 45 |
| 44 | RAM | 44 |
| 43 | SHIM SUB-ASSY | 43 |
| 42 | WASHER, RAM (.115) | 42 |
| 41 | SCR, BTN SKT HD CAP (M8 X 25.0) | 41 |
| 40 | BALL, STEEL | 40 |
| 39 | SPRING, COMPRESSION | 39 |
| 38 | DISC, ADJUST, INSULATION CRIMP | 38 |
| 37 | WIRE DISC, ASSEMBLY | 37 |
| 36 | SPRING, COMPRESSION | 36 |
| 35 | POST, RAM | 35 |
| 34 | SUPPORT, TERMINAL | 34 |
| 33 | SCR, BTN SKT HD CAP (M4 X 20.0) | 33 |
| 32 | WASHER, FLAT, REG M4 | 32 |
| 31 | SCR, SKT HD CAP M4 X 12.0 | 31 |
| 30 | SPACER, STRIP GUIDE | 30 |
| 29 | STRIP GUIDE ASSEMBLY | 29 |
| 28 | SPACER, CRIMPER | 28 |
| 27 | SPRING, COMPRESSION | 27 |
| 26 | LEVER, DRAG RELEASE | 26 |
| 25 | DRAG, TERMINAL | 25 |
| 24 | PLATE, STRIP GUIDE | 24 |
| 23 | SCR, SKT HD SHLDR 5.0 DIA X 6.0 | 23 |
| 22 | STRIPPER | 22 |
| 21 | SCR, SKT HD CAP M4 X 10.0 | 21 |
| 20 | WASHER, SPRG LOCK, REG M4 | 20 |
| 19 | STRIPPER | 19 |
| 18 | | 18 |
| 17 | SHEAR HOLDER, FRONT | 17 |
| 16 | | 16 |
| 15 | | 15 |
| 14 | | 14 |
| 13 | | 13 |
| 12 | SPRING, COMPRESSION | 12 |
| 11 | STOP, SHEAR | 11 |
| 10 | SHEAR HOLDER, FRONT, CUT | 10 |
| 9 | FLOATING SHEAR, FRONT | 9 |
| 8 | ANVIL, COMBINATION .070 | 8 |
| 7 | SPACER | 7 |
| 6 | | 6 |
| 5 | DEPRESSOR, SHEAR | 5 |
| 4 | BLOCK, CRIMPER SPACER | 4 |
| 3 | CRIMPER, INSUL O | 3 |
| 2 | | 2 |
| 1 | CRIMPER, WIRE PREMIUM | 1 |

| ITEM NO | DESCRIPTION | ITEM NO |
|---------|------------------------------|-------------|
| -77 | -76 -72 -71 -6 -2 -1 PART NO | DESCRIPTION |

| ITEM NO | DESCRIPTION | ITEM NO |
|---------|-------------|---------|
| 84 | | 84 |
| 83 | | 83 |
| 82 | | 82 |
| 81 | | 81 |
| 80 | | 80 |
| 79 | | 79 |
| 78 | | 78 |
| 77 | | 77 |
| 76 | | 76 |
| 75 | | 75 |
| 74 | | 74 |

| ITEM NO | DESCRIPTION | ITEM NO |
|---------|---------------------------------|---------|
| 73 | DEPRESSOR, WIRE | 73 |
| 72 | | 72 |
| 71 | DOCUMENTATION PACKAGE | 71 |
| 70 | SPRING, COMPRESSION | 70 |
| 69 | DEPRESSOR, SPACER | 69 |
| 68 | | 68 |
| 67 | PLATE, IDENTIFICATION | 67 |
| 66 | SCREW, DRIVE | 66 |
| 65 | HOLDER, PIN | 65 |
| 64 | WASHER, FLAT PRECISION | 64 |
| 63 | SCR, SET, CUP POINT M6 X 6.0 | 63 |
| 62 | SCR, SKT HD CAP M4 X 6.0 | 62 |
| 61 | SCR, SET, FLT POINT M5 X 20.0 | 61 |
| 60 | SCR, BTN SKT HD CAP (M4 X 10.0) | 60 |
| 59 | SCR, HEX HD CAP M4 X 8.0 | 59 |
| 58 | | 58 |
| 57 | | 57 |
| 56 | PAWL, FEED | 56 |
| 55 | | 55 |
| 54 | SCR, BTN SKT HD CAP (M4 X 12.0) | 54 |
| 53 | SCR, SKT HD CAP M4 X 16.0 | 53 |
| 52 | NUT, HEX, REG M3 | 52 |
| 51 | BUMPER, HOLD DOWN | 51 |
| 50 | SPACER, TONKER | 50 |
| 49 | SCR, BTN SKT HD CAP (M3 X 10.0) | 49 |
| 48 | CAM, UNIVERSAL PRE FEED | 48 |
| 47 | CAM, UNIVERSAL POST-FEED | 47 |
| 46 | APPLICATOR SUBASSEMBLY, HDI | 46 |
| 45 | PLUG, NYLON | 45 |
| 44 | RAM | 44 |
| 43 | SHIM SUB-ASSY | 43 |
| 42 | WASHER, RAM (.115) | 42 |
| 41 | SCR, BTN SKT HD CAP (M8 X 25.0) | 41 |
| 40 | BALL, STEEL | 40 |
| 39 | SPRING, COMPRESSION | 39 |
| 38 | DISC, ADJUST, INSULATION CRIMP | 38 |
| 37 | WIRE DISC, ASSEMBLY | 37 |
| 36 | SPRING, COMPRESSION | 36 |
| 35 | POST, RAM | 35 |
| 34 | SUPPORT, TERMINAL | 34 |
| 33 | SCR, BTN SKT HD CAP (M4 X 20.0) | 33 |
| 32 | WASHER, FLAT, REG M4 | 32 |
| 31 | SCR, SKT HD CAP M4 X 12.0 | 31 |
| 30 | SPACER, STRIP GUIDE | 30 |
| 29 | STRIP GUIDE ASSEMBLY | 29 |
| 28 | SPACER, CRIMPER | 28 |
| 27 | SPRING, COMPRESSION | 27 |
| 26 | LEVER, DRAG RELEASE | 26 |
| 25 | DRAG, TERMINAL | 25 |
| 24 | PLATE, STRIP GUIDE | 24 |
| 23 | SCR, SKT HD SHLDR 5.0 DIA X 6.0 | 23 |
| 22 | STRIPPER | 22 |
| 21 | SCR, SKT HD CAP M4 X 10.0 | 21 |
| 20 | WASHER, SPRG LOCK, REG M4 | 20 |
| 19 | STRIPPER | 19 |
| 18 | | 18 |
| 17 | SHEAR HOLDER, FRONT | 17 |
| 16 | | 16 |
| 15 | | 15 |
| 14 | | 14 |
| 13 | | 13 |
| 12 | SPRING, COMPRESSION | 12 |
| 11 | STOP, SHEAR | 11 |
| 10 | SHEAR HOLDER, FRONT, CUT | 10 |
| 9 | FLOATING SHEAR, FRONT | 9 |
| 8 | ANVIL, COMBINATION .070 | 8 |
| 7 | SPACER | 7 |
| 6 | | 6 |
| 5 | DEPRESSOR, SHEAR | 5 |
| 4 | BLOCK, CRIMPER SPACER | 4 |
| 3 | CRIMPER, INSUL O | 3 |
| 2 | | 2 |
| 1 | CRIMPER, WIRE PREMIUM | 1 |

| ITEM NO | DESCRIPTION | ITEM NO |
|---------|------------------------------|-------------|
| -77 | -76 -72 -71 -6 -2 -1 PART NO | DESCRIPTION |

| ITEM NO | DESCRIPTION | ITEM NO |
|---------|-------------|---------|
| 84 | | 84 |
| 83 | | 83 |
| 82 | | 82 |
| 81 | | 81 |
| 80 | | 80 |
| 79 | | 79 |
| 78 | | 78 |
| 77 | | 77 |
| 76 | | 76 |
| 75 | | 75 |
| 74 | | 74 |

| ITEM NO | DESCRIPTION | ITEM NO |
|---------|---------------------------------|---------|
| 73 | DEPRESSOR, WIRE | 73 |
| 72 | | 72 |
| 71 | DOCUMENTATION PACKAGE | 71 |
| 70 | SPRING, COMPRESSION | 70 |
| 69 | DEPRESSOR, SPACER | 69 |
| 68 | | 68 |
| 67 | PLATE, IDENTIFICATION | 67 |
| 66 | SCREW, DRIVE | 66 |
| 65 | HOLDER, PIN | 65 |
| 64 | WASHER, FLAT PRECISION | 64 |
| 63 | SCR, SET, CUP POINT M6 X 6.0 | 63 |
| 62 | SCR, SKT HD CAP M4 X 6.0 | 62 |
| 61 | SCR, SET, FLT POINT M5 X 20.0 | 61 |
| 60 | SCR, BTN SKT HD CAP (M4 X 10.0) | 60 |
| 59 | SCR, HEX HD CAP M4 X 8.0 | 59 |
| 58 | | 58 |
| 57 | | 57 |
| 56 | PAWL, FEED | 56 |
| 55 | | 55 |
| 54 | SCR, BTN SKT HD CAP (M4 X 12.0) | 54 |
| 53 | SCR, SKT HD CAP M4 X 16.0 | 53 |
| 52 | NUT, HEX, REG M3 | 52 |
| 51 | BUMPER, HOLD DOWN | 51 |
| 50 | SPACER, TONKER | 50 |
| 49 | SCR, BTN SKT HD CAP (M3 X 10.0) | 49 |
| 48 | CAM, UNIVERSAL PRE FEED | 48 |
| 47 | CAM, UNIVERSAL POST-FEED | 47 |
| 46 | APPLICATOR SUBASSEMBLY, HDI | 46 |
| 45 | PLUG, NYLON | 45 |
| 44 | RAM | 44 |
| 43 | SHIM SUB-ASSY | 43 |
| 42 | WASHER, RAM (.115) | 42 |
| 41 | SCR, BTN SKT HD CAP (M8 X 25.0) | 41 |
| 40 | BALL, STEEL | 40 |
| 39 | SPRING, COMPRESSION | 39 |
| 38 | DISC, ADJUST, INSULATION CRIMP | 38 |
| 37 | WIRE DISC, ASSEMBLY | 37 |
| 36 | SPRING, COMPRESSION | 36 |
| 35 | POST, RAM | 35 |
| 34 | SUPPORT, TERMINAL | 34 |
| 33 | SCR, BTN SKT HD CAP (M4 X 20.0) | 33 |
| 32 | WASHER, FLAT, REG M4 | 32 |
| 31 | SCR, SKT HD CAP M4 X 12.0 | 31 |
| 30 | SPACER, STRIP GUIDE | 30 |
| 29 | STRIP GUIDE ASSEMBLY | 29 |
| 28 | SPACER, CRIMPER | 28 |
| 27 | SPRING, COMPRESSION | 27 |
| 26 | LEVER, DRAG RELEASE | 26 |
| 25 | DRAG, TERMINAL | 25 |
| 24 | PLATE, STRIP GUIDE | 24 |
| 23 | SCR, SKT HD SHLDR 5.0 DIA X 6.0 | 23 |
| 22 | STRIPPER | 22 |
| 21 | SCR, SKT HD CAP M4 X 10.0 | 21 |
| 20 | WASHER, SPRG LOCK, REG M4 | 20 |
| 19 | STRIPPER | 19 |
| 18 | | 18 |
| 17 | SHEAR HOLDER, FRONT | 17 |
| 16 | | 16 |
| 15 | | 15 |
| 14 | | 14 |
| 13 | | 13 |
| 12 | SPRING, COMPRESSION | 12 |
| 11 | STOP, SHEAR | 11 |
| 10 | SHEAR HOLDER, FRONT, CUT | 10 |
| 9 | FLOATING SHEAR, FRONT | 9 |
| 8 | ANVIL, COMBINATION .070 | 8 |
| 7 | SPACER | 7 |
| 6 | | 6 |
| 5 | DEPRESSOR, SHEAR | 5 |
| 4 | BLOCK, CRIMPER SPACER | 4 |
| 3 | CRIMPER, INSUL O | 3 |
| 2 | | 2 |
| 1 | CRIMPER, WIRE PREMIUM | 1 |

| ITEM NO | DESCRIPTION | ITEM NO |
|---------|------------------------------|-------------|
| -77 | -76 -72 -71 -6 -2 -1 PART NO | DESCRIPTION |

| ITEM NO | DESCRIPTION | ITEM NO |
|---------|-------------|---------|
| 84 | | 84 |
| 83 | | 83 |
| 82 | | 82 |
| 81 | | 81 |
| 80 | | 80 |
| 79 | | 79 |
| 78 | | 78 |
| 77 | | 77 |
| 76 | | 76 |
| 75 | | 75 |
| 74 | | 74 |

| ITEM NO | DESCRIPTION | ITEM NO |
|---------|---------------------------------|---------|
| 73 | DEPRESSOR, WIRE | 73 |
| 72 | | 72 |
| 71 | DOCUMENTATION PACKAGE | 71 |
| 70 | SPRING, COMPRESSION | 70 |
| 69 | DEPRESSOR, SPACER | 69 |
| 68 | | 68 |
| 67 | PLATE, IDENTIFICATION | 67 |
| 66 | SCREW, DRIVE | 66 |
| 65 | HOLDER, PIN | 65 |
| 64 | WASHER, FLAT PRECISION | 64 |
| 63 | SCR, SET, CUP POINT M6 X 6.0 | 63 |
| 62 | SCR, SKT HD CAP M4 X 6.0 | 62 |
| 61 | SCR, SET, FLT POINT M5 X 20.0 | 61 |
| 60 | SCR, BTN SKT HD CAP (M4 X 10.0) | 60 |
| 59 | SCR, HEX HD CAP M4 X 8.0 | 59 |
| 58 | | 58 |
| 57 | | 57 |
| 56 | PAWL, FEED | 56 |
| 55 | | 55 |
| 54 | SCR, BTN SKT HD CAP (M4 X 12.0) | 54 |
| 53 | SCR, SKT HD CAP M4 X 16.0 | 53 |
| 52 | NUT, HEX, REG M3 | 52 |
| 51 | BUMPER, HOLD DOWN | 51 |
| 50 | SPACER, TONKER | 50 |
| 49 | SCR, BTN SKT HD CAP (M3 X 10.0) | 49 |