

REAL TIME CLOCK MODULE (I²C-Bus)

Low current consumption

RTC - 8564 JE / NB RX - 8564 LC

- Built in frequency adjusted 32.768 kHz crystal unit.
- Interface Type : I²C-Bus Interface (400 kHz)
- Operating voltage range 1.8 : V to 5.5 V
- Timekeeper voltage range 1.0 : V to 5.5 V / -20 °C to +70 °C
- Low backup current 275 : nA / 3.0 V(Typ.)
- 32.768 kHz frequency output function : C-MOS output With Control Pin
- The various functions include full calendar, alarm, timer, and power supply voltage monitoring function

* The I²C-Bus is a trademark of NXP Semiconductors



Product Number (Please contact us)
 RTC-8564JE : Q41856471000100
 RTC-8564NB : Q41856491000200
 RX-8564LC : Q418564C2000100



Actual size



Block diagram

Overview

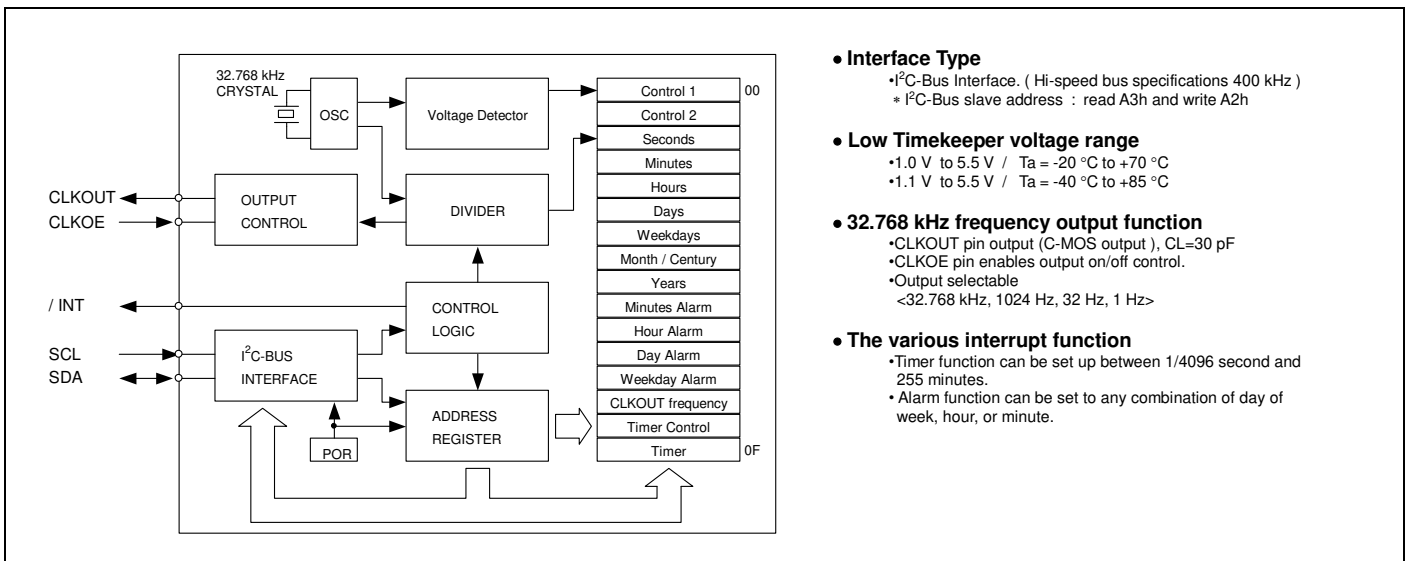

Interface Type

- I²C-Bus Interface. (Hi-speed bus specifications 400 kHz)
- * I²C-Bus slave address : read A3h and write A2h

Low Timekeeper voltage range

- 1.0 V to 5.5 V / Ta = -20 °C to +70 °C
- 1.1 V to 5.5 V / Ta = -40 °C to +85 °C

32.768 kHz frequency output function

- CLKOUT pin output (C-MOS output), CL=30 pF
- CLKOE pin enables output on/off control.
- Output selectable
 <32.768 kHz, 1024 Hz, 32 Hz, 1 Hz>

The various interrupt function

- Timer function can be set up between 1/4096 second and 255 minutes.
- Alarm function can be set to any combination of day of week, hour, or minute.

Pin Function

Terminal connection / External dimensions

(Unit:mm)

Signal Name	Input/Output	Function															
SCL	Input	Serial clock input pin.															
SDA	Bi-directional	Data input and output pin.															
CLKOUT	Output	32.768 kHz clock output pin with the output control function. (C-MOS) CLKOE pin control the condition of CLKOUT with FE-bit, etc.															
CLKOE	Input	<table border="1"> <thead> <tr> <th>CLKOE pin input</th> <th>FE bit</th> <th>CLKOUT pin output</th> </tr> </thead> <tbody> <tr> <td>HIGH</td> <td>1</td> <td>Output (C-MOS)</td> </tr> <tr> <td>LOW</td> <td>0</td> <td>OFF (LOW)</td> </tr> <tr> <td>LOW</td> <td>1</td> <td>OFF (LOW)</td> </tr> <tr> <td>LOW</td> <td>0</td> <td>OFF (LOW)</td> </tr> </tbody> </table>	CLKOE pin input	FE bit	CLKOUT pin output	HIGH	1	Output (C-MOS)	LOW	0	OFF (LOW)	LOW	1	OFF (LOW)	LOW	0	OFF (LOW)
CLKOE pin input	FE bit	CLKOUT pin output															
HIGH	1	Output (C-MOS)															
LOW	0	OFF (LOW)															
LOW	1	OFF (LOW)															
LOW	0	OFF (LOW)															
/INT	Output	Interrupt output (N-ch open drain)															
VDD	—	Connected to a positive power supply.															
GND	—	Connected to a ground.															

RTC - 8564 JE

VSOJ - 20 pin

RTC - 8564 NB

SON - 22 pin

RX - 8564 LC

VSOJ - 12pin

The metal case inside of the molding compound may be exposed on the top or bottom of this product. This purely cosmetic and does not have any effect on quality, reliability or electrical specs.

***Stop using the glue**
 Any glue must never use it after soldering LC-package to a circuit board. This product has glass on the back side of a package. When glue invasions between circuit board side and glass side, then glass cracks by thermal expansion of glue. In this case a crystal oscillation stops. Consider glue abolition or glue do not touch to LC-package

Specifications (characteristics)

* Refer to application manual for details.

Recommended Operating Conditions

Item	Symbol	Conditions	Min.	Typ.	Max.	Unit
Power voltage	VDD	—	1.8	3.0	5.5	V
Clock voltage	VCLK	—	VLOW	3.0	5.5	V
Operating temperature	TOPR	—	-40	+25	+85	°C

Low voltage detection

Item	Symbol	Conditions	Typ.	Max.	Unit	
Low voltage detection	VLOW	JE, NB	Ta = -20 °C ~ +70 °C	0.9	1.0	V
			Ta = -40 °C ~ +85 °C	0.9	1.1	V
		LC	Ta = -20 °C ~ +70 °C	0.9	1.2	V
			Ta = -40 °C ~ +85 °C	0.9	1.3	V

Frequency characteristics

Item	Symbol	Conditions	Rating	Unit
Frequency tolerance	Δf/f	Ta = +25 °C VDD = 3.0 V	B: 5 ± 23 *	× 10 ⁻⁶

* Please ask for tighter tolerance. (Equivalent to ±1 minute of monthly deviation)

Current consumption characteristics

Ta = -40 °C to +85 °C

Item	Symbol	Conditions	Min.	Typ.	Max.	Unit	
Current Consumption	I _{bk}	f _{SCL} = 0 Hz CLKOE = GND CLKOUT ; output OFF (LOW)	VDD = 5 V	-	330	800	nA
			VDD = 3 V	-	275	700	
	I _{s2k}	f _{SCL} = 0 Hz CLKOE = VDD CLKOUT ; 32.768 kHz output ON (Output=OPEN ; CL = 0 pF)	VDD = 5 V	-	2.5	3.4	μA
			VDD = 3 V	-	1.5	2.2	

PROMOTION OF ENVIRONMENTAL MANAGEMENT SYSTEM CONFORMING TO INTERNATIONAL STANDARDS

At Seiko Epson, all environmental initiatives operate under the Plan-Do-Check-Action (PDCA) cycle designed to achieve continuous improvements. The environmental management system (EMS) operates under the ISO 14001 environmental management standard.

All of our major manufacturing and non-manufacturing sites, in Japan and overseas, completed the acquisition of ISO 14001 certification.

ISO 14000 is an international standard for environmental management that was established by the International Standards Organization in 1996 against the background of growing concern regarding global warming, destruction of the ozone layer, and global deforestation.





WORKING FOR HIGH QUALITY

In order provide high quality and reliable products and services than meet customer needs,

Seiko Epson made early efforts towards obtaining ISO9000 series certification and has acquired ISO9001 for all business establishments in Japan and abroad. We have also acquired ISO/TS 16949 certification that is requested strongly by major automotive manufacturers as standard.

ISO/TS16949 is the international standard that added the sector-specific supplemental requirements for automotive industry based on ISO9001.

► Explanation of the mark that are using it for the catalog

	► Pb free.
	► Complies with EU RoHS directive. *About the products without the Pb-free mark. Contains Pb in products exempted by EU RoHS directive. (Contains Pb in sealing glass, high melting temperature type solder or other.)
	► Designed for automotive applications such as Car Multimedia, Body Electronics, Remote Keyless Entry etc.
	► Designed for automotive applications related to driving safety (Engine Control Unit, Air Bag, ESC etc).

Notice

- This material is subject to change without notice.
- Any part of this material may not be reproduced or duplicated in any form or any means without the written permission of Seiko Epson.
- The information about applied data, circuitry, software, usage, etc. written in this material is intended for reference only. Seiko Epson does not assume any liability for the occurrence of customer damage or infringing on any patent or copyright of a third party. This material does not authorize the licensing for any patent or intellectual copyrights.
- When exporting the products or technology described in this material, you should comply with the applicable export control laws and regulations and follow the procedures required by such laws and regulations.
- You are requested not to use the products (and any technical information furnished, if any) for the development and/or manufacture of weapon of mass destruction or for other military purposes. You are also requested that you would not make the products available to any third party who may use the products for such prohibited purposes.
- These products are intended for general use in electronic equipment. When using them in specific applications that require extremely high reliability, such as the applications stated below, you must obtain permission from Seiko Epson in advance.
/ Space equipment (artificial satellites, rockets, etc.) / Transportation vehicles and related (automobiles, aircraft, trains, vessels, etc.) / Medical instruments to sustain life / Submarine transmitters / Power stations and related / Fire work equipment and security equipment / traffic control equipment / and others requiring equivalent reliability.
- All brands or product names mentioned herein are trademarks and/or registered trademarks of their respective.