

VPX283UC320

Overview

3U VPX DC-DC Power Converter Card
 28Vdc Input, 6 Outputs
 320W Max Combined Output

Market(s)

Military, Aviation, Embedded Computing

Typical Application(s)

Electronics Equipment Rack



Product Highlights

This single slot thin (5HP) filtered 28Vdc VPX283UC320 power card with six outputs at 320W maximum power, is a COTS military power supply solution designed to meet applicable portions of MIL-STD-810F vibration and shock requirements and applicable portions of MIL-STD-461E EMI requirements. The VPX283UC320 features high efficiency (up to 90%), high power (up to 320W), and option for IPMI I2C interface. It also has alignment keys that offer keying options when using multiple power supplies in one chassis.

Features

- 28Vdc per MIL-STD-704F
- 6 Output Voltages, 320W
- Single Slot VPX Power Card
- MIL-STD-461G EMI *
- VITA 46.11 IPMI available

* Designed to meet applicable portions of this standard. Contact Aegis Power Systems, Inc. for specific details.

Table 1: Maximum Continuous Operating Ratings

Parameter	Rating	Unit	Notes
Vin max range	18 to 36	Vdc	28Vdc Nominal
Temperature	-40 to +85	°C	Baseplate @ wedgelocks *85C @ 320W total output
Input power	364	W	@ 320W out (28VDC input)
Combined output power	320	W	See Table 2 for DC output variations
Efficiency	88	%	Typical @ nominal conditions

About Us

Aegis Power Systems, Inc. specializes in the design, development, and manufacture of AC-DC and DC-DC power supplies for high-performance, rugged, critical, and specialty applications. Markets served include defense, industrial, communications, aircraft, shipboard, rack mount, embedded computing, and electric vehicle applications.

[Contact us](#) to find out if this item can be configured or redesigned to meet your specific technology need.

SPECIFICATIONS

(Typical at 25°C, nominal line and 100% load, unless otherwise specified.)

Parameter	Notes
Input Voltage	Designed to meet MIL-STD-704F Table IV (DC Normal Operation) 22Vdc to 29Vdc, 28 Vdc nominal, continuous operation during Figure 13 (Normal DC voltage transients) 50 Vdc max.
Input Current	16.5A max @ 22Vdc, 13A typical @ 28Vdc input (320W out).
Input Power	364W max @ 320W out.
Total Output Power	320W max. all outputs combined.
Output Voltages	(see table 2).
Efficiency	86% minimum, 88% typical, 90% max.
Start-Up Time	2 second maximum.
Voltage Set Point	+/- 5% V Out nominal (for any combination).
Line/Load Regulation	+/- 5% V Out nominal (for any combination).
Output Ripple	50mVpk-pk Max. (20 MHz BW) all except; +/-12 Vdc 100mVpk-pk Max.
Current Limit	Short circuit protected with automatic recovery (110% - 130% of rated output).
Temperature	-40°C to +85°C Operating baseplate @ 320W output. (+85°C Operating baseplate @ 320W output) -40°C to +125°C Storage.
Cooling	Conduction cooling through wedgelocks to customer rack.
Package	Single slot pluggable slide in rack card.
Dimensions	3U x 5hp x 168.49mm (see mechanical drawing page).
Weight	1.45 lbs. (typical).
Connectors	1ea TE Connectivity 6450849-7 or equivalent (see Table 4).
Vibration	Designed to meet – ANSI/VITA 47-2005 (R2007), Section 4.4.3 Vibration Class V3. MIL-STD-810F, Method 514.5, Procedure I.
Shock:	Designed to meet - ANSI/VITA 47-2005 (R2007), Section 4.5.2 Operating Shock Class OS2 ANSI/VITA 47-2005 (R2007), Section 4.5.3 Bench Handling Shock. MIL-STD-810F, Method 516.5, Procedure I.
Humidity	0 – 95% non-condensing per ANSI/VITA 47-2005 (R2007), Section 4.6 Humidity.
EMI	Designed to meet MIL-STD-461G conducted emissions, when coupled with a front end filter that provides at least 80 dB of attenuation for frequencies greater than 10 kHz.
System Management	VITA 46.11 IPMI I2C interface with monitoring available. <i>See Table 2 for options.</i>

Specifications subject to change without notice.

Table 2: Voltage Output (Nominal), IPMI Interface, and Temperature Options

VPX283UC320-XX	VS1	VS2	VS3	VS4	VS5	VS6
VPX283UC320-01	+12VDC @ 300W	+3.3VDC @ 100W	+5VDC @ 75W	-12VDC_AUX @ 18W	3.3VDC_AUX @ 10W	+12VDC_AUX @ 18W
	No IPMI. -40C to +85C operational and -40C to +125C storage.					
VPX283UC320-02	Same outputs as -01 version. Includes IPMI interface. -40C to +85C operational and -40C to +125C storage.					
VPX283UC320-03	Same outputs as -01 version. No IPMI interface. -40C to +85C operational and -55C to +125C storage.					
VPX283UC320-04	Same outputs as -01 version. Includes IPMI interface. -40C to +85C operational and -55C to +125C storage.					

NOTES:

1. VS1-VS6 output power levels indicate maximum power available per output. Total combined power of all outputs on VPX283UC320 cannot exceed 320W @ 85°C
 2. Temperature measured on the unit's baseplate @ wedge locks
 3. VITA 46.11 IPMI I2C interface provides:
 - (VS1-VS6) Output Voltage / (VS1-VS3) Current monitoring
 - On-board temperature monitoring
 - Power good status, PSU serial number & revision
 - Dynamic addressing (GA0 & GA1) allows up to four supplies on same I2C bus
- * (contact for more details)

Table 3: ENABLE / INHIBIT

Control Inputs		Power Outputs	
ENABLE	INHIBIT	3.3V_AUX	PO1, PO2, PO3, +12V_AUX, and -12V_AUX
High	High	Off	Off
High	Low	Off	Off
Low	High	On	On
Low	Low	On	Off

Table 4: Connector Specifications

TE Connectivity Connector 6450849-7 or equivalent

Contact Designation		Conductor Circuit
P1	40A	-DC_IN/ACN
P2	40A	+DC_IN/ACL
LP1	20A	CHASSIS
A1	<1A	(NC)
B1	<1A	(NC)
C1	<1A	(NC)
D1	<1A	(NC)
A2	<1A	(NC)
B2	<1A	FAIL*
C2	<1A	INHIBIT*
D2	<1A	ENABLE*
A3	<1A	(NC)
B3	<1.5A	+12V_AUX (VS6)
C3	<1A	(NC)
D3	<1A	(NC)
A4	<1.5A	3.3V_AUX (VS5)
B4	<1.5A	3.3V_AUX (VS5)
C4	<1.5A	3.3V_AUX (VS5)
D4	<1.5A	3.3V_AUX (VS5)
A5	<1A	GA0
B5	<1A	GA1
C5	<1A	SM0 (I2C/SCL)
D5	<1A	SM1 (I2C/SDA)
A6	<1A	(NC)
B6	<1A	(NC)
C6	<1.5A	-12V_AUX (VS4)
D6	<1A	SYSRESET*
A7	<1A	(NC)
B7	<1A	(NC)
C7	<1A	(NC)
D7	<1A	SIGNAL_RETURN (Common)
A8	<1A	PO1_SENSE
B8	<1A	PO2_SENSE
C8	<1A	PO3_SENSE
D8	<1A	SENSE_RETURN (Common)
P3	40A	PO3 (VS3)
P4	40A	POWER_RETURN (Common)
P5	40A	POWER_RETURN (Common)
LP2	20A	PO2 (VS2)
P6	40A	PO1 (VS1)

* Use of a trailing asterisk indicate a logic signal which is active when at the less positive level of its allowable range.

Table 5: IPMI Commands

The following three VITA 46.11 IPMI commands are currently implemented in firmware:

- Get Device ID Command (App (06h) (01h))**
 This command will return the hardware revision, firmware/software revision, command interface revision, system serial number for the power supply.
- Get Self-Test Results Command (App (06h) (04h))**
 This command will initiate the power supply to verify all available sensor readings are within specified operating ranges. It will report successful if there are no errors, or it will report the sensor that was out of range.
- Get Sensor Reading Command (S/E (04h) (2Dh))**
 This command will return the data from one of the available sensors. The following sensors are available:

Self-test Sensor Threshold	Sensor Number	Available Data Sensors	Data Reply Format
OT = 90C	00h	BASEPLATE TEMPERATURE	2 BYTE HEX
OV/UV = +/-5%	01h	VS1 OUTPUT VOLTAGE	2 BYTE HEX
OV/UV = +/-5%	02h	VS2 OUTPUT VOLTAGE	2 BYTE HEX
OV/UV = +/-5%	03h	VS3 OUTPUT VOLTAGE	2 BYTE HEX
OV/UV = +/-5%	04h	VS4 OUTPUT VOLTAGE	2 BYTE HEX
OV/UV = +/-5%	05h	VS5 OUTPUT VOLTAGE	2 BYTE HEX
OV/UV = +/-5%	06h	VS6 OUTPUT VOLTAGE	2 BYTE HEX
OC = 120% Nom.	07h	VS1 OUTPUT CURRENT	2 BYTE HEX
OC = 120% Nom.	08h	VS2 OUTPUT CURRENT	2 BYTE HEX
OC = 120% Nom.	09h	VS3 OUTPUT CURRENT	2 BYTE HEX
N/A	0Ah	TURN-ON COUNTER	2 BYTE HEX

Table 6: Power Derating

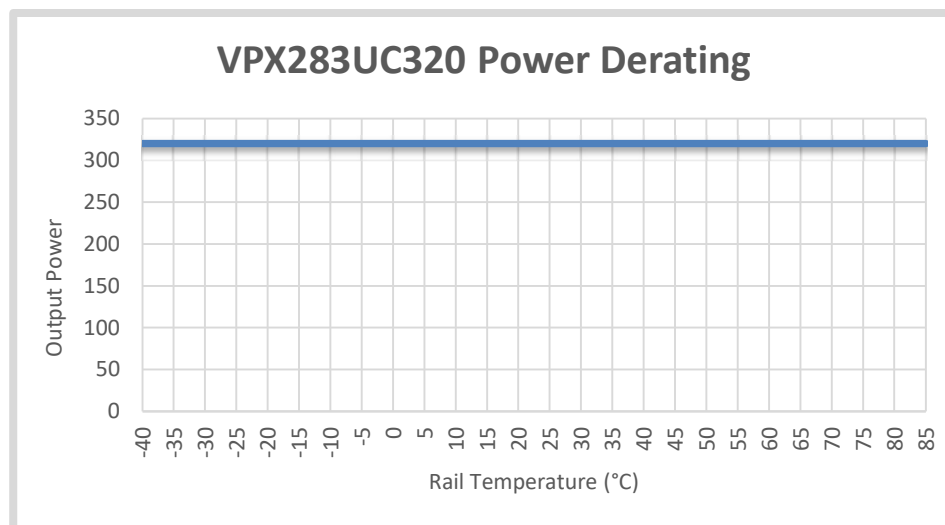

DWG NO.		2		SH	REV
REVISIONS					
ZONE	REV	DATE		APPROVED	
	A01	INITIAL RELEASE		DD/MM/YY	XX

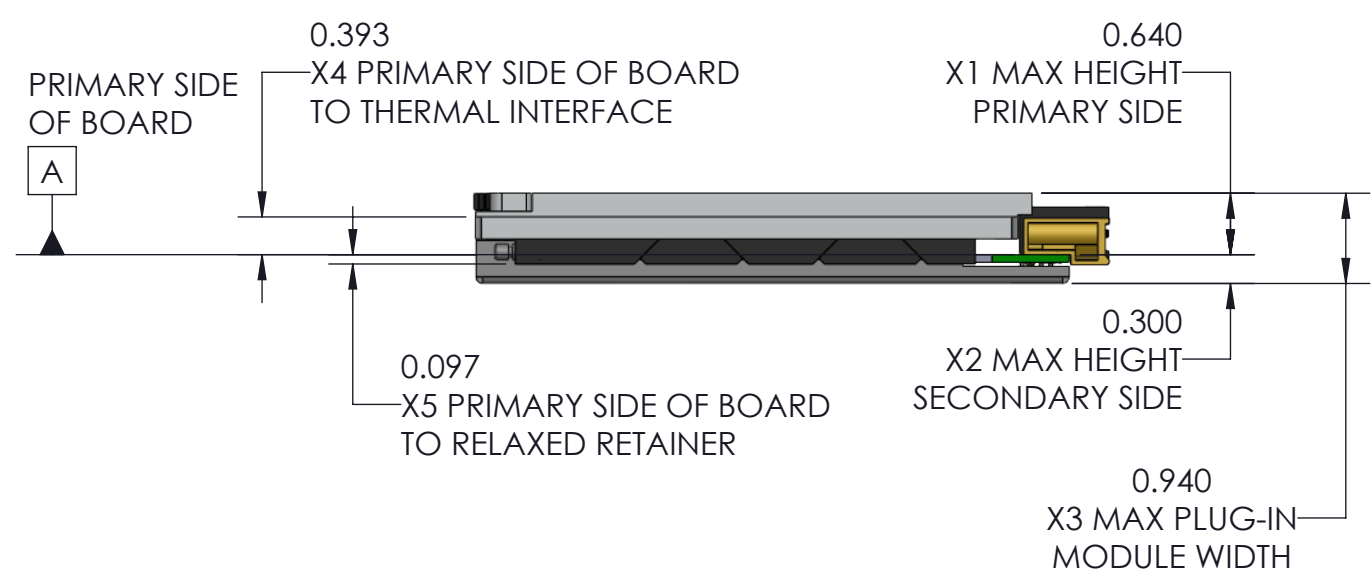
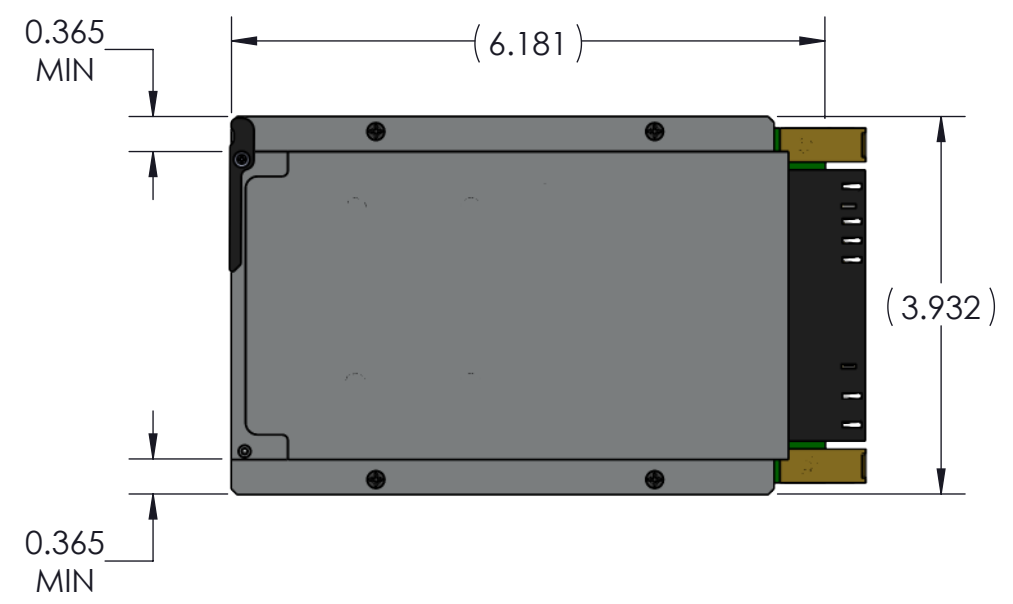

AEGIS POWER SYTEMS, INC. PROPRIETARY INFORMATION. NODISCLOSURE, REPRODUCTION, OR USE OF ANY PARTY HERE OF MAY BE MADE EXECEPT BY EXPRESS WRITTEN PERMISSION OF AEGIS POWER SYTEM, INC.

UNLESS OTHERWISE SPECIFIED:
 DIMENSIONS ARE IN INCHES
 TOLERANCES:
 FRACTIONAL ± N/A
 DEGREES: ± .5
 TWO PLACE DECIMAL ± .02
 THREE PLACE DECIMAL ± .005

CONTRACT NO.		
APPROVALS	NAME	DATE
DRAWN		
CHECKED		
ENG APPR.		
MFG APPR.	RP	
Q.A.	MH	

**AEGIS POWER SYSTEMS
MURPHY, NORTH CAROLINA**

TITLE:
VPXxx3UCxx-
 AEGIS P/N: VPXxx3UCxx-

MATERIAL: SEE NOTE 3
 FINISH: SEE NOTE 4
 DO NOT SCALE DRAWING

COMMENTS:
 GENERATED:BY SOLIDWORKS

SIZE	FSCM NO.	DWG. NO.	REV
B	06ES8	VPXxx3UCxx	
SCALE: 1:2		SHEET 1 OF 1	