

THIS DOCUMENT IS THE PROPERTY OF  
KEYSTONE ELECTRONICS CORP. AND  
SHALL NOT BE REPRODUCED, DISTRIBUTED  
OR USED AS A BASIS FOR MANUFACTURE  
WITHOUT PRIOR WRITTEN PERMISSION  
FROM KEYSTONE ELECTRONICS CORP.

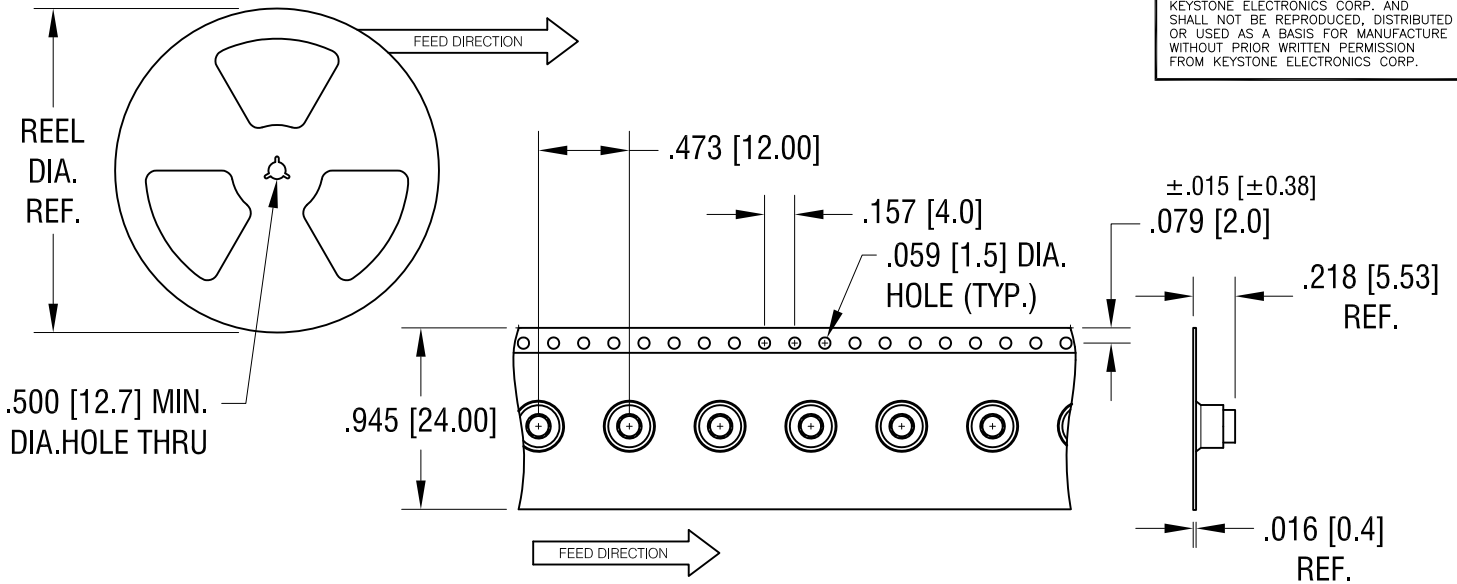

**MOUNTING DETAIL**

**ACTUAL SIZE**

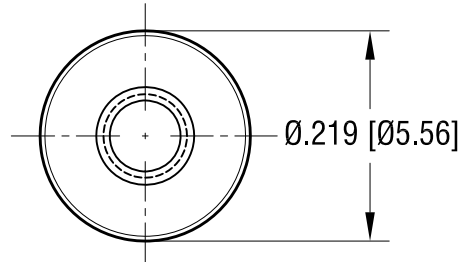
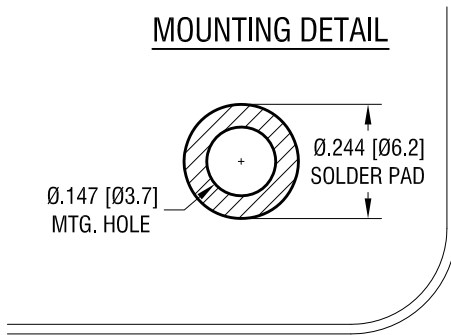

2-56 THD

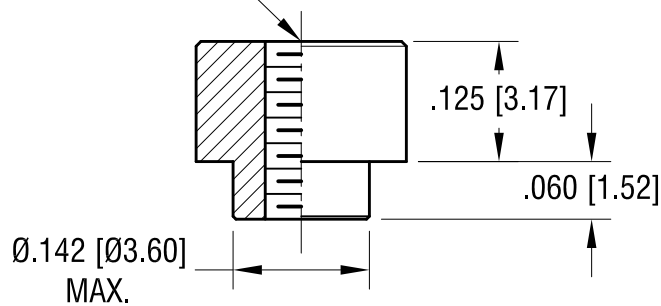

**NOTES:**

1. SUPPLIED ON TAPE AND REEL ONLY.  
TAPE AND REEL SPECIFICATIONS:
2. TAPE:  
MAT'L - ALL CONDUCTIVE POLYSTYRENE CARRIER  
ANSI/EIA-481 STANDARD
3. REEL:  
13" [330.2] DIA. 1000 PIECES PER REEL
4. KAPTON TAPE ADDED TO TOP SURFACE  
OF STANDOFF

<b>KEYSTONE ELECTRONICS CORP.</b>			
www.keyelco.com • NEW HYDE PARK, NY 11040 • Tel (516) 328-7500			
PART NAME		SM STANDOFF	
MATERIAL		STEEL	
FINISH	DRN BY	DATE	
MATTE TIN PLATE	NT	11.09.20	
	APP'D	SCALE	
	LN	5X, 1X	
TOLERANCES	INCH	[MM]	CODE
DECIMAL	± .005	[± 0.13]	C
ANGULAR	± 1°		DWG NO.
UNLESS OTHERWISE SPECIFIED			<b>4872</b>

DATE	DESCRIPTION	REV.	
------	-------------	------	--