

PPC3-EVM-MB User's Guide

Contents

1	Description	2
2	Specifications	2
3	Software	2
4	Supply Setup	3
5	Control Header	4
6	Differential to Single Ended Filter	7
7	PPC3-EVM-MB Schematics	9
8	PPC3-EVM-MB Layer Plots	19
9	PPC3-EVM-MB BOM	29

List of Figures

1	Request PPC3 Access (TAS2770 for Example).....	3
2	EVM Supply Setup	3
3	USB Control Test Setup	3
4	Control Header	4
5	IOVDD Setup.....	4
6	EVM Signals.....	5
7	Alternative Header J3	5
8	Daisy Chain Connection	7
9	Differential to Single Ended Filter.....	7
10	EVM Filter Setup.....	8
11	Schematic 1	9
12	Schematic 2.....	10
13	Schematic 3.....	11
14	Schematic 4.....	12
15	Schematic 5.....	13
16	Schematic 6.....	14
17	Schematic 7.....	15
18	Schematic 8.....	16
19	Schematic 9.....	17
20	Schematic 10	18
21	PPC3-EVM-MB Top Assembly	19
22	PPC3-EVM-MB Top Silk Screen	20
23	PPC3-EVM-MB Top Solder	21
24	PPC3-EVM-MB Top Copper	22
25	PPC3-EVM-MB Copper Layer 2	23
26	PPC3-EVM-MB Copper Layer 3	24
27	PPC3-EVM-MB Bottom Copper	25
28	PPC3-EVM-MB Bottom Solder	26
29	PPC3-EVM-MB Bottom Silk Screen	27

30	PPC3-EVM-MB Bottom Assembly	28
----	-----------------------------------	----

List of Tables

1	PPC3-EVM-MB Requirements	2
2	Jumper Functions.....	4
3	Supported Inputs.....	5
4	PPC3-EVM-MB BOM	29

Trademarks

PurePath is a trademark of Texas Instruments.
 Microsoft, Windows are trademarks of Microsoft Corporation.

1 Description

The PPC3-EVM-MB is designed as a mother board platform for Low Power Audio devices. It features a USB interface that pairs with the PurePath™ Console 3 software. The board is also highly configurable to allow for a variety of digital inputs at both 1.8V and 3.3 V logic levels. The typical daughter card EVM paired with PPC3-EVM-MB will be in a stereo configuration, but this design also can be connected to a second board allowing for an increased channel count.

This EVM includes:

- USB Interface
- Software control via PurePath™ Console 3 (PPC 3) GUI, USB-HID
- USB-class audio device, compatible with Microsoft™ Windows™ 7+
- External 100 - mil headers
- PSIA - I2S/TDM interface
- I2C
- Hardware Shutdown Control
- Interrupt Output

2 Specifications

[Table 1](#) lists the supply, input, and output requirements for PPC3-EVM-MB

Table 1. PPC3-EVM-MB Requirements

Supply Voltage – VBAT	4.5 to 26 V
VCC – I2C	1.8 or 3.3 V
VCC – I2S	1.8 or 3.3 V
IOVDD	1.8 or 3.3 V
± 15 V	± 18 V ABS MAX
USB, USB class-audio	Micro-USB B

NOTE: PPC3-EVM-MB supports a VBAT range from 4.5 to 26 V. When testing a VBAT voltage below 4.5 V it is recommended to remove the VBAT jumper on the EVM and to apply this voltage directly with a separate supply from PPC3-EVM-MB

Please also refer to the user's guide for the specific daughter card EVM installed on PPC3-EVM-MB. VBAT is passed directly to this board through J7. Do not power VBAT beyond the specified rating of the installed daughter card.

3 Software

The PPC3-EVM-MB is intended to be used with the PPC3 software. To request access to the software first request a myTI.com account [here](#).

After creating an account, navigate to the product page for the EVM daughter card that is used and follow the link in the information box to request access to the software.

To request access to PurePath™ Console 3 and other design resources: [Request TAS2770](#)

Figure 1. Request PPC3 Access (TAS2770 for Example)

4 Supply Setup

For most operations, only a single supply is required to power PPC3-EVM-MB. This supply voltage can range from 4.5 V to 26 V and should be applied at J12 or J11 as shown in Figure 2. This will generate onboard 5 V, 3.3 V, and 1.8 V rails and provides these voltages to the connected daughter card.

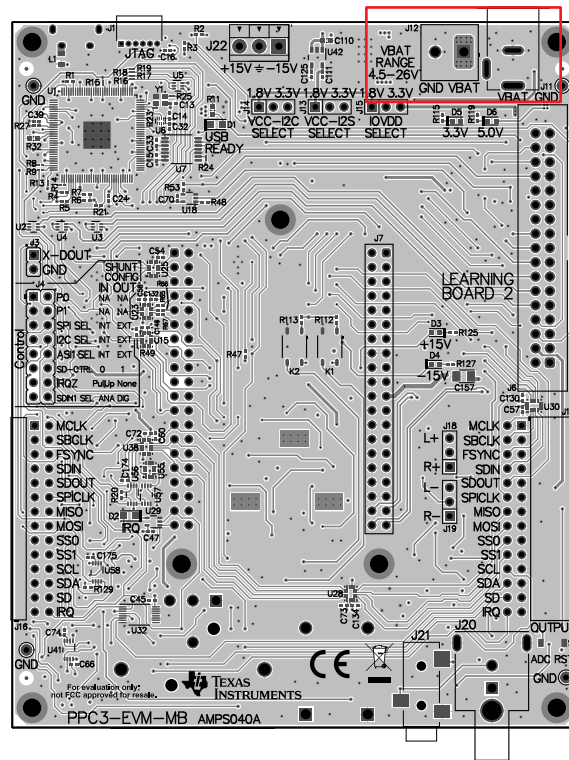

Figure 2. EVM Supply Setup

To ensure proper operation, PPC3-EVM-MB requires that the logic levels of both source signals and daughter card be selected. VCC-I2S sets the logic levels of incoming I2S/TDM signals. VCC-I2C sets the logic levels of SPI, I²C, Interrupt and Shutdown Signals. IOVDD forces PPC3-EVM-MB to translate all of the preceding signals to the operating logic level of the daughter card.

NOTE: The XMOS operates exclusively at 3.3 V. When testing via USB controls, both VCC-I2S and VCC-I2C must be set to 3.3 V as shown in Figure 3.

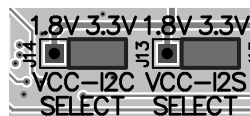

Figure 3. USB Control Test Setup

5 Control Header

The control header is pictured in [Figure 4](#). [Table 2](#) describes the function of each jumper setting

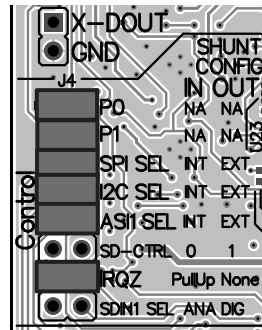

Figure 4. Control Header

Table 2. Jumper Functions

Jumper	Description	Default setting
P0	Development Multiplex Control	Inserted
P1	Development Multiplex Control	Inserted
SPI Sel	Insert = USB, Remove = External Header	Inserted
I2C Sel	Insert = USB, Remove = External Header	Inserted
ASI1 Sel	Insert = USB, Remove = External Header	Inserted
SD Ctrl	Insert = Pull Down or External Control, Remove = Pull Up or XMOS Control	Removed
IRQZ	Insert = Pull Up, Remove = Hi-Z	Inserted
SDIN1 Sel	Insert = Analog Test Mode, Remove = Digital USB	Removed

5.1 USB Control

When installing PPC3 the Texas Instruments Audio Control Panel will also be installed along with the necessary driver to control the PPC-EVM-MB. This allows PPC3 to generate I²C commands via USB and allows Windows to send audio. It is necessary to set hardware jumpers to select this input source. Use the following steps to enable this mode:

- Set VCC-I2C to 3.3 V
- Set VCC-I2S to 3.3V
- Set IOVDD to match test device configuration as shown in [Figure 5](#)

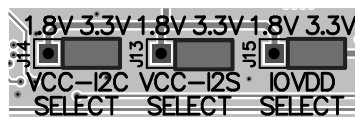

Figure 5. IOVDD Setup

- Set Control Jumpers to default settings shown in [Table 2](#)
- Connect Micro USB from PC to PPC3-EVM-MB
- Connect 4.5 to 26 V supply to J11 or J12

NOTE: PPC3- EVM-MB may accept voltages in excess of the rated voltage of the daughter card in use. The user's guide or product datasheet for the device under test must be checked for maximum input range.

- Check Windows Sound Settings and set to default device
 - Right click on sound icon in system tray
 - Select playback devices
 - Right click on TI-USB Audio UAC 2.0
 - Select Set as Default Device
- Open PPC3 software and connect to product specific plug-in.

5.2 External Inputs

External Input sources including SPI, I²C, and I2S/TDM busses can be provided from an external source. The supported inputs are show in [Table 3](#):

Table 3. Supported Inputs

Input Logic Level	Device Logic Level	Supported Busses
3.3 V	3.3 v	SPI, I2S/TDM, I2C
3.3 V	1.8 V	SPI, I2S/TDM, I2C
1.8 V	3.3 V	SPI, I2S/TDM
1.8 V	1.8 V	SPI, I2S/TDM, I2C

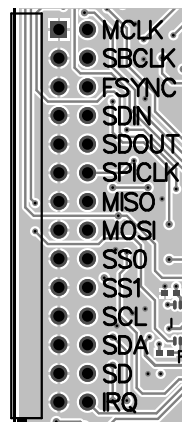

Figure 6. EVM Signals

5.2.1 External I2S/TDM

To set the PPC3-EVM-MB for external I2S/TDM bus, please follow the steps below:

- Remove power from PPC3-EVM-MB
- Set the VCC-I2S Select jumper to match the logic level of the user supplied signal as shown in [Figure 6](#)
- Set the IOVDD Select jumper to match the operating logic level of the test device as shown in [Figure 6](#)
- Remove the AS1 SEL jumper from the control header shown in [Figure 6](#)
- Connect MCLK, SBCLK, FSYNC, and SDIN signals from user external source to J16
 - Some devices may not require MCLK
 - J16 - SDOUT will be driven at IOVDD levels. J3 is available as an alternative header as shown in [Figure 7](#) and will always allow the user to sample SDOUT at 3.3 V.

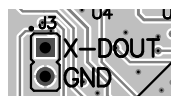

Figure 7. Alternative Header J3

- Power PPC3-EVM-MB and configure device

5.2.2 External I²C

To set the PPC3-EVM-MB for external I²C bus, please follow the steps below:

- Remove power from PPC3-EVM-MB
- Set the VCC-I2C Select jumper to match the logic level of the user supplied signal as shown in [Figure 6](#)
- Set the IOVDD Select jumper to match the operating logic level of the test device as shown in [Figure 6](#)
- Remove the I2C Select jumper from the control header shown in [Figure 6](#)
- Connect SDA and SCL signals from user external source to J16
- Power PPC3-EVM-MB and configure device

5.3 External SPI

To set the PPC3-EVM-MB for external SPI bus, please follow the steps below:

- Remove power from PPC3-EVM-MB
- Set the VCC-I2C Select jumper to match the logic level of the user supplied signal as shown in [Figure 6](#)
- Set the IOVDD Select jumper to match the operating logic level of the test device as shown in [Figure 6](#)
- Remove the SPI Select jumper from the control header shown in [Figure 6](#)
- Connect SCLK, MOSI, MISO, SS0, and SS1 signals from user external source to J16

5.4 External Shutdown

When removed, SD-CTRL will apply a high logic to the SDZ output of PPC3-EVM-MB. If this jumper is inserted and the SD pin of J16 is left floating SDZ will be pulled low. In addition, while SD-CTRL is inserted an external input may be driven on the SD pin of J16.

5.5 Daisy Chain Connection

PPC3-EVM-MB allows for multiple boards to be ganged together to allow for increased channel counts, shown below in [Figure 8](#). The TI USB Driver will support up to 8 channels. Only one board needs to be connected via USB, and all other boards must be configured for external input as described above.

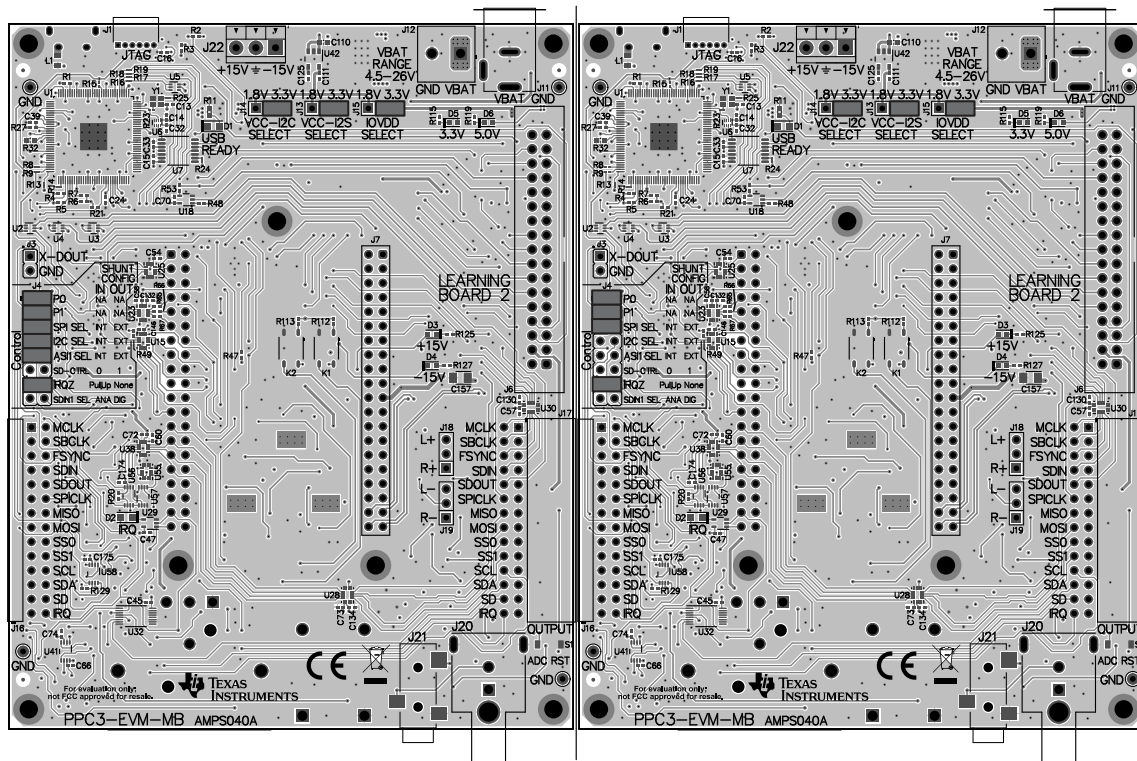

Figure 8. Daisy Chain Connection

6 Differential to Single Ended Filter

The Class-D modulation scheme typical to many Texas Instruments low power audio devices can benefit from a differential to single ended filter used for THD+N measurements. The modulation scheme varies from AD and BD modulation, and in most cases, this modulation scheme results with only one output being actively driven at a time. As a result, impedance mismatches in measurement equipment apparent to each output may produce artificially elevated THD+N results. A differential to single ended filter is available on this board to help improve customer THD+N measurements.

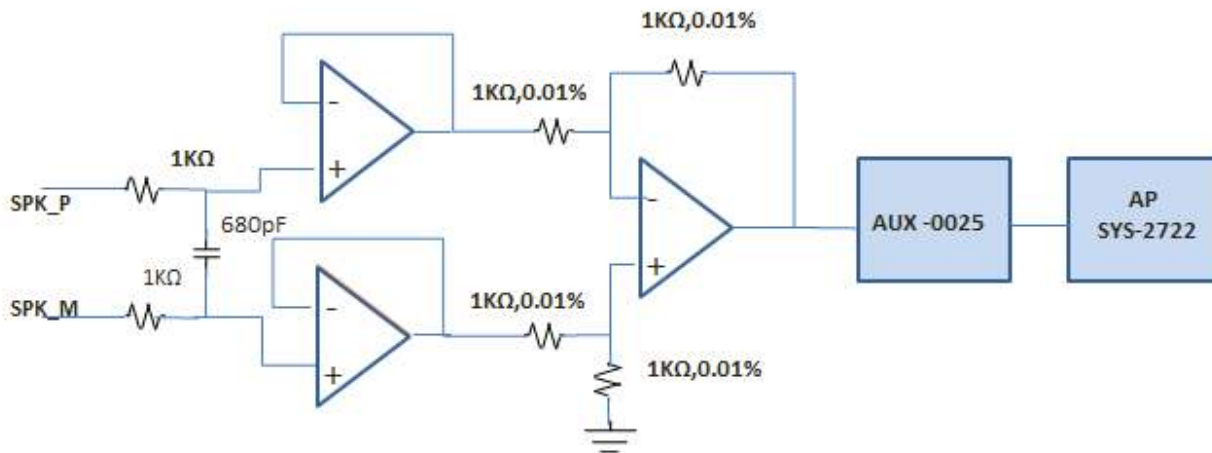

Figure 9. Differential to Single Ended Filter

To use the filter, apply a $\pm 15\text{-V}$ supply at J22 as shown in Figure 10.

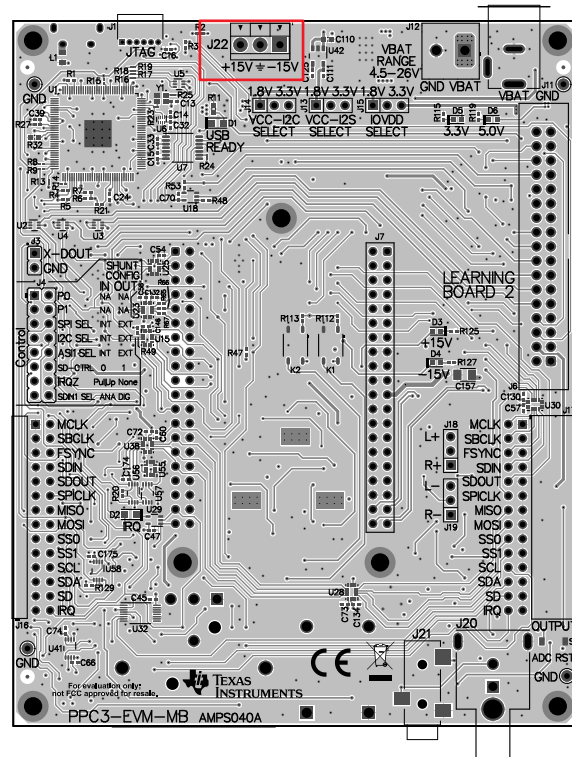

Figure 10. EVM Filter Setup

The output of the filter may be measured across the banana jack terminals, J10 and J8. J10 will provide GND while J8 will provide a single ended output that is 1/2 the input signal.

J18 and J19 select inputs from the connected daughter card to the filter. These jumpers should be set to select either L+/L- or R+/R-.

7 PPC3-EVM-MB Schematics

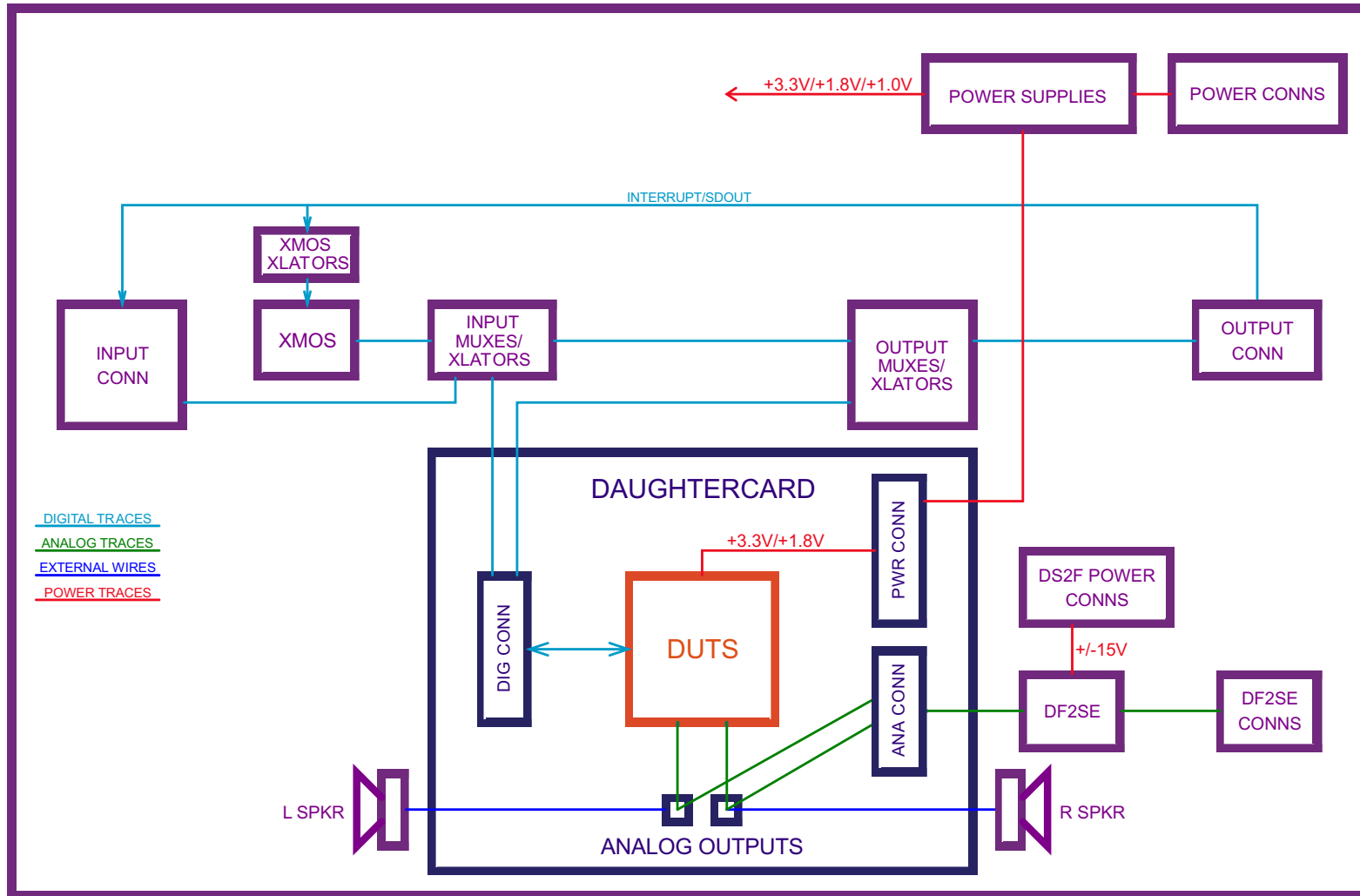

Figure 11. Schematic 1

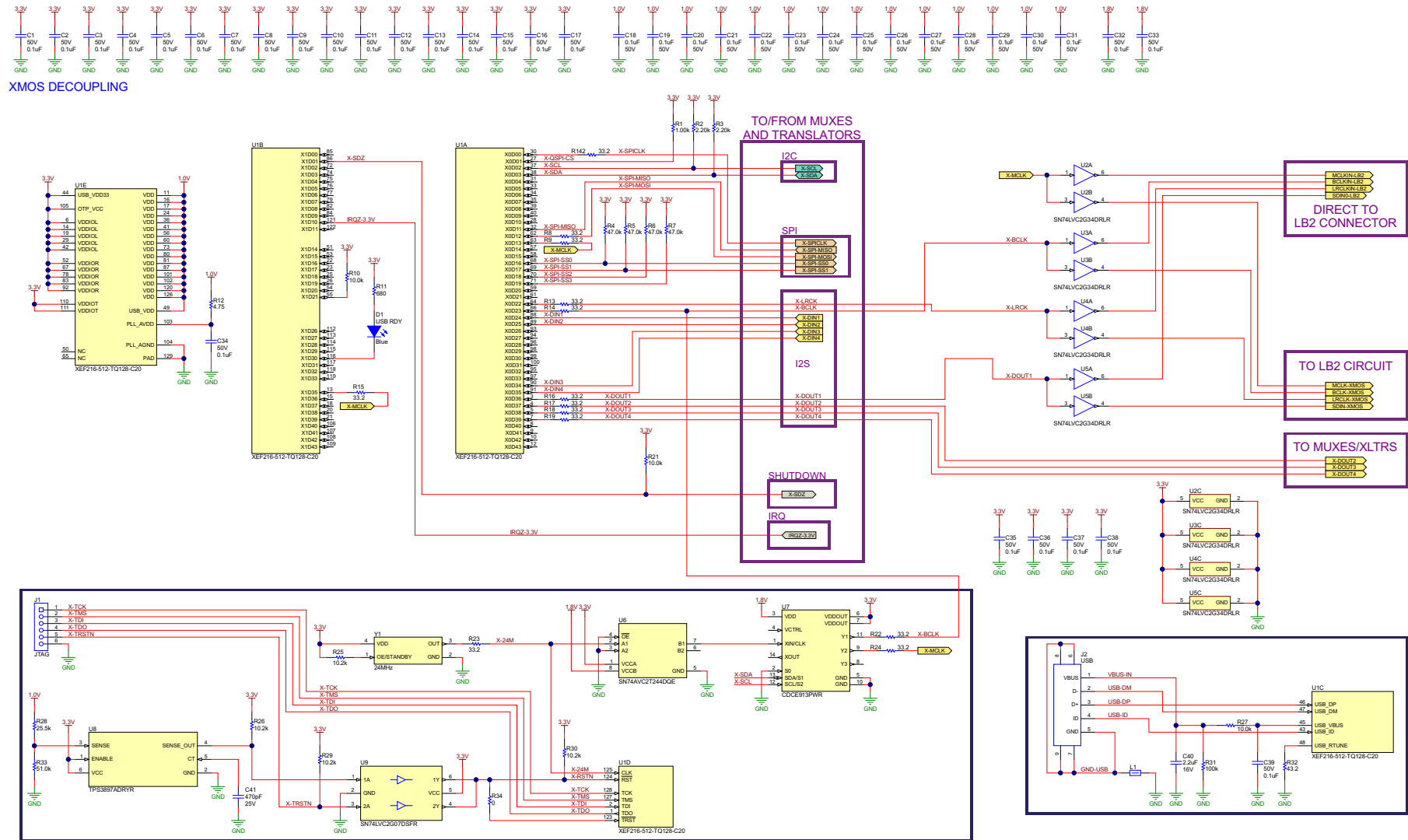

Figure 12. Schematic 2

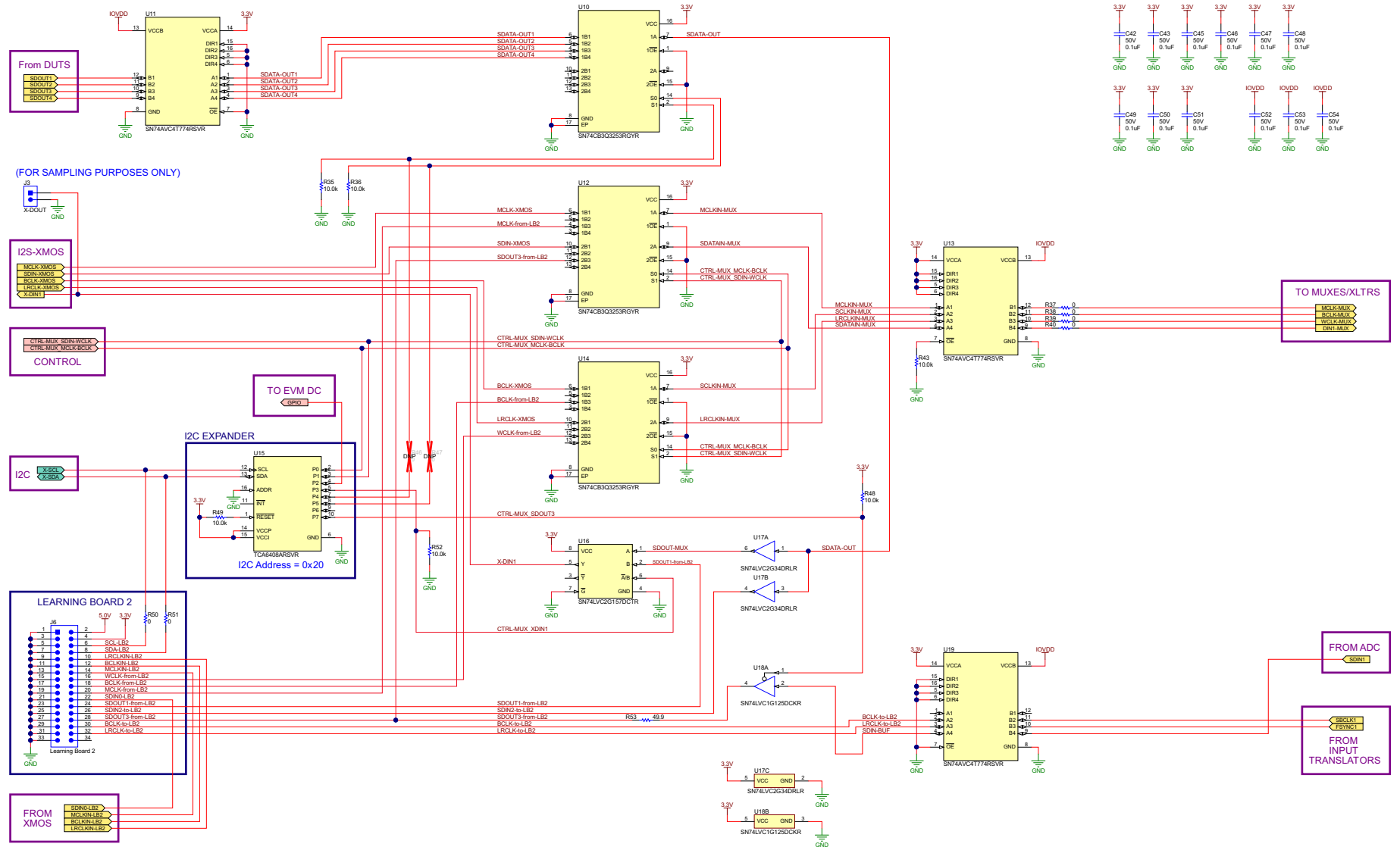

Figure 13. Schematic 3

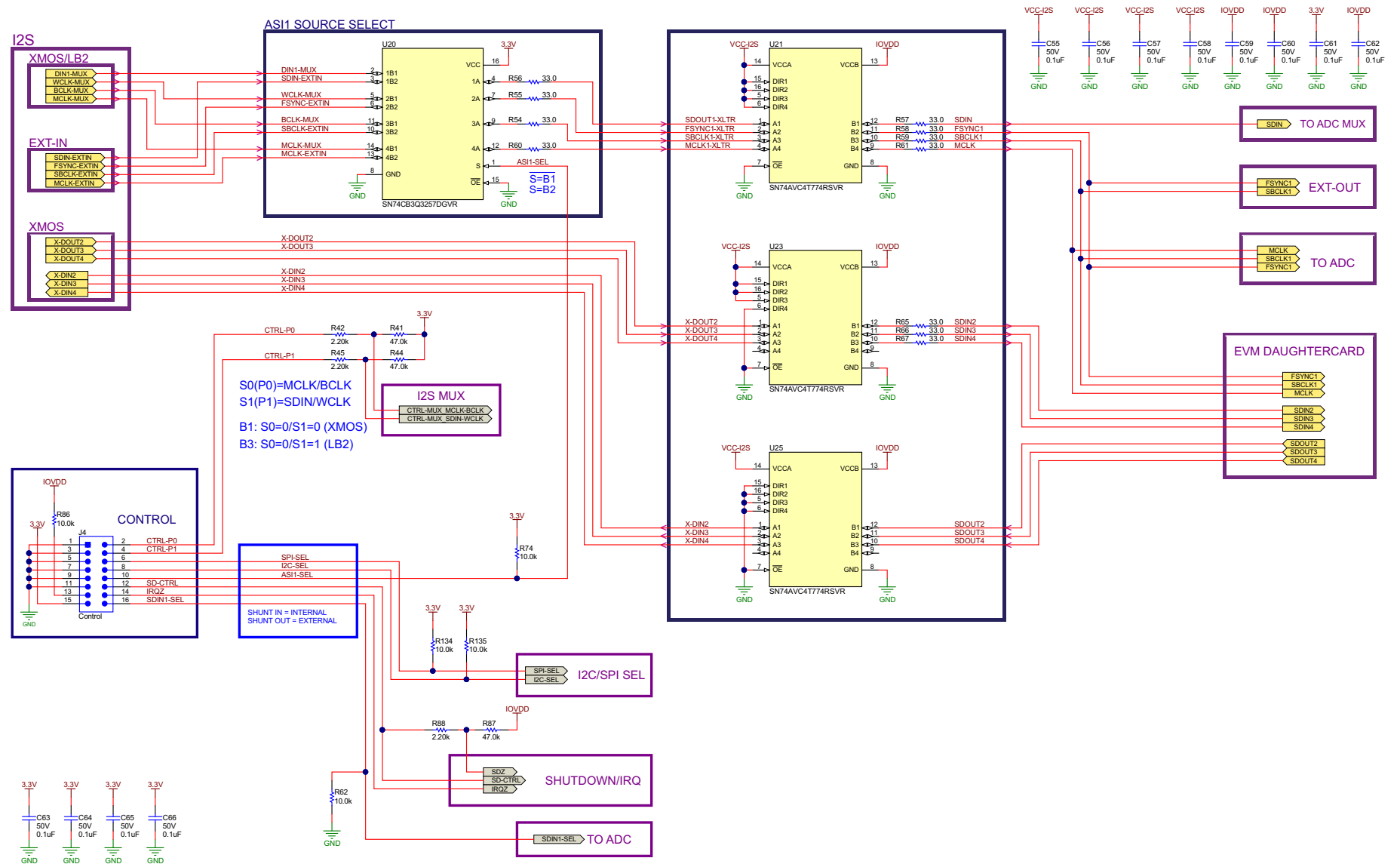

Figure 14. Schematic 4

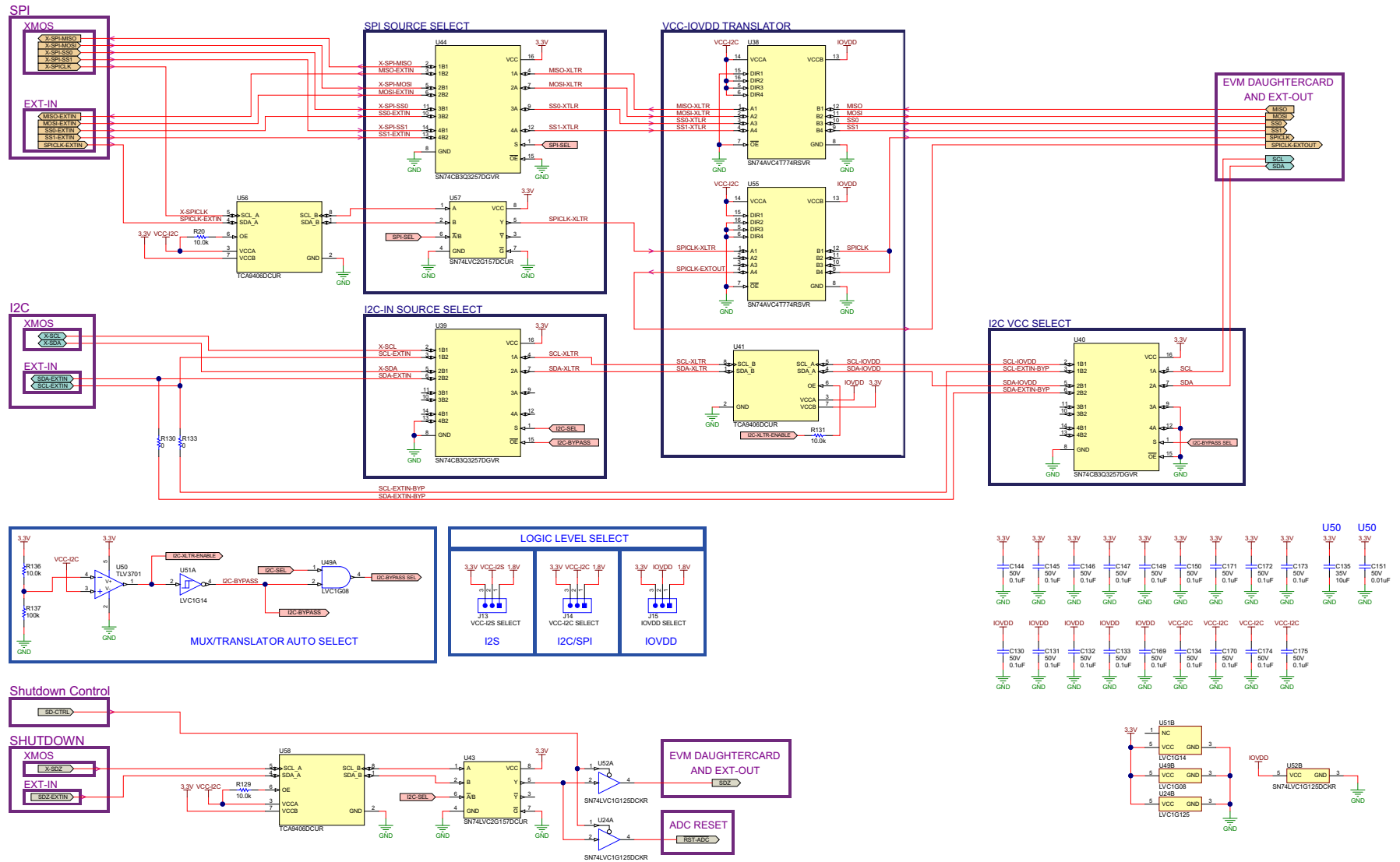

Figure 15. Schematic 5

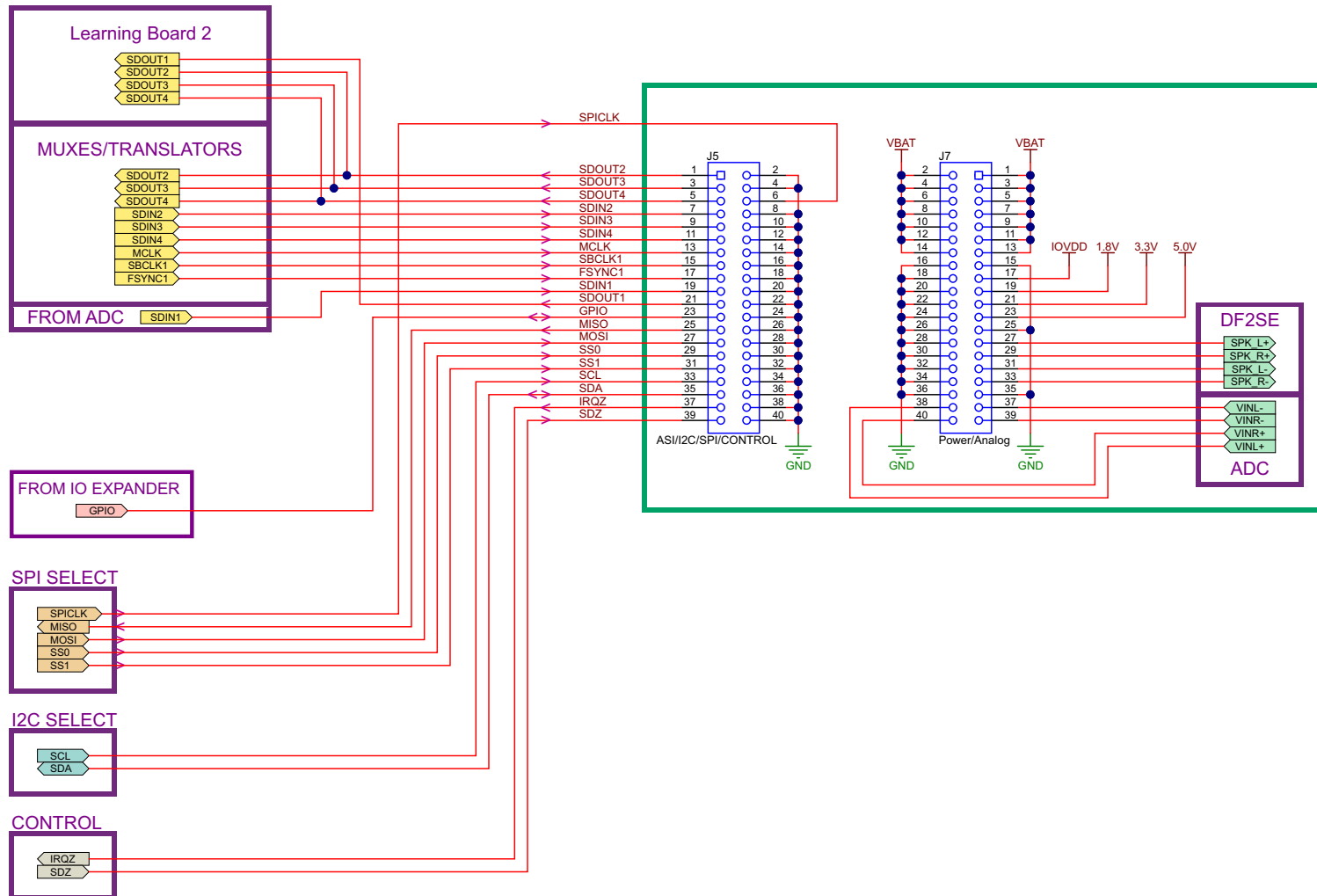

Figure 16. Schematic 6

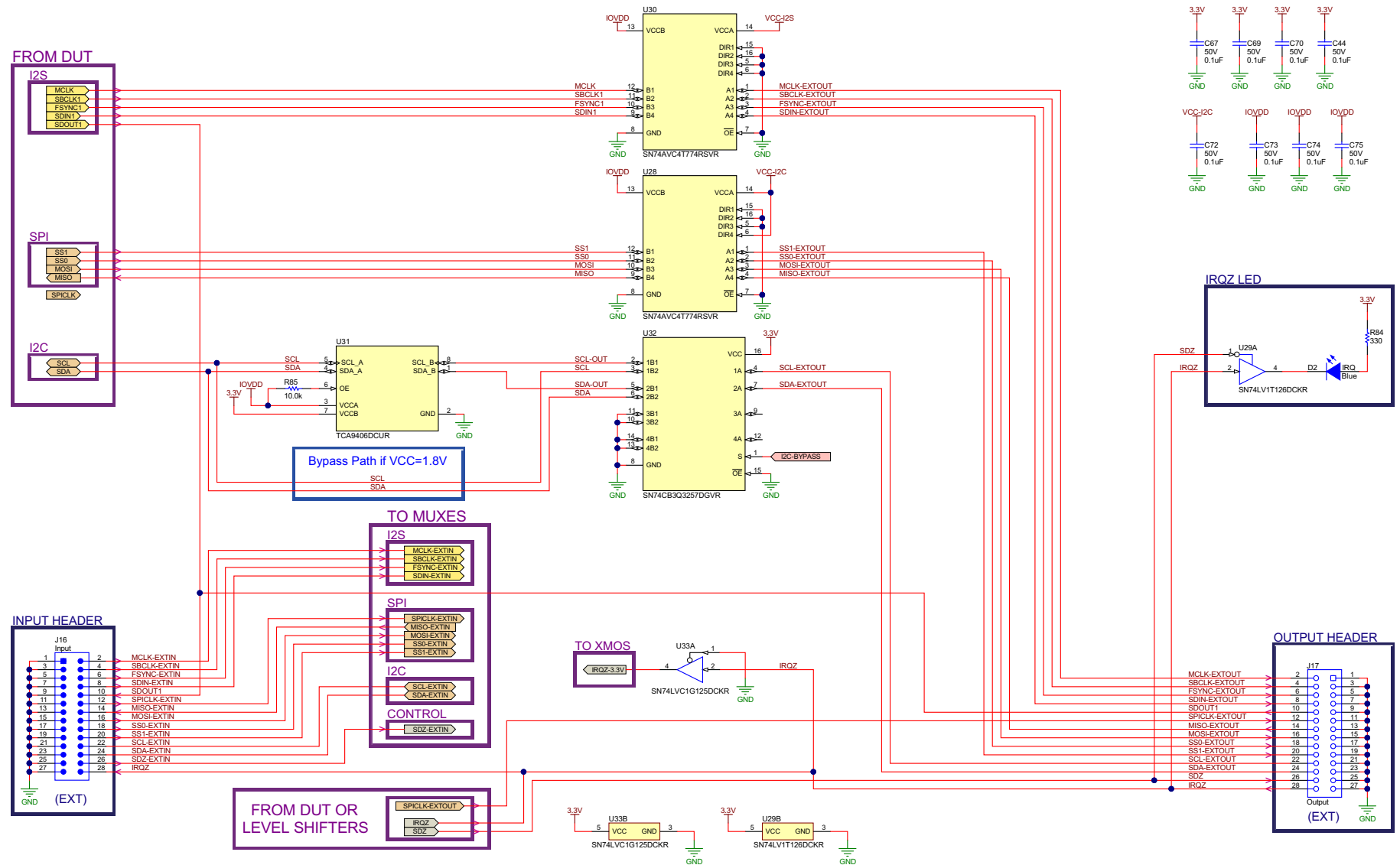

Figure 18. Schematic 8

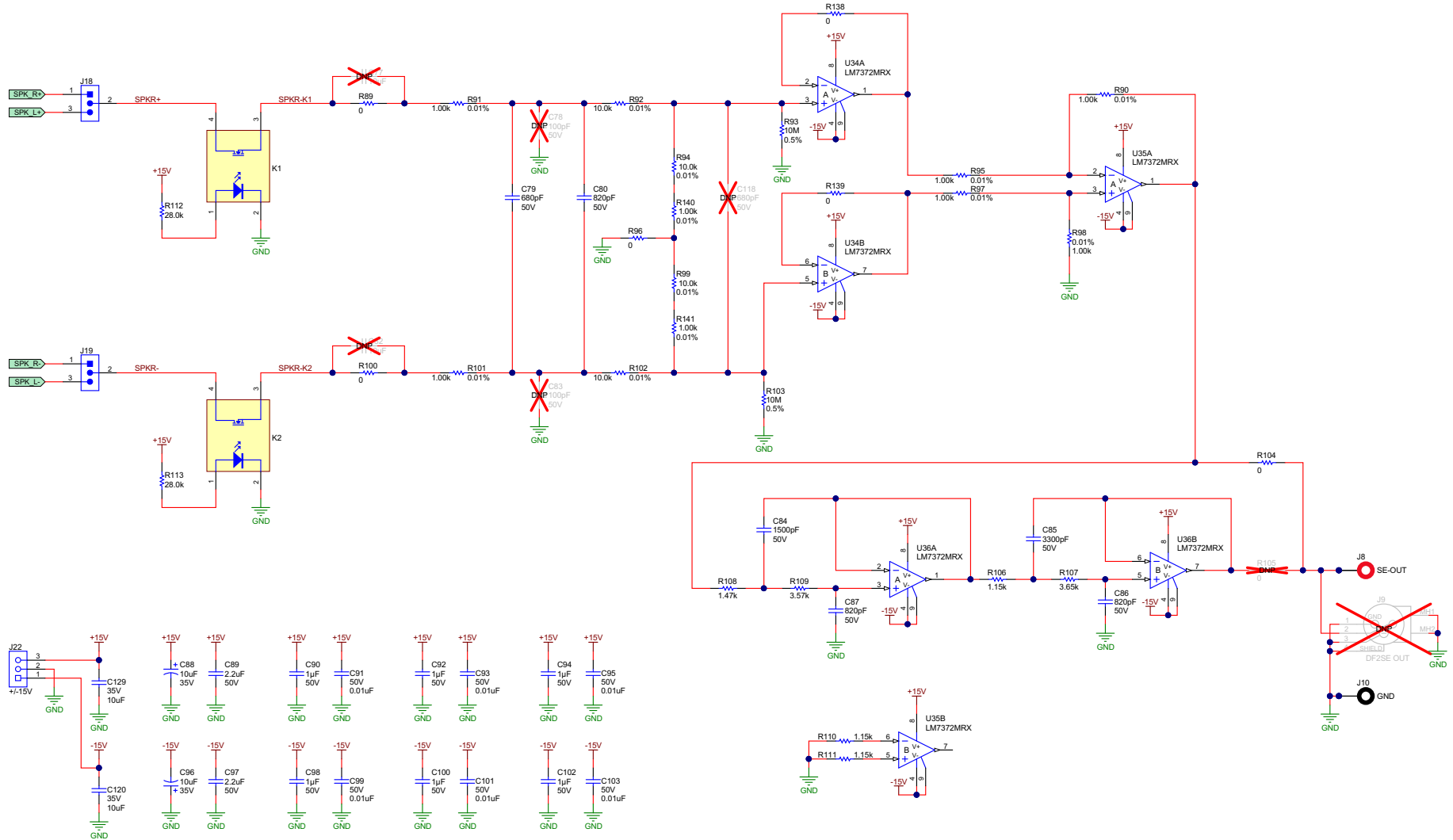
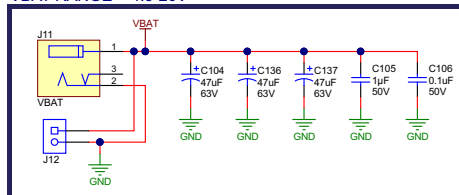
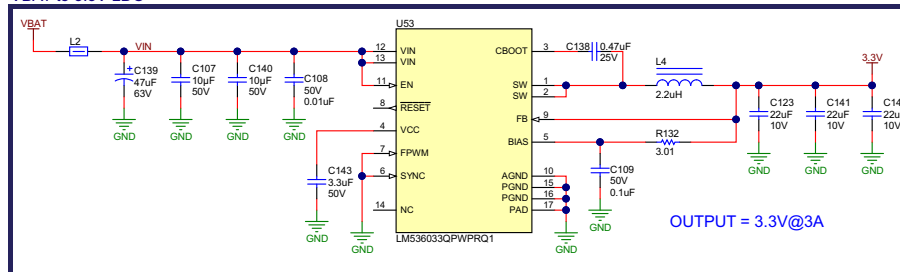

Figure 19. Schematic 9

VBAT RANGE = 4.5-26V



VBAT to 3.3V LDO



3.3V to 1.8V LDO

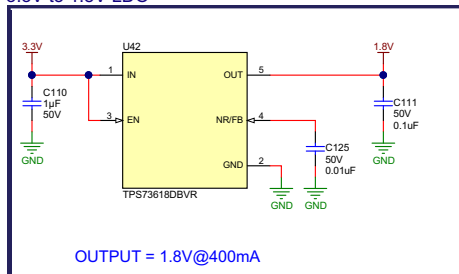

3.3V to 1V BUCK LDO for XMOS

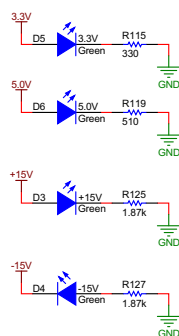
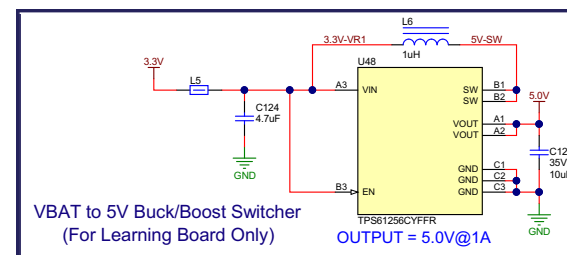
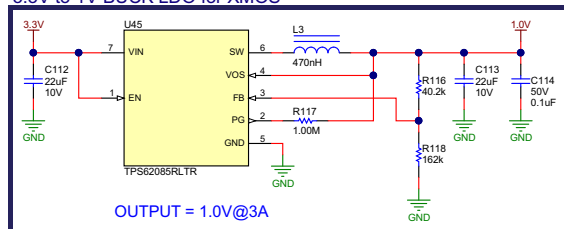

Figure 20. Schematic 10

8 PPC3-EVM-MB Layer Plots

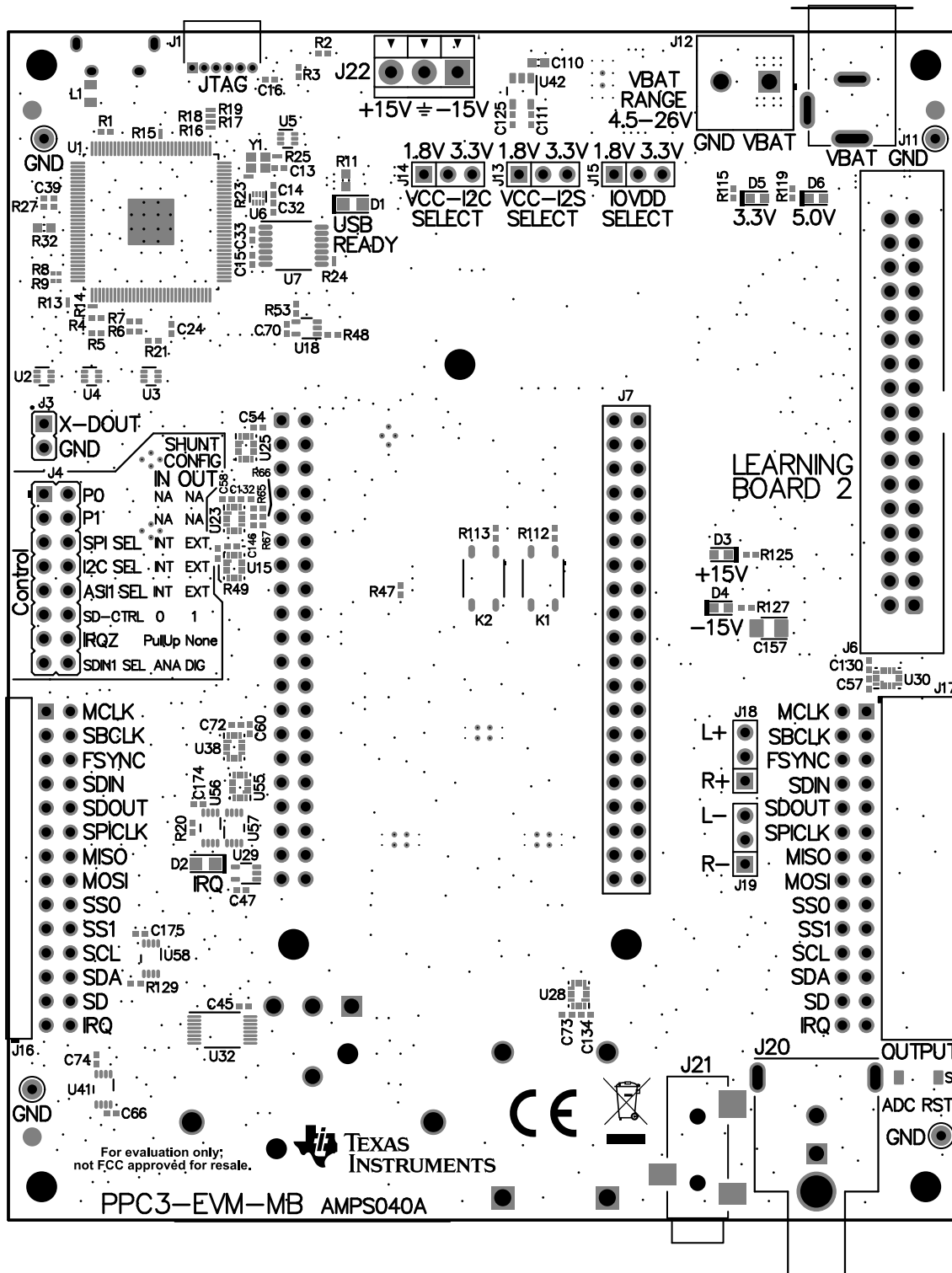

Figure 21. PPC3-EVM-MB Top Assembly

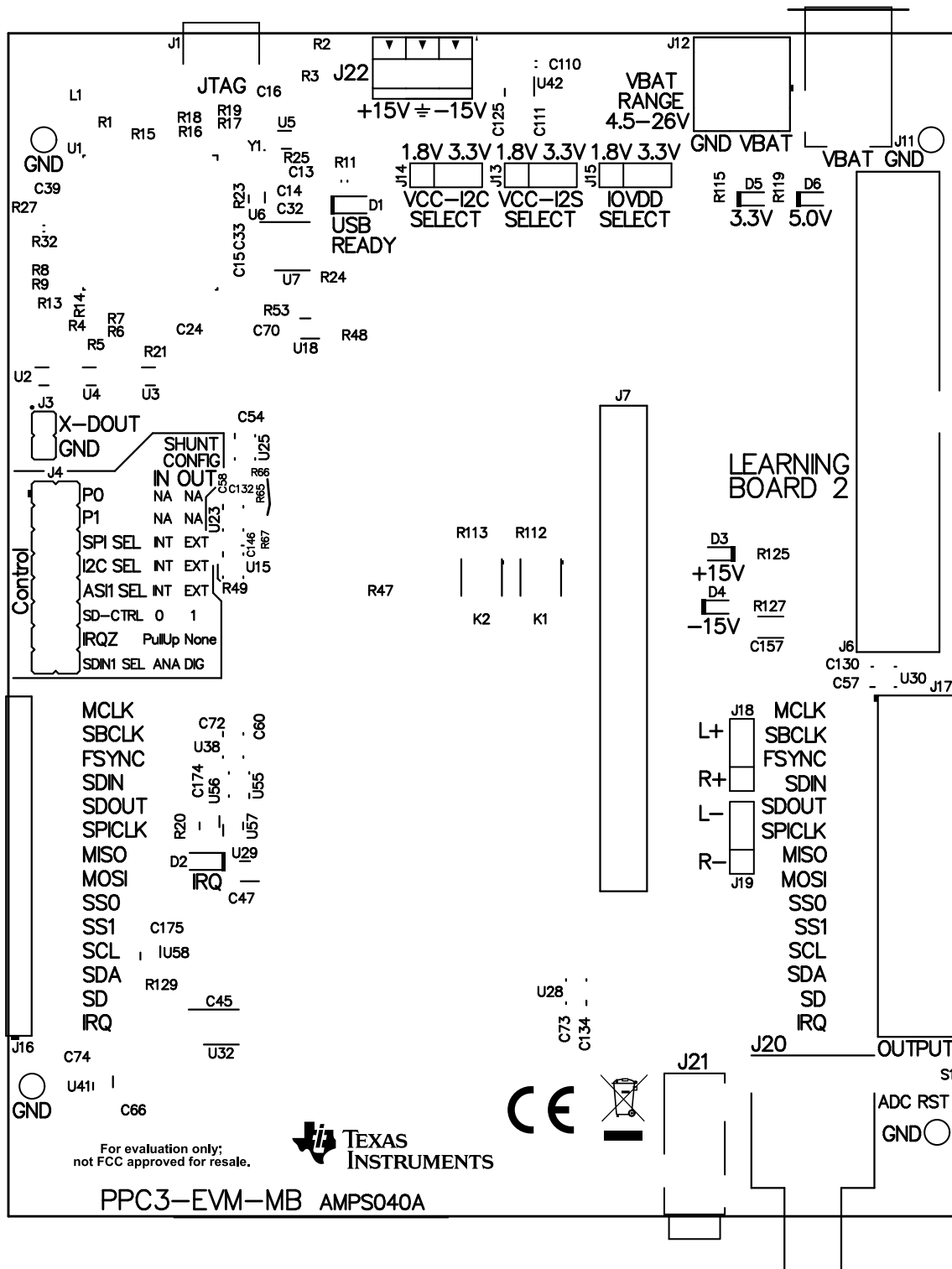

Figure 22. PPC3-EVM-MB Top Silk Screen

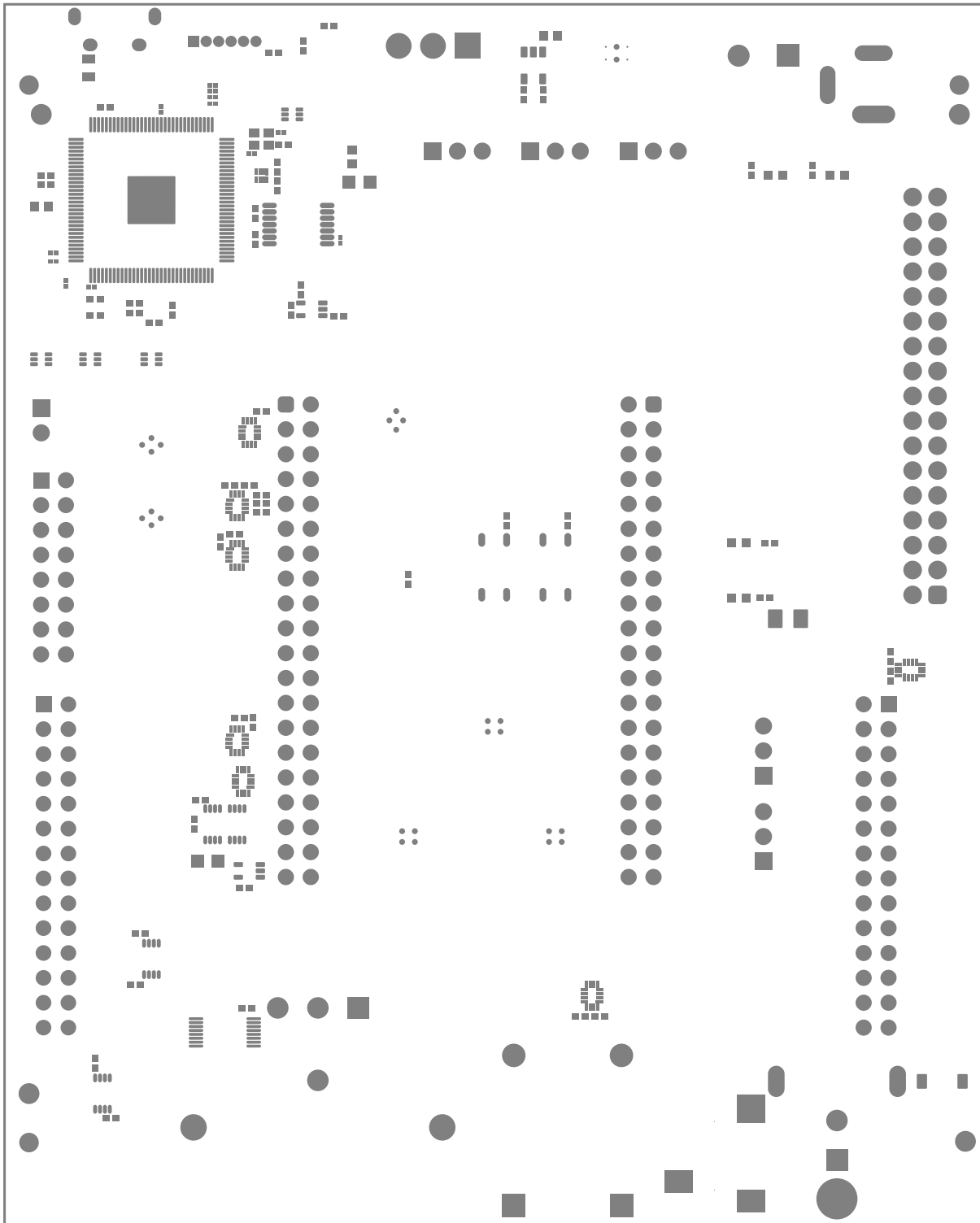

Figure 23. PPC3-EVM-MB Top Solder

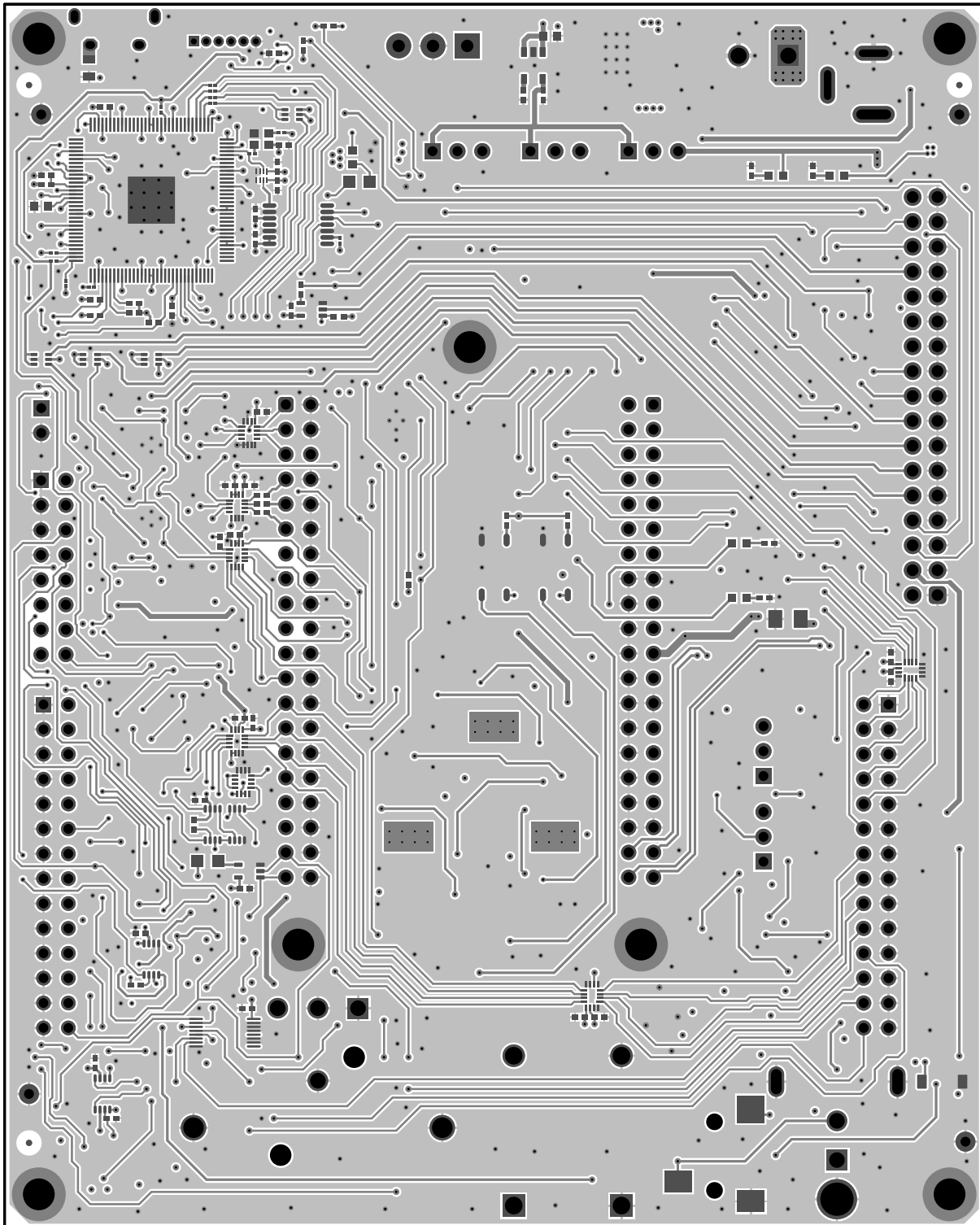

Figure 24. PPC3-EVM-MB Top Copper

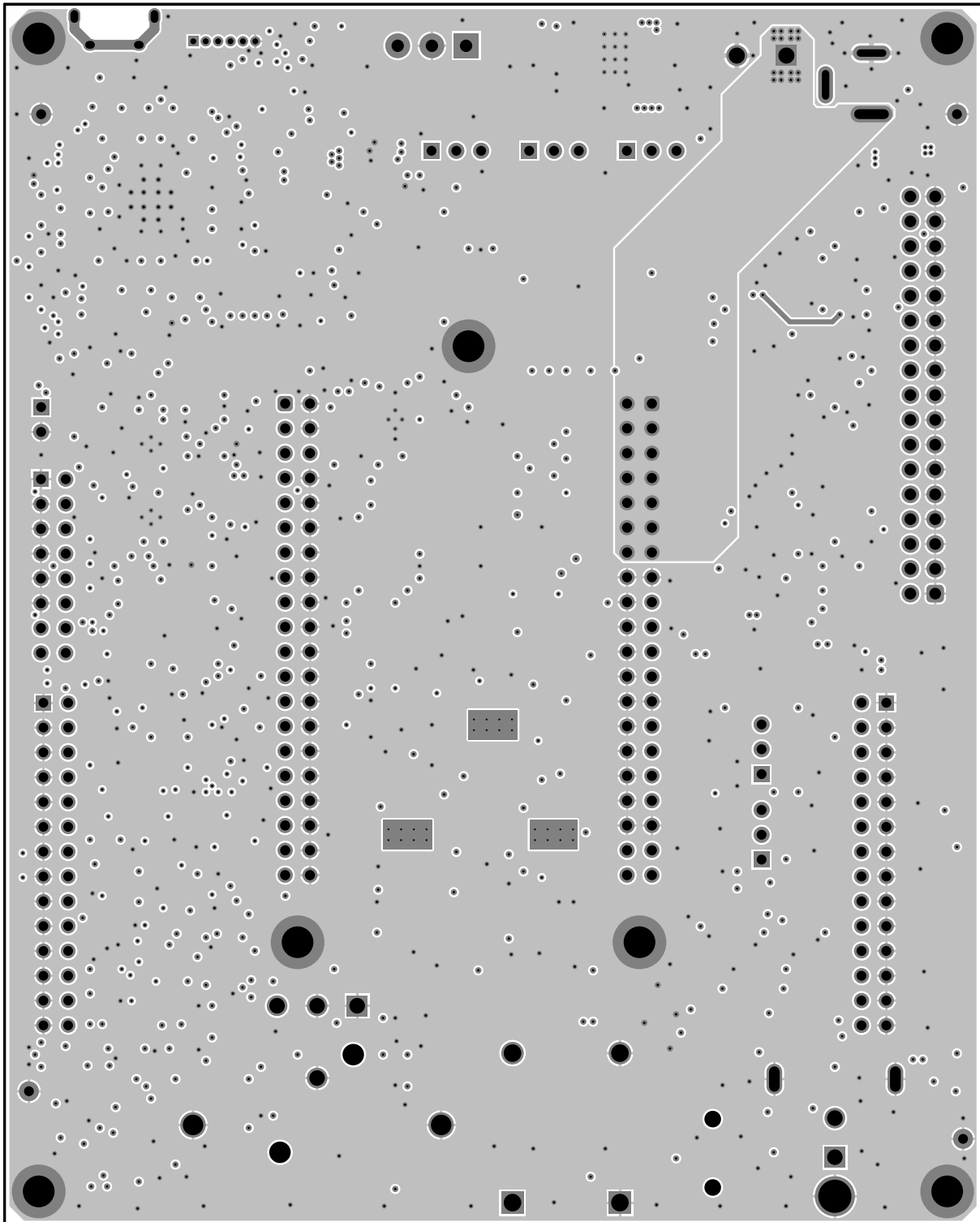

Figure 25. PPC3-EVM-MB Copper Layer 2

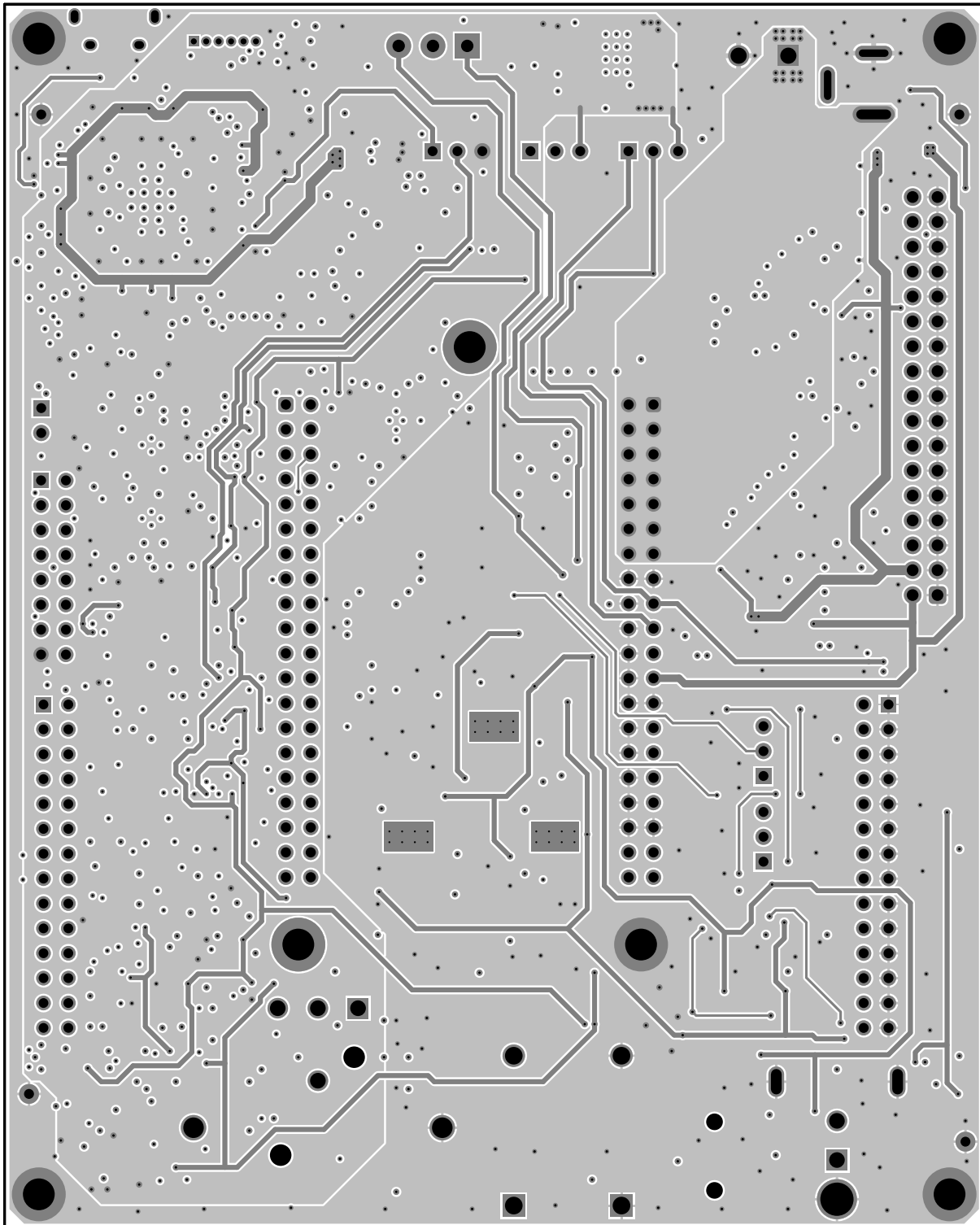

Figure 26. PPC3-EVM-MB Copper Layer 3

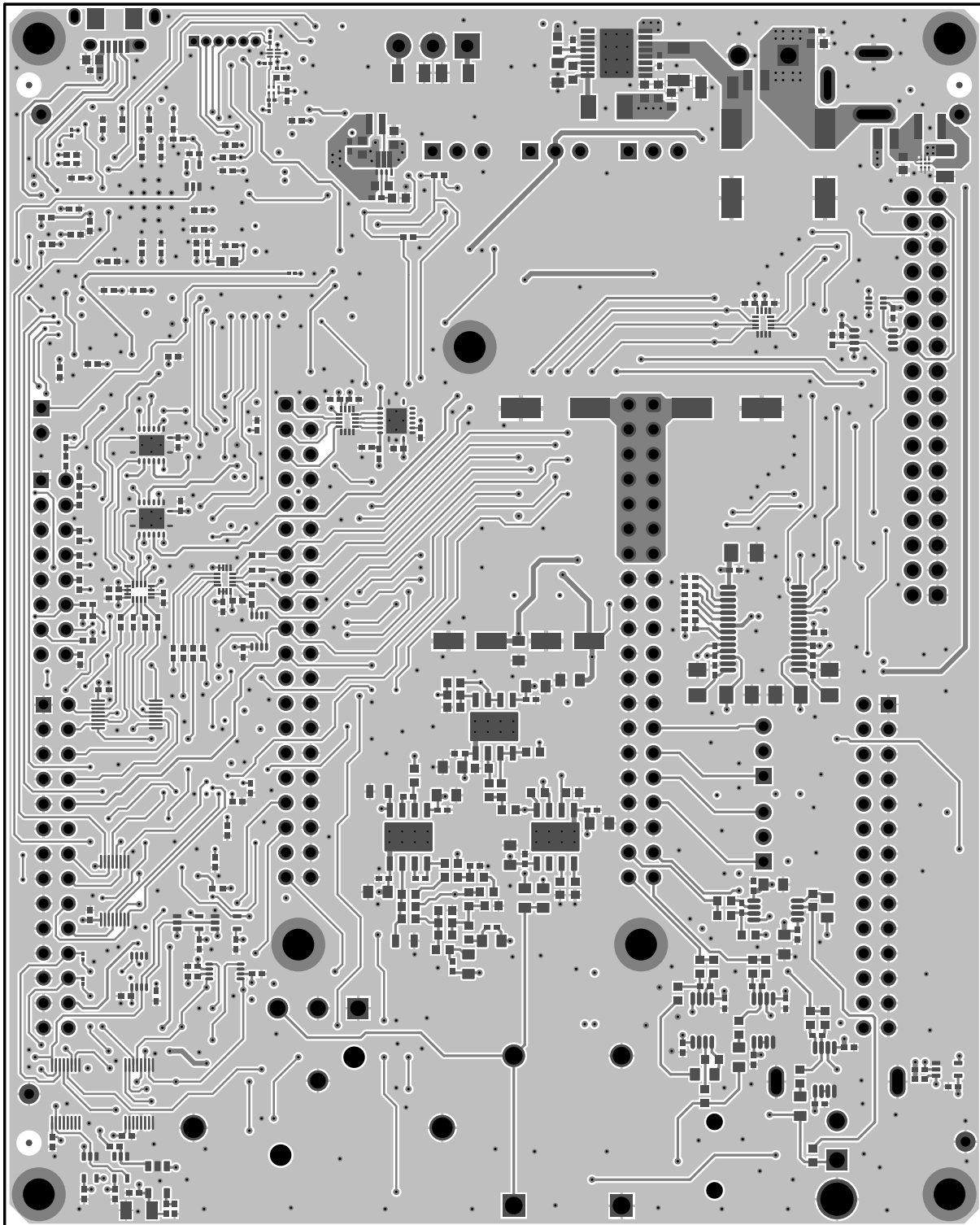

Figure 27. PPC3-EVM-MB Bottom Copper

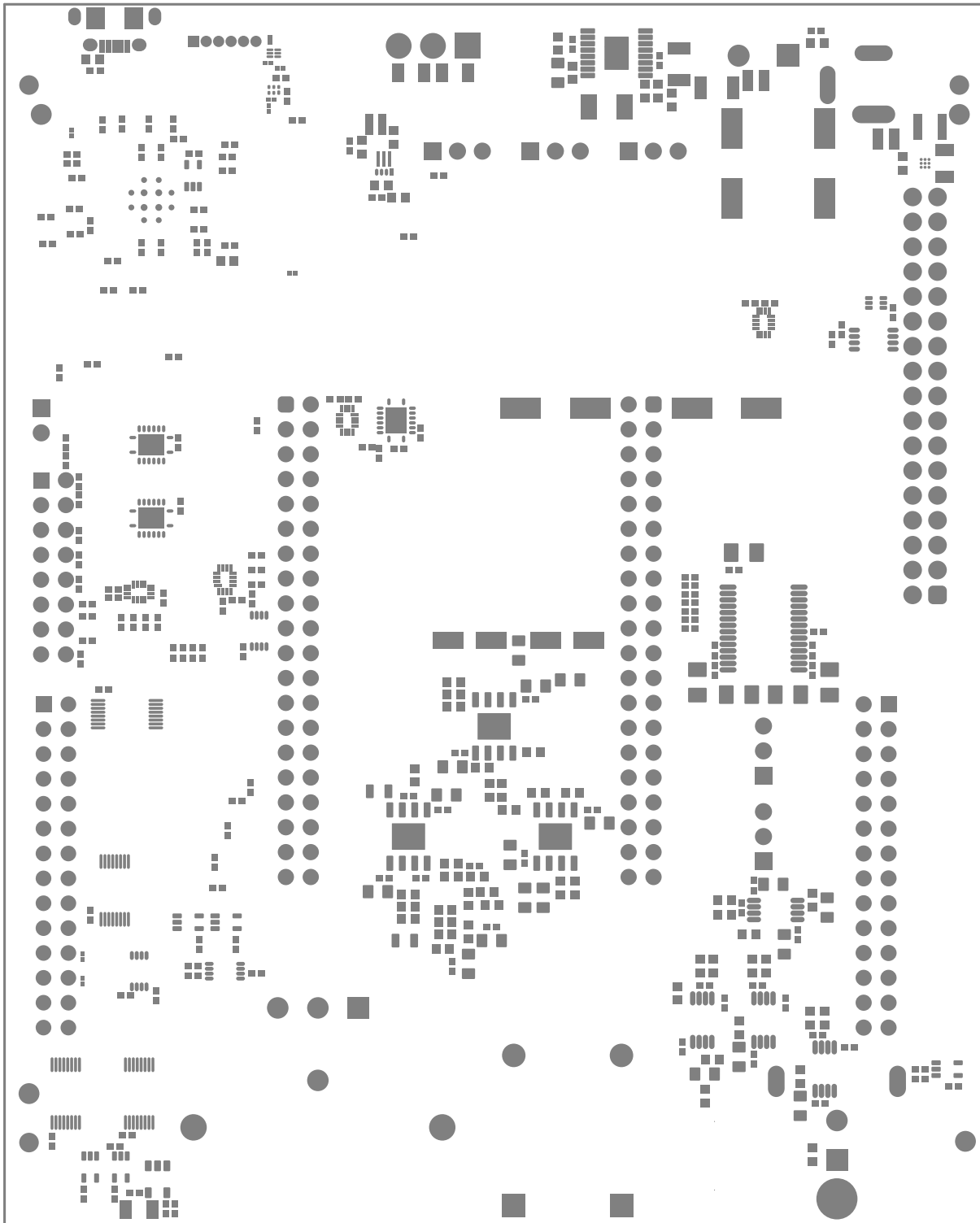

Figure 28. PPC3-EVM-MB Bottom Solder

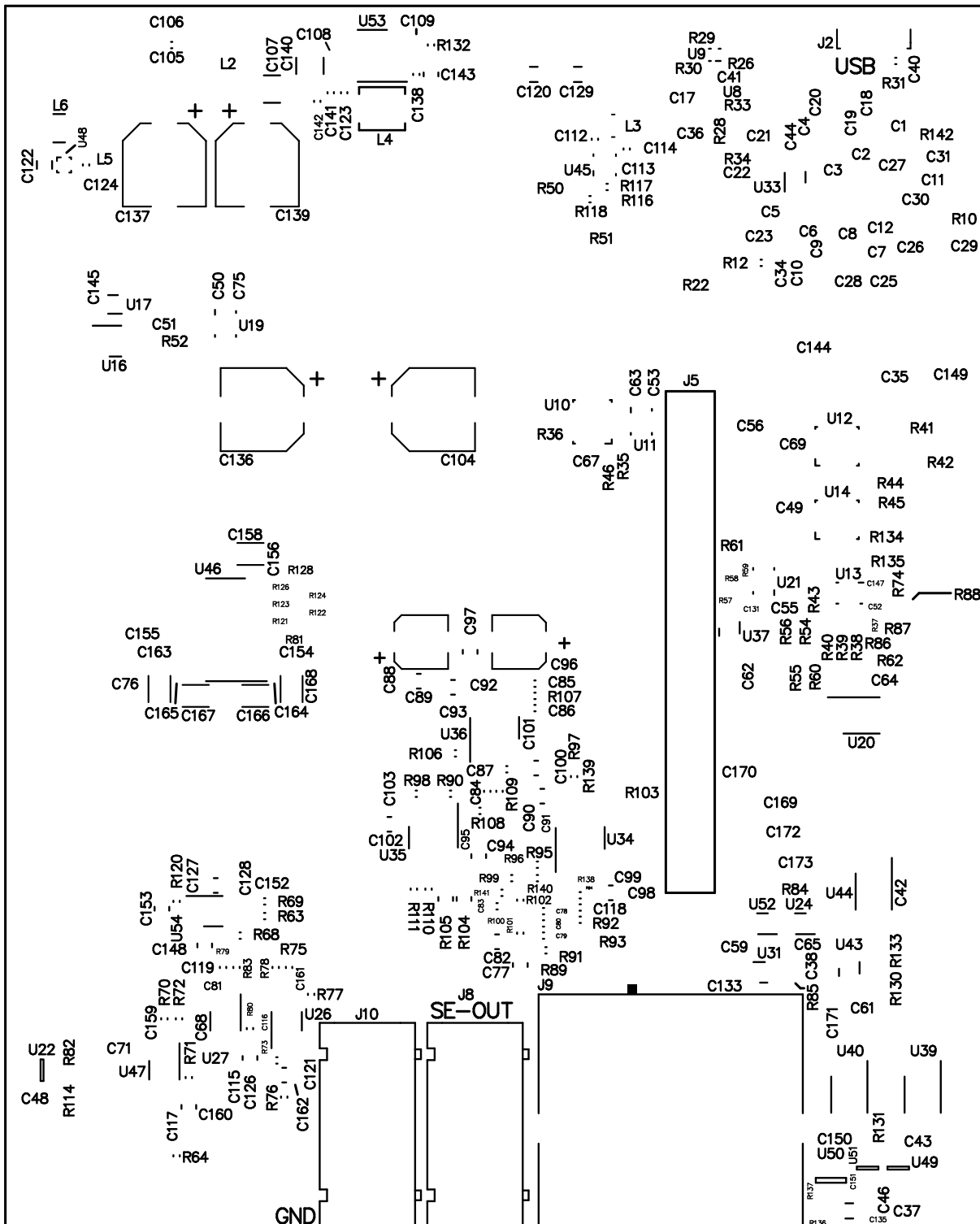

Figure 29. PPC3-EVM-MB Bottom Silk Screen

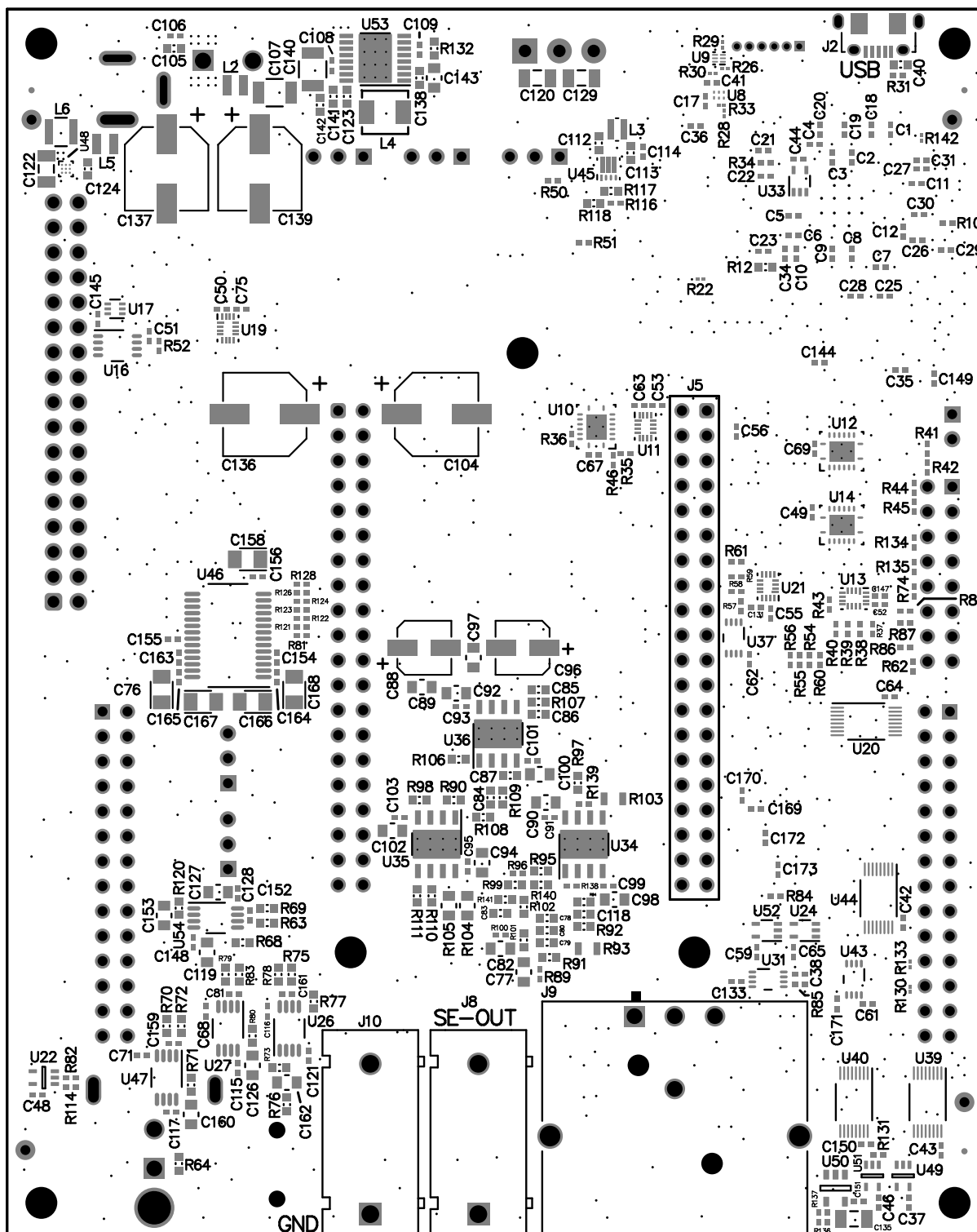

Figure 30. PPC3-EVM-MB Bottom Assembly

9 PPC3-EVM-MB BOM

Table 4. PPC3-EVM-MB BOM

Designator	Value	Description	Package Reference	PartNumber	Manufacturer	Alternate Part Number	Alternate Manufacturer
PCB1		Printed Circuit Board		AMPS040	Any		
C1, C2, C3, C4, C5, C6, C7, C8, C9, C10, C11, C12, C13, C14, C15, C16, C17, C18, C19, C20, C21, C22, C23, C24, C25, C26, C27, C28, C29, C30, C31, C32, C33, C34, C35, C36, C37, C38, C39, C42, C43, C44, C45, C46, C47, C48, C49, C50, C51, C52, C53, C54, C55, C56, C57, C58, C59, C60, C61, C62, C63, C64, C65, C66, C67, C69, C70, C72, C73, C74, C75, C106, C109, C111, C114, C130, C131, C132, C133, C134, C144, C145, C146, C147, C149, C150, C155, C156, C164, C165, C169, C170, C171, C172, C173, C174, C175	0.1µF	CAP, CERM, 0.1 µF, 50 V, ± 10%, X7R, 0402	0402	C1005X7R1H104K050BB	TDK		
C40	2.2µF	CAP, CERM, 2.2 µF, 16 V, ± 10%, X7R, 0603	0603	EMK107BB7225MA-T	Taiyo Yuden		
C41	470pF	CAP, CERM, 470 pF, 25 V, ± 5%, C0G/NP0, 0402	0402	GRM1555C1E471JA01D	MuRata		
C68, C71, C91, C93, C95, C99, C101, C103, C108, C115, C116, C117, C121, C125, C128, C148, C151, C154, C163	0.01µF	CAP, CERM, 0.01 µF, 50 V, ± 10%, X7R, AEC-Q200 Grade 1, 0402	0402	CGA2B3X7R1H103K050BB	TDK		
C76, C157, C158, C168	10µF	CAP, TA, 10 µF, 10 V, ± 10%, SMD	3216-18	T493A106K010AH6120	Kemet		
C79	680pF	CAP, CERM, 680 pF, 50 V, ± 1%, C0G/NP0, 0603	0603	06035A681FAT2A	AVX		
C80, C86, C87	820pF	CAP, CERM, 820 pF, 50 V, ± 5%, C0G/NP0, 0603	0603	06035A821JAT2A	AVX		
C81, C152, C159, C161	1800pF	CAP, CERM, 1800 pF, 100 V, ± 10%, X7R, 0402	0402	GRM155R72A182KA01D	MuRata		
C84	1500pF	CAP, CERM, 1500 pF, 50 V, ± 5%, C0G/NP0, 0603	0603	GRM1885C1H152JA01D	MuRata		
C85	3300pF	CAP, CERM, 3300 pF, 50 V, ± 5%, C0G/NP0, 0603	0603	GRM1885C1H332JA01D	MuRata		
C88, C96	10µF	CAP, AL, 10 µF, 35 V, ± 20%, 0.76 Ω, SMD	5x5.8	UUD1V100MCL1GS	Nichicon		
C89, C97	2.2µF	CAP, CERM, 2.2 µF, 50 V, ± 10%, X5R, 0805	0805	C2012X5R1H225K125AB	TDK		
C90, C92, C94, C98, C100, C102	1µF	CAP, CERM, 1 µF, 50 V, ± 10%, X7R, AEC-Q200 Grade 1, 0805	0805	08055C105K4Z2A	AVX		
C104, C136, C137, C139	47µF	CAP, AL, 47 µF, 63 V, ± 20%, 0.65 Ω, AEC-Q200 Grade 2, SMD	SMT Radial F	EEE-FK1J470P	Panasonic		
C105, C110	1µF	CAP, CERM, 1 µF, 50 V, ± 20%, X5R, AEC-Q200 Grade 3, 0603	0603	CGA3E3X5R1H105M080AB	TDK		
C107, C140	10µF	CAP, CERM, 10 µF, 50 V, ± 20%, JB, 1210	1210	C3225JB1H106M250AB	TDK		
C112, C113, C123, C141, C142	22µF	CAP, CERM, 22 µF, 10 V, ± 20%, X5R, 0603	0603	C1608X5R1A226M080AC	TDK		
C119, C126, C127, C153, C160, C162	10µF	CAP, CERM, 10 µF, 25 V, ± 10%, X5R, 0805	0805	CC0805KKX5R8BB106	Yageo		
C120, C122, C129, C135	10µF	CAP, CERM, 10 µF, 35 V, ± 10%, X7R, 1206_190	1206_190	GMK316AB7106KL-TR	Taiyo Yuden		
C124	4.7µF	CAP, CERM, 4.7 µF, 16 V, ± 10%, X5R, 0603	0603	GRM188R61C475KAAJ	MuRata		
C138	0.47µF	CAP, CERM, 0.47 µF, 25 V, ± 10%, X7R, 0603	0603	GRM188R71E474KA12D	MuRata		

Table 4. PPC3-EVM-MB BOM (continued)

Designator	Value	Description	Package Reference	PartNumber	Manufacturer	Alternate Part Number	Alternate Manufacturer
C143	3.3 μ F	CAP, CERM, 3.3 μ F, 50 V, \pm 10%, X5R, 0805	0805	C2012X5R1H335K125AB	TDK		
C166, C167	0.1 μ F	CAP, TA, 0.1 μ F, 35 V, \pm 10%, 20 Ω , SMD	3216-18	293D104X9035A2TE3	Vishay-Sprague		
D1, D2	Blue	LED, Blue, SMD	LED_0805	LTST-C170TBKT	Lite-On		
D3, D4, D5, D6	Green	LED, Green, SMD	LED_0603	LTST-C191KGKT	Lite-On		
H1, H2, H3, H4, H5, H6, H7		MACHINE SCREW PAN PHILLIPS M3	M3 Screw	RM3X8MM 2701	APM HEXSEAL		
H8, H9, H10, H11, H12, H13, H14		Standoff, Threaded, 20mm, M3, Aluminum	5mm Hex Female Standoff	24437	Keystone		
J1		Receptacle, 50mil, 6x1, Gold, R/A, TH	6x1 Receptacle	LPPB061NGCN-RC	Sullins Connector Solutions		
J2		Connector, Receptacle, Micro-USB Type AB, R/A, Bottom Mount SMT	Connector, USB Micro AB	DX4R205JJAR1800	JAE Electronics		
J3		Header, 100mil, 2x1, Gold, TH	Sullins 100mil, 1x2, 230 mil above insulator	PBC02SAAN	Sullins Connector Solutions		
J4		Header, 2.54 mm, 8x2, Tin, Vertical, TH	Header, 2.54 mm, 8x2, TH	PEC08DAAN	Sullins Connector Solutions		
J5, J7		Receptacle, 2.54mm, 20x2, Gold, TH	Receptacle, 2.54mm, 20x2, TH	SSW-120-03-G-D	Samtec		
J6		Header(shrouded), 2.54mm, 17x2, Gold, TH	Header(shrouded), 2.54mm, 17x2, TH	302-S341	On-Shore Technology		
J8		Standard Banana Jack, insulated, 10A, red	571-0500	571-0500	DEM Manufacturing		
J10		Standard Banana Jack, insulated, 10A, black	571-0100	571-0100	DEM Manufacturing		
J11		Power Jack, mini, 2.5mm OD, R/A, TH	Jack, 14.5x11x9mm	RAPC712X	Switchcraft		
J12		Terminal Block, 5.08mm, 2x1, TH	Terminal Block, 5.08mm, 2x1, TH	0395443002	Molex		
J13, J14, J15, J18, J19		Header, 100mil, 3x1, Gold, TH	PBC03SAAN	PBC03SAAN	Sullins Connector Solutions		
J16		Header, 2.54mm, 14x2, Gold, R/A, TH	Header, 2.54mm, 14x2, R/A, TH	PRPC014DBAN-M71RC	Sullins Connector Solutions		
J17		Receptacle, 2.54mm, 14x2, Gold, R/A, TH	Receptacle, 2.54mm, 14x2, R/A, TH	PPPC142LJBN-RC	Sullins Connector Solutions		
J21		Audio Jack, 3.5mm, Stereo, R/A, SMT	Audio Jack SMD	SJ-3523-SMT	CUI Inc.		
J22		Terminal Block, 3.5mm Pitch, 3x1, TH	10.5x8.2x6.5mm	ED555/3DS	On-Shore Technology		
K1, K2		Relay, SPST-NO (1 Form A), 0.7 A, SMD	4.089x3.81mm	CPC1002NTR	IXYS		
L1	30 Ω	Ferrite Bead, 30 Ω @ 100 MHz, 6 A, 0805	0805	MPZ2012S300AT000	TDK		
L2, L5	300 Ω	Ferrite Bead, 300 Ω @ 100 MHz, 3.1 A, 0806	0806	NFZ2MSM301SN10L	MuRata		
L3	470nH	Inductor, Shielded, Ferrite, 470 nH, 2 A, 0.059 Ω , SMD	Inductor, 2x1.2x2mm	VLS2012ET-R47N	TDK		
L4	2.2 μ H	Inductor, Shielded, 2.2 μ H, 4 A, 0.061 Ω , AEC-Q200 Grade 0, SMD	4.45x1.8x4.06mm	SRP4020TA-2R2M	Bourns		
L6	1 μ H	Inductor, Flat Wire, 1 μ H, 3.1 A, 0.045 Ω , SMD	3.2x1.2x2.5mm	1277AS-H-1R0M=P2	MuRata Toko		
R1	1.00k	RES, 1.00 k, 1%, 0.1 W, 0402	0402	ERJ-2RKF1001X	Panasonic		
R2, R3, R42, R45, R88	2.20k	RES, 2.20 k, 1%, 0.1 W, 0402	0402	ERJ-2RKF2201X	Panasonic		
R4, R5, R6, R7, R41, R44, R87, R114	47.0k	RES, 47.0 k, 1%, 0.0625 W, 0402	0402	RC0402FR-0747KL	Yageo America		

Table 4. PPC3-EVM-MB BOM (continued)

Designator	Value	Description	Package Reference	PartNumber	Manufacturer	Alternate Part Number	Alternate Manufacturer
R8, R9, R13, R14, R15, R16, R17, R18, R19, R22, R23, R24, R142	33.2	RES, 33.2, 1%, 0.05 W, 0201	0201	RC0201FR-0733R2L	Yageo America		
R10, R20, R21, R27, R35, R36, R43, R48, R49, R52, R82, R85, R86, R121, R122, R123, R124, R126, R128, R129, R134	10.0k	RES, 10.0 k, 1%, 0.063 W, 0402	0402	RC0402FR-0710KL	Yageo America		
R11	680	RES, 680, 1%, 0.1 W, 0603	0603	RC0603FR-07680RL	Yageo America		
R12	4.75	RES, 4.75, 1%, 0.1 W, 0603	0603	RC0603FR-074R75L	Yageo America		
R25, R26, R29, R30	10.2k	RES, 10.2 k, 1%, 0.05 W, 0201	0201	RC0201FR-0710K2L	Yageo America		
R28	25.5k	RES, 25.5 k, 1%, 0.05 W, 0201	0201	RC0201FR-0725K5L	Yageo America		
R31, R137	100k	RES, 100 k, 1%, 0.1 W, 0402	0402	ERJ-2RKF1003X	Panasonic		
R32	43.2	RES, 43.2, 1%, 0.1 W, 0603	0603	RC0603FR-0743R2L	Yageo America		
R33	51.0k	RES, 51.0 k, 1%, 0.05 W, 0201	0201	RC0201FR-0751KL	Yageo America		
R34, R37, R38, R39, R40, R50, R51, R96	0	RES, 0, 5%, 0.063 W, 0402	0402	ERJ-2GE0R00X	Panasonic		
R53	49.9	RES, 49.9, 1%, 0.063 W, AEC-Q200 Grade 0, 0402	0402	RMCF0402FT49R9	Stackpole Electronics Inc		
R54, R55, R56, R57, R58, R59, R60, R61, R65, R66, R67	33.0	RES, 33.0, 1%, 0.1 W, 0402	0402	ERJ-2RKF33R0X	Panasonic		
R62, R74, R131, R135, R136	10.0k	RES, 10.0 k, 1%, 0.1 W, 0402	0402	ERJ-2RKF1002X	Panasonic		
R63, R70, R75, R79	1.00k	RES, 1.00 k, 1%, 0.1 W, 0603	0603	RC0603FR-071KL	Yageo		
R64, R73, R76, R120	4.70k	RES, 4.70 k, 1%, 0.1 W, 0603	0603	RC0603FR-074K7L	Yageo		
R68, R71, R77, R80	3.30k	RES, 3.30 k, 1%, 0.1 W, 0603	0603	RC0603FR-073K3L	Yageo		
R69, R72, R78, R83	47.0	RES, 47.0, 1%, 0.1 W, 0603	0603	RC0603FR-0747RL	Yageo		
R84, R115	330	RES, 330, 1%, 0.1 W, AEC-Q200 Grade 0, 0402	0402	ERJ-2RKF3300X	Panasonic		
R89, R100, R138, R139	0	RES, 0, 5%, 0.1 W, AEC-Q200 Grade 0, 0402	0402	ERJ-2GE0R00X	Panasonic		
R90, R91, R95, R97, R98, R101, R140, R141	1.00k	RES, 1.00 k, 0.01%, 0.063 W, 0603	0603	RNCF0603TKY1K00	Stackpole Electronics Inc		
R92, R94, R99, R102	10.0k	RES, 10.0 k, 0.01%, 0.063 W, 0603	0603	RNCF0603TKY10K0	Stackpole Electronics Inc		
R93, R103	10Meg	RES, 10 M, 0.5%, 0.125 W, AEC-Q200 Grade 0, 2x1.25mm	2x1.25mm	CRCW080510M0DHEAP	Vishay-Dale		
R104	0	RES, 0, 5%, 0.125 W, 0805	0805	ERJ-6GEY0R00V	Panasonic		
R106, R110, R111	1.15k	RES, 1.15 k, 1%, 0.1 W, 0603	0603	RC0603FR-071K15L	Yageo America		
R107	3.65k	RES, 3.65 k, 1%, 0.1 W, 0603	0603	RC0603FR-073K65L	Yageo America		
R108	1.47k	RES, 1.47 k, 1%, 0.1 W, 0603	0603	RC0603FR-071K47L	Yageo America		
R109	3.57k	RES, 3.57 k, 1%, 0.1 W, 0603	0603	RC0603FR-073K57L	Yageo America		
R112, R113	13.7k	RES, 13.7 k, 1%, 0.063 W, AEC-Q200 Grade 0, 0402	0402	CRCW040213K7FKED	Vishay-Dale		
R116	40.2k	RES, 40.2 k, 1%, 0.1 W, AEC-Q200 Grade 0, 0402	0402	ERJ-2RKF4022X	Panasonic		
R117	1.00Meg	RES, 1.00 M, 1%, 0.1 W, 0603	0603	RC0603FR-071ML	Yageo America		
R118	162k	RES, 162 k, 1%, 0.1 W, 0603	0603	RC0603FR-07162KL	Yageo America		
R119	510	RES, 510, 1%, 0.1 W, 0402	0402	ERJ-2RKF5100X	Panasonic		
R125, R127	1.87k	RES, 1.87 k, 1%, 0.063 W, 0402	0402	RC0402FR-071K87L	Yageo America		
R130, R133	0	RES, 0, 5%, .05 W, AEC-Q200 Grade 0, 0201	0201	ERJ-1GN0R00C	Panasonic		

Table 4. PPC3-EVM-MB BOM (continued)

Designator	Value	Description	Package Reference	PartNumber	Manufacturer	Alternate Part Number	Alternate Manufacturer
R132	3.01	RES, 3.01, 1%, 0.1 W, 0603	0603	RC0603FR-073R01L	Yageo America		
S1		Switch, Tactile, SPST-NO, 0.05A, 12V, SMT	Switch, 4.4x2x2.9 mm	TL1015AF160QG	E-Switch		
SH-J1, SH-J2, SH-J3, SH-J4, SH-J5, SH-J6, SH-J7, SH-J8, SH-J9, SH-J10, SH-J11, SH-J12, SH-J13	1x2	Shunt, 100mil, Gold plated, Black	Shunt	SNT-100-BK-G	Samtec	969102-0000-DA	3M
TP1, TP2, TP3, TP4		Test Point, Miniature, Black, TH	Black Miniature Testpoint	5001	Keystone		
U1		IC MCU 512KB RAM, 128TQFP	TQFP-128	XEF216-512-TQ128-C20	XMOS semiconductor		
U2, U3, U4, U5, U17		Dual Buffer Gate, DRL0006A, LARGE T&R	DRL0006A	SN74LVC2G34DRLR	Texas Instruments		Texas Instruments
U6		Dual-Bit Dual-Supply Bus Transceiver, DQE0008A, LARGE T&R	DQE0008A	SN74AVC2T244DQER	Texas Instruments		
U7		Programmable 1-PLL VCXO Clock Synthesizer with 2.5-V or 3.3-V LVCMOS Outputs, PW0014A (TSSOP-14)	PW0014A	CDCE913PWR	Texas Instruments	CDCE913PW	Texas Instruments
U8		Single Channel, Ultra Small, Adjustable Supervisory Circuit with Active-High, Open-Drain Output, 1 Supply Monitored, -40 to 125 degC, 6-pin SON (DRY), Green (RoHS & no Sb/Br)	DRY0006A	TPS3897ADRYR	Texas Instruments		
U9		Enhanced Product Dual Buffer/Driver with Open-Drain Output, DCK0006A (SOT-SC70-6)	DSF0006A	SN74LVC2G07DSFR	Texas Instruments		
U10, U12, U14		Dual 1-of-4 FET Multiplexer/Demultiplexer 2.5-V/3.3-V Low-Voltage High-Bandwidth Bus Switch, RGY0016A (VQFN-16)	RGY0016A	SN74CB3Q3253RGYR	Texas Instruments		Texas Instruments
U11, U13, U19, U21, U23, U25, U28, U30, U38, U55		4-Bit Dual-Supply Bus Transceiver With Configurable Voltage-Level Shifting and 3-State Outputs, RSV0016A (UQFN-16)	RSV0016A	SN74AVC4T774RSVR	Texas Instruments		Texas Instruments
U15		Low-Voltage 8-Bit I2C and SMBus I/O Expander, 1.65 to 5.5 V, -40 to 85 degC, 16-pin UQFN (RSV), Green (RoHS & no Sb/Br)	RSV0016A	TCA6408ARSVR	Texas Instruments		
U16		Single 2-Line to 1-Line Data Selector/Multiplexer, DCT0008A, LARGE T&R	DCT0008A	SN74LVC2G157DCTR	Texas Instruments	SN74LVC2G157DCUT	Texas Instruments
U18, U24, U33, U52		Single Bus Buffer Gate With 3-State Outputs, DCK0005A, LARGE T&R	DCK0005A	SN74LVC1G125DCKR	Texas Instruments		
U20, U32, U39, U40, U44		4-Bit One-of-2 FET Multiplexer/Demultiplexer 2.5-V/3.3-V Low-Voltage, High-Bandwidth Bus Switch, DGV0016A (TVSOP-16)	DGV0016A	SN74CB3Q3257DGVV	Texas Instruments		Texas Instruments
U22, U49		Single 2-Input Positive-AND Gate, DCK0005A, LARGE T&R	DCK0005A	SN74LVC1G08DCKR	Texas Instruments		Texas Instruments
U26, U27, U47, U54		Low Distortion, Low Noise, General Purpose Audio Op Amp, DGK0008A (VSSOP-8)	DGK0008A	OPA1678IDGKR	Texas Instruments	OPA1678IDGKT	Texas Instruments
U29		Single Power Supply, Single BUFFER GATE w/ 3-State Output (active high enable), DCK0005A, LARGE T&R	DCK0005A	SN74LV1T126DCKR	Texas Instruments		
U31, U41, U56, U58		2-Bit Bidirectional 1-MHz I2C Bus and SMBus Voltage-Level Shifter, DCU0008A (VSSOP-8)	DCU0008A	TCA9406DCUR	Texas Instruments		
U34, U35, U36		High Speed, High Output Current, Dual Operational Amplifier, DDA0008B (SOIC-8)	DDA0008B	LM7372MRX/NOPB	Texas Instruments	LM7372MR/NOPB	Texas Instruments

Table 4. PPC3-EVM-MB BOM (continued)

Designator	Value	Description	Package Reference	PartNumber	Manufacturer	Alternate Part Number	Alternate Manufacturer
U37, U43, U57		Single 2-Line to 1-Line Data Selector/Multiplexer, DCU0008A, LARGE T&R	DCU0008A	SN74LVC2G157DCUR	Texas Instruments	SN74LVC2G157DCUT	Texas Instruments
U42		Single Output LDO, 400mA, Adj.(1.2 to 5.5V), Cap free, Low Noise, Reverse Current Protection, DBV0005A (SOT-23-5)	DBV0005A	TPS73618DBVR	Texas Instruments		
U45		3-A Step-Down Converter with DCS-Control and Hiccup Short Circuit Protection in 2x2 HotRod Package, RLT0007A (VSON-HR-7)	RLT0007A	TPS62085RLTR	Texas Instruments	TPS62085RLTT	Texas Instruments
U46		Automotive 112dB SNR Stereo ADC With Differential Inputs, DB0028A (SSOP-28)	DB0028A	PCM1804S1IDBRQ1	Texas Instruments		Texas Instruments
U48		3.5-MHz High Efficiency Step-Up Converter in Chip Scale Package, YFF0009ACAG (DSBGA-9)	YFF0009ACAG	TPS61256CYFFR	Texas Instruments	TPS61256CYFFT	Texas Instruments
U50		Single Nanopower Push-Pull Comparator, DBV0005A (SOT-23-5)	DBV0005A	TLV3701IDBVR	Texas Instruments	TLV3701IDBVT	Texas Instruments
U51		Single Schmitt-Trigger Inverter, DCK0005A, LARGE T&R	DCK0005A	SN74LVC1G14DCKR	Texas Instruments		
U53		3.5 to 36Vin, 3 Ampere Synchronous DC-DC Converter for Automotive Applications, PWP0016D (TSSOP-16)	PWP0016D	LM536033QPWPRQ1	Texas Instruments	LM536033QPWPTQ1	Texas Instruments
Y1		OSC, 24 MHz, 2.25 - 3.63 V, SMD	2x1.6mm	ASTMLPA-24.000MHZ-EJ-E-T	Abracon Corporation		
C77, C82	10µF	CAP, CERM, 10 µF, 35 V, ± 10%, X5R, 0805	0805	C2012X5R1V106K085AC	TDK		
C78, C83	100pF	CAP, CERM, 100 pF, 50 V, ± 1%, C0G/NP0, 0603	0603	06035A101FAT2A	AVX		
C118	680pF	CAP, CERM, 680 pF, 50 V, ± 1%, C0G/NP0, 0603	0603	06035A681FAT2A	AVX		
FID1, FID2, FID3, FID4, FID5, FID6		Fiducial mark. There is nothing to buy or mount.	N/A	N/A	N/A		
J9		Receptacle, Male, 3 Position, R/A, TH	Receptacle, Male, 3 Position, R/A, TH	PQG3MRA112	Switchcraft		
J20		Phono Jack, R/A, TH	Phono Jack, 13x27x22.8mm	CTP-019-8	Connect-Tech-Products		
R46, R47	0	RES, 0, 5%, 0.063 W, 0402	0402	ERJ-2GE0R00X	Panasonic		
R81	10.0k	RES, 10.0 k, 1%, 0.063 W, 0402	0402	RC0402FR-0710KL	Yageo America		
R105	0	RES, 0, 5%, 0.125 W, 0805	0805	ERJ-6GEY0R00V	Panasonic		

Revision History**Changes from Original (November 2018) to A Revision** **Page**

-
- Added Note 2
-

IMPORTANT NOTICE AND DISCLAIMER

TI PROVIDES TECHNICAL AND RELIABILITY DATA (INCLUDING DATASHEETS), DESIGN RESOURCES (INCLUDING REFERENCE DESIGNS), APPLICATION OR OTHER DESIGN ADVICE, WEB TOOLS, SAFETY INFORMATION, AND OTHER RESOURCES "AS IS" AND WITH ALL FAULTS, AND DISCLAIMS ALL WARRANTIES, EXPRESS AND IMPLIED, INCLUDING WITHOUT LIMITATION ANY IMPLIED WARRANTIES OF MERCHANTABILITY, FITNESS FOR A PARTICULAR PURPOSE OR NON-INFRINGEMENT OF THIRD PARTY INTELLECTUAL PROPERTY RIGHTS.

These resources are intended for skilled developers designing with TI products. You are solely responsible for (1) selecting the appropriate TI products for your application, (2) designing, validating and testing your application, and (3) ensuring your application meets applicable standards, and any other safety, security, or other requirements. These resources are subject to change without notice. TI grants you permission to use these resources only for development of an application that uses the TI products described in the resource. Other reproduction and display of these resources is prohibited. No license is granted to any other TI intellectual property right or to any third party intellectual property right. TI disclaims responsibility for, and you will fully indemnify TI and its representatives against, any claims, damages, costs, losses, and liabilities arising out of your use of these resources.

TI's products are provided subject to TI's Terms of Sale (www.ti.com/legal/termsofsale.html) or other applicable terms available either on ti.com or provided in conjunction with such TI products. TI's provision of these resources does not expand or otherwise alter TI's applicable warranties or warranty disclaimers for TI products.

Mailing Address: Texas Instruments, Post Office Box 655303, Dallas, Texas 75265
Copyright © 2019, Texas Instruments Incorporated