

REV	ECN NO:	B Y	DATE
A2	NEW-DWG	ING	10/01/15

NOTE
MATERIAL: PHOSPHOR BRONZE
CONTACTS: PBT+30% G.F. UL-0
SHELL : SEE TABLE
BACKSHELL:SPCC
MATING: 35N MAX.
WITHDRAWAL FORCE:10N MIN.
DURABILITY:1500 CYCLES MIN.
CURRENT-MAX[AMPS] 1.5A
VOLTAGE-MAX[VOLTS] 30V
WITHSTANDING VOLTAGE 500V AC
CONTACT RESISTANCE 30MΩ MAX.
INSULATION RESISTANCE 1000MΩ MIN.
CONTACTS: PLATED SEE TABLE
SHELL: NICKEL OVER ALL PLATING
TEMPERATURE RANGE -55°C~+85°C

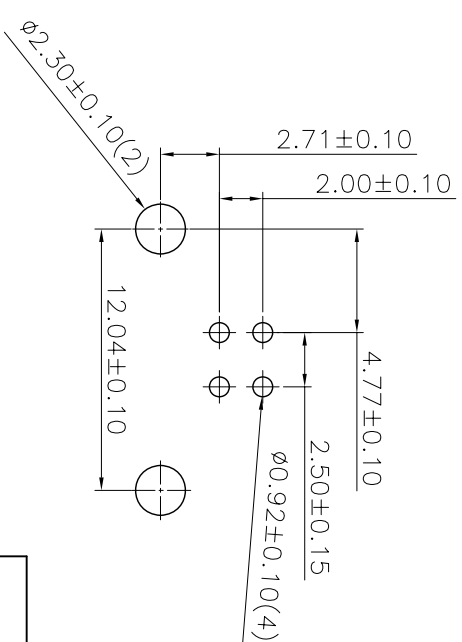
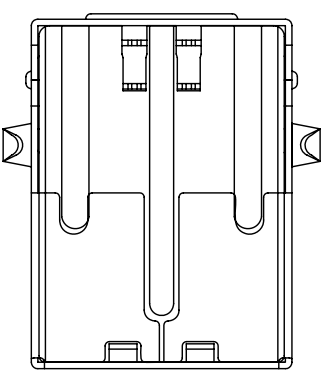
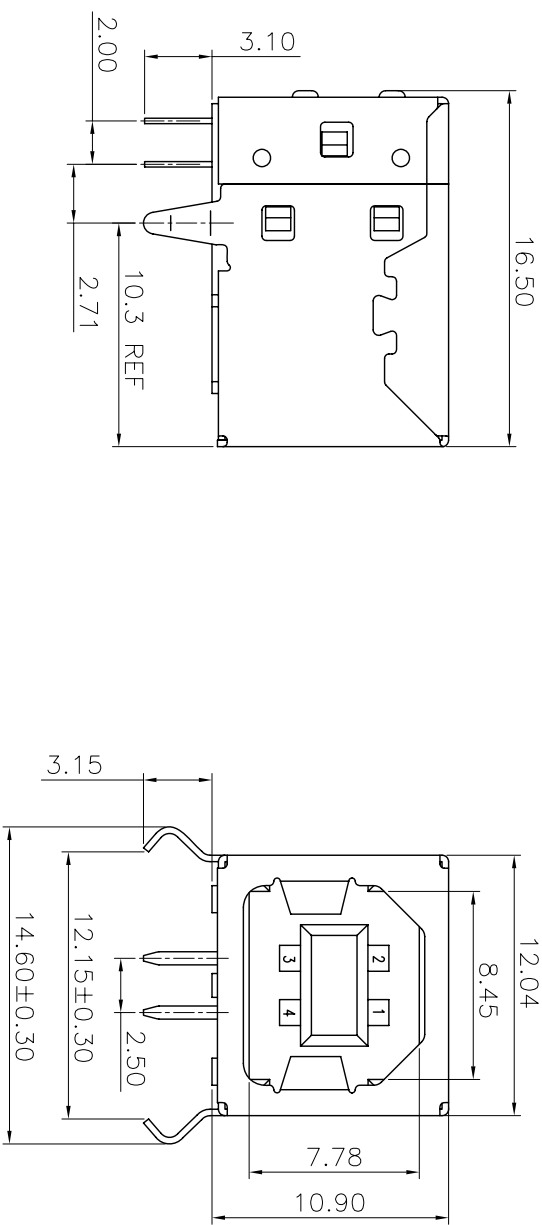

RECOMMENDED P.C.B. PATTERN LAYOUT

Cnc Tech,LLC

-TOLERANCES-
UNLESS OTHERWISE SPECIFIED

X.X ±0.38	X.X° ±2°	APPD:	TITLE:	USB BF 90°DIP封装
X.XX ±0.25	X.XX° ±1°	CHECK:	PRODUCT NO:	1002-003-02000
X.XXX ±0.13	X.XXX° ±0.5°	DRAW:	DATE	2010.01.15
			SCALE	FREE
			UNIT	MM
			TYPE	Z
			PAGE	1