

Amphenol
FCI

© 2016 APCI

spec ref	-	dr	Sunny2 Liu	2016/06/20	projection	MM	size	A2	scale	4:1	
tolerance std	ASME Y14.5	eng	Sunny2 Liu	2016/08/03		CARD EDGE	ecn no	-	rel level	Released	
TOLERANCES UNLESS OTHERWISE SPECIFIED		chr	Terris Liu	2016/08/02			cat. no.	-		Product - Customer Drw	sheet 1 of 4
surface	ASME Y14.5	linear	0.X	±0.5	Amphenol FCI		title	HPCE STMT RECPT		rev	A
		angular	0°	±°	HPCE STMT RECPT 4LP6HP12S		dwg no	10140115			

PDS: Rev :A

STATUS:Released

Printed: Aug 03, 2016

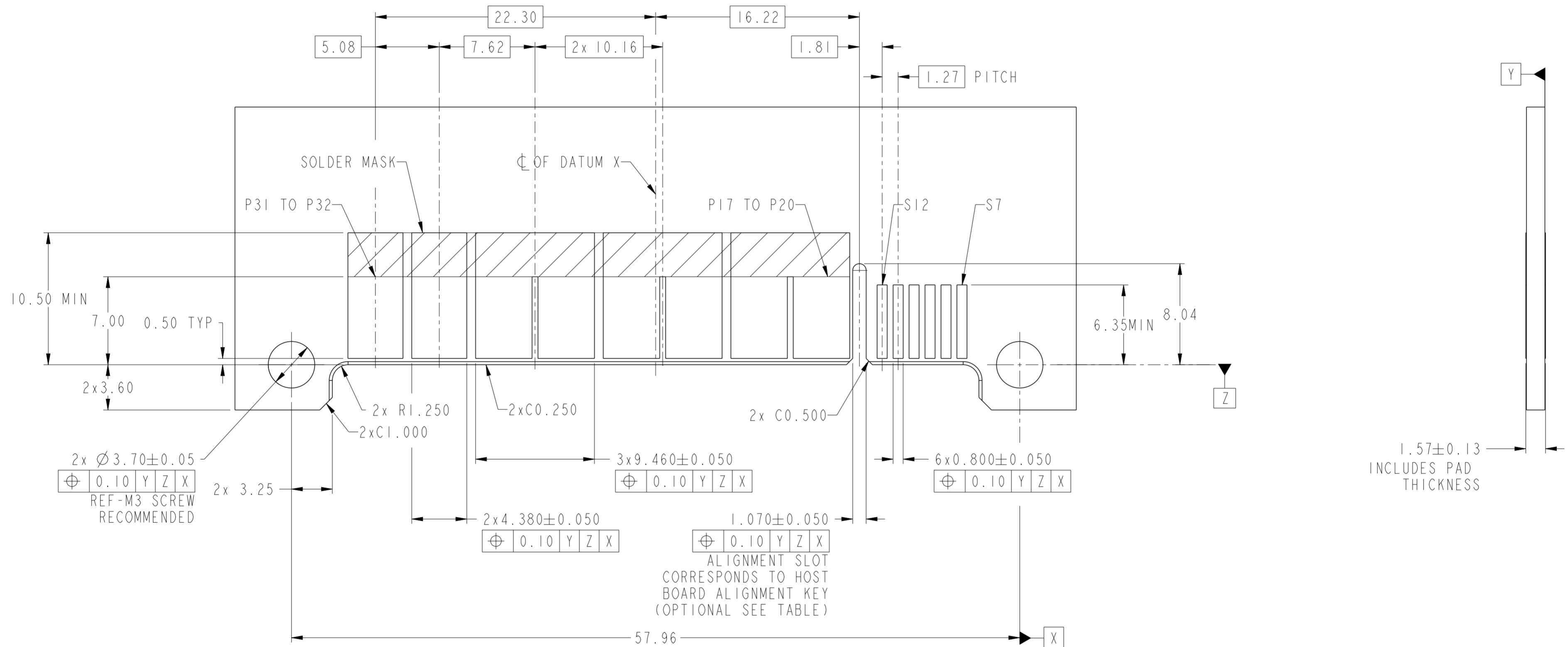

RECOMMENDED HOST BOARD LAYOUT
DIMENSION TOLERANCE IS 0.05MM

spec ref	-	dr	Sunny2 Liu	2016/06/20	projection	MM	size	A2	scale	2:1	
tolerance std	ASME Y14.5	eng	Sunny2 Liu	2016/08/03			ecn no	-			
TOLERANCES UNLESS OTHERWISE SPECIFIED		chr	Terris Liu	2016/08/02			rel level	Released			
surface	ASME Y14.5	appr	Pei-Ming Zheng	2016/08/03			product family	-	rel level	Released	
linear	0.X	±0.5	Amphenol FCI			title HPCE STMT RECPT 4LP6HP12S		dwg no 10140115		rev A	
	0.XX	±0.25									
	0.XXX	±0.10									
angular	0°	±°	cat. no.		Product - Customer Drw		sheet 2 of 4				

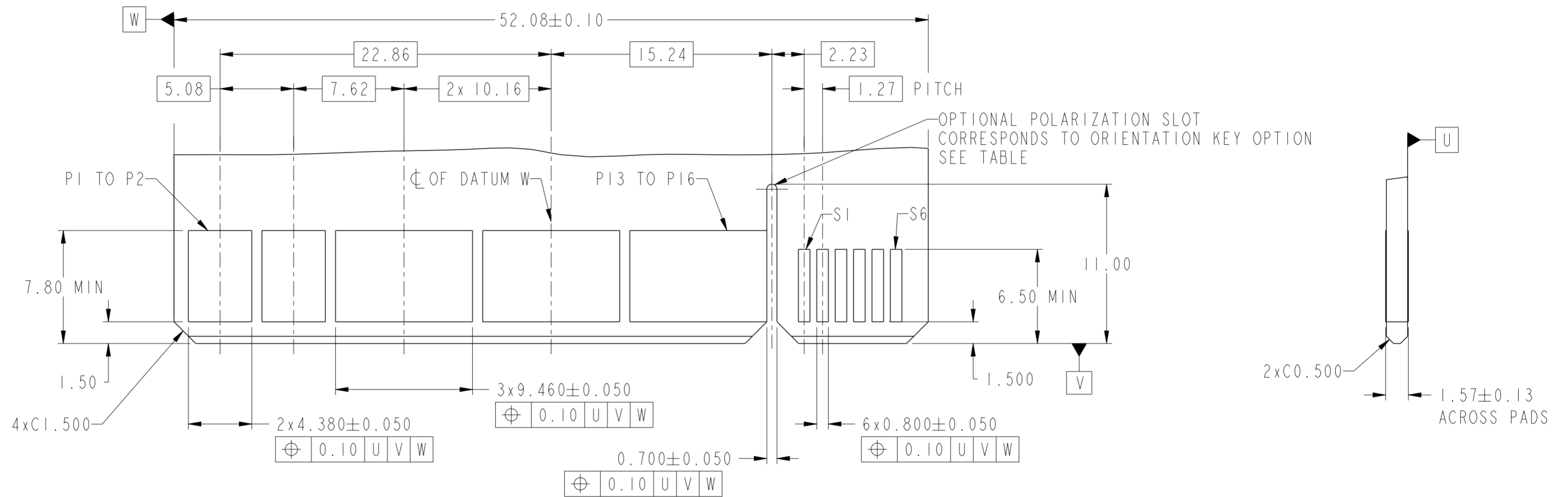

RECOMMENDED MATING BOARD LAYOUT
DIMENSION TOLERANCE IS 0.05MM

spec ref	-	dr	Sunny2 Liu	2016/06/20	projection	MM	size	A2	scale	1:1	
tolerance std	ASME Y14.5	eng	Sunny2 Liu	2016/08/03			ecn no	-	rel level	Released	
TOLERANCES UNLESS OTHERWISE SPECIFIED		chr	Terris Liu	2016/08/02							
		appr	Pai-Ming Zheng	2016/08/03							
surface	ASME Y14.5	linear	0.X	± 0.5			title	HPCE STMT RECPT		cat. no. Product - Customer Drw	sheet 3 of 4
		angular	0°	$\pm 0^\circ$	4LP6HP12S		10140115	rev A			

PART NUMBER	MOUNTING EARS	POLARIZATION KEY	REAR KEY
10140115-001LF	YES	YES	YES
10140115-002LF			NO
10140115-003LF		NO	YES
10140115-004LF	NO		

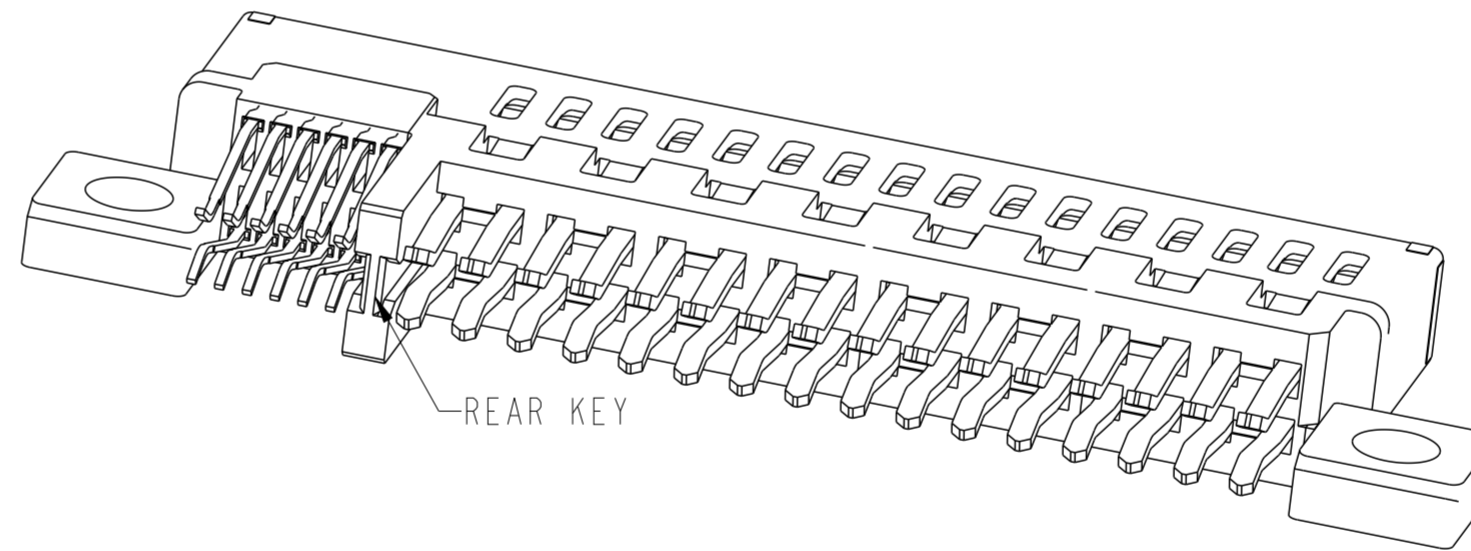
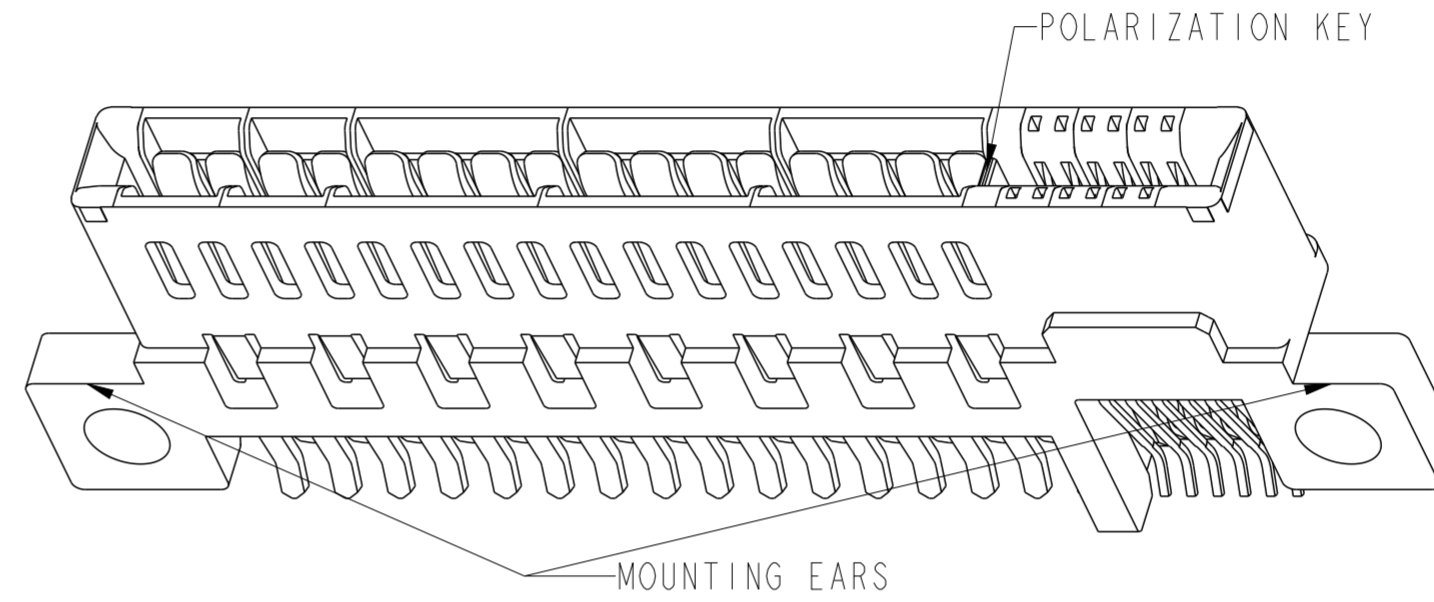

NOTES:

- CONNECTOR MATERIALS:
HOUSING: HIGH TEMPERATURE THERMAL PLASTIC, BLACK
UL 94V-0 COMPLIANT
CONTACTS: HIGH PERFORMANCE COPPER ALLOY.
- CONTACT FINISH REF. GS-12-604 SECTION 5.2.
- PRODUCT SPECIFICATION: GS-12-604.
- APPLICATION SPECIFICATION: GS-20-128.
- PRODUCT MARKING ON HOUSING IN AREA SHOWN MEETS FCI SPECIFICATION: GS-24-007.
- PACKAGING MEETS FCI SPECIFICATION: GS-14-937.
- HOST BOARD ALIGNMENT KEY IS RECOMMENDED TO ENSURE PROPER ALIGNMENT OF SOLDER TAILS WITH HOST BOARD PADS.

spec ref	-	dr	Sunny2 Liu	2016/06/20	projection	MM	size	A2	scale	4:1
tolerance std	-	eng	Sunny2 Liu	2016/08/03			ecn no	-	rel level	Released
ASME Y14.5	TOLERANCES UNLESS OTHERWISE SPECIFIED	chr	Terris Liu	2016/08/02						
surface	linear	appr	Pei-Ming Zheng	2016/08/03	product family	CARD EDGE	rel level	Released	cat. no.	Product - Customer Drw
ASME Y14.5	angular				Amphenol FCI	HPCE STMT RECPT	10140115	rev	A	sheet 4 of 4
						4LP6HP12S				