

GENERAL DESCRIPTION

The SX1781 is a high-performance low phase noise integer-N frequency synthesizer for wireless communications applications. The circuit embeds a fully integrated PLL (including VCO tank and loop filter), complementary output buffers. The divider and power-down settings are programmable via an SPI interface. A Lock Detector pin linked to a squelch function have been designed to ease the software development.

PIN DIAGRAM

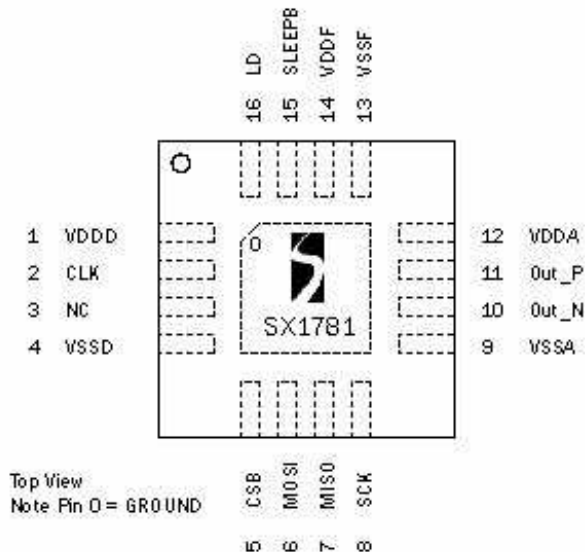

FEATURES

- ◆ Frequency range: 1200 to 1400 MHz
- ◆ Frequency step: 250 kHz min.
- ◆ Phase noise: -85 dBc/Hz @ 10 kHz offset
- ◆ Reference spurs: -67 dBc
- ◆ Hopping time: 350 μ s max.
- ◆ Operating voltage: 3.0 - 3.6V
- ◆ Programmable Output Power: up to +5 dBm
- ◆ Integrated VCO and loop filter
- ◆ SPI-bus interface
- ◆ Lock Detect output and squelch
- ◆ Ultra-low power sleep mode
- ◆ Complementary RF outputs
- ◆ Temperature range: -40 to +85°C
- ◆ 4 x 4 mm MLPQ16 package
- ◆ Pb-free and RoHS compliant

ORDERING INFORMATION

Part Number	Delivery	Quantity
SX1781IMLTRT	Tape & Reel	3000 pces

BLOCK DIAGRAM

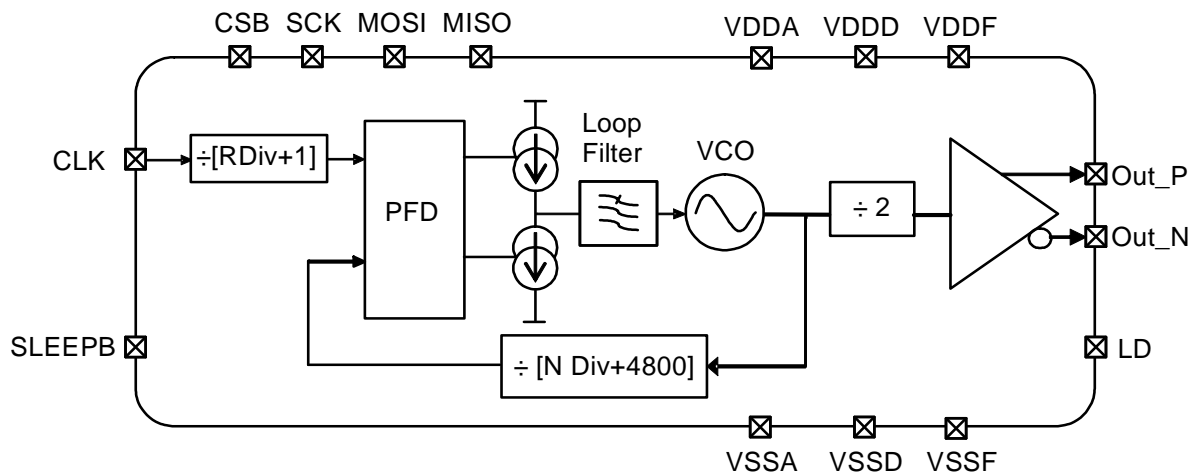

1. Pin Description

Table 1 Pin Description

Pin #	Pin Name	Pin Type	Description
1	VDDD		Power Supply
2	CLK	I	PLL Reference Signal
3	NC		Do not Connect
4	VSSD		Ground
5	CSB	I	SPI Line Select
6	MOSI	I	SPI Data Input
7	MISO	O	SPI Data Output (High Z when unused)
8	SCK	I	SPI Clock
9	VSSA		Ground
10	Out_N	O	RF Complementary Output
11	Out_P	O	RF Output
12	VDDA		Power Supply, Output Buffers
13	VSSF		Ground
14	VDDF		Power Supply
15	SLEEPB	I	When low, the circuit is in deep sleep mode
16	LD	O	PLL Lock Detect Output (active high)

Note: the thermal pad under the SX1781 should be connected to ground for an optimal thermal dissipation.

2. Electrical Characteristic

2.1. ESD and Latchup Notice

The SX1781 is a high performance radio frequency device. It withstands:

- ◆ 2 kV ESD discharge with the Human Body Model (Class 2 of the JEDEC standard JESD22-A114-B)
- ◆ 1 kV ESD discharge with the Charged Device Model (Class IV of JESD22-C101C)
- ◆ +/- 100 mA Static Latchup current at maximum temperature (Class II Level A of JESD78)



It should be handled with all the necessary ESD precautions to avoid any permanent damage.

2.2. Maximum Ratings

Important Note: The Absolute Maximum Ratings, in Table 1, are stress ratings only, and functional operation of the device at conditions other than those indicated in the Operating Conditions sections of this specification are not implied. Exposure to the absolute maximum ratings, where different to the operating conditions, for an extended period may reduce the reliability or useful lifetime of the product.

Table 2 Absolute Maximum Ratings

Parameter	Symbol	Minimum	Maximum	Units
Supply Voltage VDDA, VDDD, VDDF	V_{DD}	-0.5	3.7	V
Input Voltage (non-supply pins)	V_{in}	-	3.7	V
Output Voltage (non-supply pins)	V_{out}	-	3.7	V
Ambient Operating Temperature Range	TA	-40	+85	°C
Storage Temperature	Tstor	-50	+150	°C

2.3. Operating Conditions

Table 3 Operating Conditions

Parameter	Symbol	Minimum	Typical	Maximum	Units
Power Supply (DC voltage) VDDA, VDDD, VDDF	VDD	3.0	3.3	3.6	V
Ambient Temperature Range	TA	-40	-	+85	°C
Supply Current Inputs & Digital	I _{DDD}	-	3.1	4	mA
Supply Current Synthesizer only	I _{DDF}	-	10.8	12	mA
Supply Current RF output, lowest power ¹	I _{DDA}	-	8.1	-	mA
Supply Current RF output · maximum output power ¹	I _{DDA}	-	15	17	mA
Total Power Dissipation ²	P _{TOT}	-	95	125	mW
Standby Current (deep sleep mode)	I _{SLEEP}	-	0.25	3	uA

Note 1: Programmable output power. Must add I_{DDF}, I_{DDD}, & I_{DDA} for total device current consumption.

Note 2: Synthesizer with RF outputs enabled.

3. DC Characteristics

Table 4 *CSB, MOSI, SCK and SLEEPB Pins*

Parameter	Symbol	Minimum	Typical	Maximum	Units
Vin High	V_{IH}	2	-	-	V
Vin Low	V_{IL}	-	-	0.8	V
Input Leakage Current	I_{LEAK}	-1	-	1	μ A

Table 5 *MISO, LD Output Ports*

Parameter	Symbol	Minimum	Typical	Maximum	Units
Vout Low (IOL = 4mA)	V_{ol}	-		0.4	V
Vout High (IOH = 4mA)	V_{oh}	2.4	-	-	V
Drive Current	ID	-	-	4	mA

Note: MISO and MOSI have no internal pull-up/down. MOSI is in High-Z when not used.

4. AC and DC Characteristics

Table 6 *CLK Pin*

Parameter	Symbol	Minimum	Typical	Maximum	Units
Input impedance	Z_{in}	80	-	120	k Ω
Vin High, DC coupling at input	V_{IH}	2	-	-	V
Vin Low, DC coupling at input	V_{IL}	-	-	0.8	V
CLK amplitude, AC coupling at input	V_{AC}	0.5	-	VDD	Vp-p

Note: See Input Reference Signal section.

5. RF Characteristics

Table 7 RF Characteristics

Parameter	Symbol	Test Conditions	Minimum	Typical	Maximum	Units
CLK Input Reference Frequency	F_{REF}	External Reference	0.5	-	26	MHz
PFD Update Frequency (1)	f_{ϕ}	$f_{\phi} = F_{REF}/(Rdiv+1)$	500 (2)	-	-	kHz
VCO Center Frequency Range	F_{CEN}	-	2400	-	2800	MHz
PLL Output Frequency Range	F_{OUT}	-	1200	-	1400	MHz
Phase Noise at 10 kHz offset	-	$F_{out}=1290$ MHz $f_{\phi} = 500$ kHz $F_{REF}=26$ MHz	-	-85	-75	dBc/Hz
Integrated Jitter	-	100Hz to 100kHz	-	2.4	4	ps
Loop Bandwidth	-	Closed Loop	-	50	-	kHz
Harmonic Suppression	H2	Second Harmonic	-	-26	-20	dBc
Maximum RFOUT Power Level	P_{out}	Single output into 50 ohm	-	-1	-	dBm
		Differential outputs combined in a balun	-	+5	-	dBm
Output Power Tolerance	ΔP_{out}	-	-3	-	+3	dB
Output Reference Spurs	-	Offset = 500 kHz	-	-67	-	dBc
Output Spurs	-	All other spurs	-	-67	-	dBc
Hopping Time (3) across entire tuning range	t_{hop}	To +/- 1 ppm precision	-	-	500	μ s
		To LD pin rising edge	-	-	350	μ s
Power Up Request from SLEEPB rising (3) (input reference settled)	t_{pup}	To +/- 1 ppm precision	-	-	750	μ s
		To LD pin rising edge	-	-	625	μ s
Power Down Request to Synthesizer off Time	t_{pdn}	SLEEPB falling	-	-	100	ns

Notes:

1: Value of Rdiv is as programmed into the input divider

2: PFD update frequency should be maintained as close to 500 kHz as possible for optimum phase noise performance. Other divider values can be programmed to reduce the PFD update rate, but this is not recommended due to the internal loop bandwidth being preset @ 50kHz.

 3: No SPI access should be performed during t_{pup} or t_{hop} , while the VCO is being calibrated.

6. Serial Interface: Slave SPI

The device is configured with a serial microprocessor bus. Figure 1 and Figure 2 show the timing diagrams of write and read accesses. The serial interface is SPI compatible with a 16-bit word. The serial interface clock (SCK) is not required to run between accesses (i.e., when CSB = 1).

6.1. Read Register

To read the value of a configuration register the timing diagram below should be carefully followed by the uC.

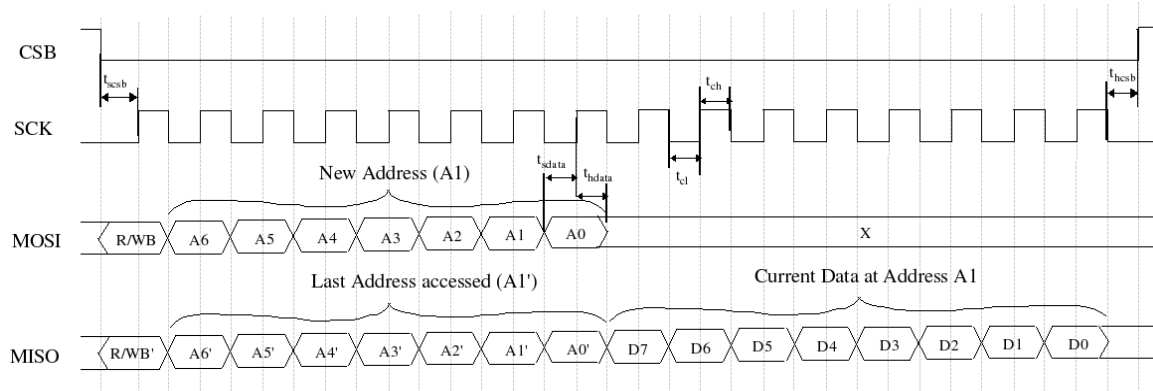

Figure 1. Read Register Timing

When reading more than one register successively, it is not compulsory to toggle CSB back high between two cycles. The bytes are alternatively considered as address and value.

MOSI: Master latches the address bit value on SCK falling edge and Slave samples the data on rising edge of SCK.

MISO: Slave latches the register bit value on falling edge of SCK and Master samples the value on the next rising edge.

Table 8 SPI Read Timings

Parameter	Symbol	Minimum	Typical	Maximum	Unit
SPI Clock Frequency	F _{sck}	-	-	20	MHz
Setup MOSI valid to SCK _{rising edge}	t _{sdata}	4	-	-	ns
Setup CSB _{falling edge} to SCK _{rising edge}	t _{scsb}	14	-	-	ns
Delay SCK _{falling edge} to MISO valid	t _{d1}	-	-	25	ns
Delay CS _B _{rising edge} to MISO high-Z	t _{d2}	-	25	-	ns
SCK Low time	t _{cl}	25	-	-	ns
SCK High time	t _{ch}	25	-	-	ns
Hold MOSI valid after SCK _{rising edge}	t _{hdata}	6	-	-	ns
Hold CSB Low after SCK _{rising edge}	t _{hcsb}	6	-	-	ns
Time between two accesses (CSB _{rising edge} to CSB _{falling edge})	t _p	25	-	-	ns

6.2. Write Register

To write a value into a configuration register the timing diagram below should be carefully followed by the uC.

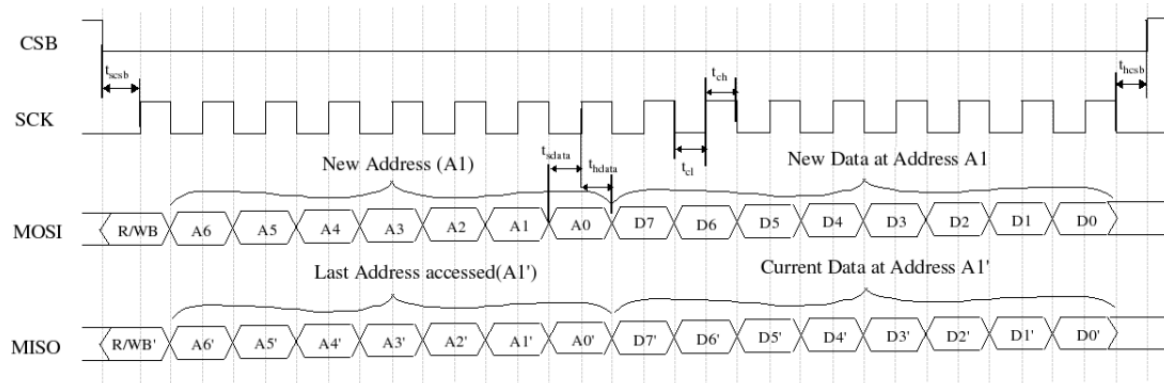

Figure 2. SPI Write Timing

Note that when writing more than one registers successively, it is not compulsory to toggle CSB back high between two cycles. The bytes are alternatively considered as address and value. In this instance, all new values will become effective on the rising edge of CSB.

The Master latches the data on SCK falling edge and Slave samples the data on rising edge of SCK.

MISO pin reflects the previous Write access. For the Write access, MISO stays low. MISO pin is tri-stated when CSB is high and when the device is in Sleep mode (SLEEPB is low).

Table 9 SPI Write Timings

Parameter	Symbol	Minimum	Typical	Maximum	Unit
SPI Clock Frequency	F _{sck}	-	-	20	MHz
Setup MOSI valid to SCK _{rising edge}	t _{sdata}	4	-	-	ns
Setup CSB _{falling edge} to SCK _{rising edge}	t _{sccb}	14	-	-	ns
Delay SCK _{falling edge} to MISO valid	t _{d1}	-	-	25	ns
Delay CSB _{rising edge} to MISO high-Z	t _{d2}	-	25	-	ns
SCK Low time	t _{cl}	25	-	-	ns
SCK High time	t _{ch}	25	-	-	ns
Hold MOSI valid after SCK _{rising edge}	t _{hdata}	6	-	-	ns
Hold CSB Low after SCK _{rising edge}	t _{hccb}	6	-	-	ns
Time between two accesses (CSB _{rising edge} to CSB _{falling edge})	t _p	25	-	-	ns

7. Input Reference Signal

The input reference signal of the PLL enters pin 2 CLK. To meet the phase noise performance of the synthesizer, the phase noise of the clock source (denoted PN_{CLK}) at a 10 kHz distance of the carrier should be such that:

$$PN_{CLK} < -160 + 20 \cdot \log(Rdiv+1) \text{ dBc/Hz @ 10 kHz}$$

A TCXO is an appropriate signal source at CLK input.

Two different connection schemes are possible, depending of the type of source :

- ◆ CMOS output device : the source should be directly DC connected to the CLK input, and its levels should be compliant with the specification of Table 6.
- ◆ Sine or clipped sine output: AC coupling, through a 560pF capacitor, should be used. In this case a minimum swing of 0.5 volts triggers the divider input (see Table 6).

8. RF Frequency Setting

The RF Output frequency is calculated from the following formula:

$$F_{out} = \frac{F_{ref}}{Rdiv+1} * \left[\frac{Ndiv + 4800}{2} \right]$$

Where

- ◆ Ndiv is controlled in a 10-bit register and Rdiv in a 6-bit register to be programmed through the SPI interface.
- ◆ Fref is the input reference frequency, of the signal applied on pin 2 (CLK). Note that the recommended value of $\frac{F_{ref}}{Rdiv+1}$ is 500 kHz, which allows for a minimum frequency step of 250 kHz.

9. Lock Detector and Squelch

A lock detection signal is mapped to pin 16 LD. It can be used as an interrupt request signal to the external world. This signal can also be used to internally shut down the output buffers until the PLL gets locked. This squelch function can be inhibited by setting bit 3 at address 3 to "1" (default = "0", squelch active).

10. Registers Description

The memory map of the registers is shown below.

Internal Address Register								Address byte	Register Name	Default value	Read Write
D7	D6	D5	D4	D3	D2	D1	D0				
NDiv[7:0]								0x00	RegNDivLsb	0x00	R/W
						NDiv[9:8]		0x01	RegNDivMsb	0x00	R/W
				RDiv[5:0]				0x02	RegRDiv	0x00	R/W
				Squelch	Cal_mode	Outp_config [1:0]		0x03	RegGenCtrl	0x00	R/W

Table 10 Memory Map of Registers

10.1. RegNDivLsb Register

This register is a read/write register. It configures the least significant 8-bits of Ndiv, the feedback divider ratio of the PLL. As writing RegNDivLsb triggers the calibration of the VCO, the user should first update RegNDivMsb, then configure RegNDivLsb if both need to be updated in a frequency hop. Doing this avoids wrong calibration sequences and extended lock times.

10.2. RegNDivMsb Register

This register is a read/write register. Bits [1:0] configure the two most significant bits of Ndiv, the feedback divider ratio of the PLL.

10.3. RegRDiv Register

This register is a read/write register. The five least significant bits configure the division factor of the Rdiv prescaler of the PLL.

10.4. RegGenCtrl Register

This register is a read/write register to configure the output and calibration modes.

Register Bits	Description
b[3]	RF out upon Lock Detection: 0 : The RF output is enabled only when the PLL is locked (Default) 1 : The RF output is enabled whatever the Lock detector state.
b[2]	Calibration mode 0 : Writing to RegNDivLsb triggers calibration (Default) 1 : Writing to RegRDiv or RegNDivLsb triggers calibration
b[1:0]	Output Buffer Current 00 : Output current is 3.5 mA (Default) 01 : Output current is 5 mA 10 : Output current is 7.5 mA 11 : Output current is 11 mA

11. Output Buffer

The SX1781 device embeds a differential output buffer structure.

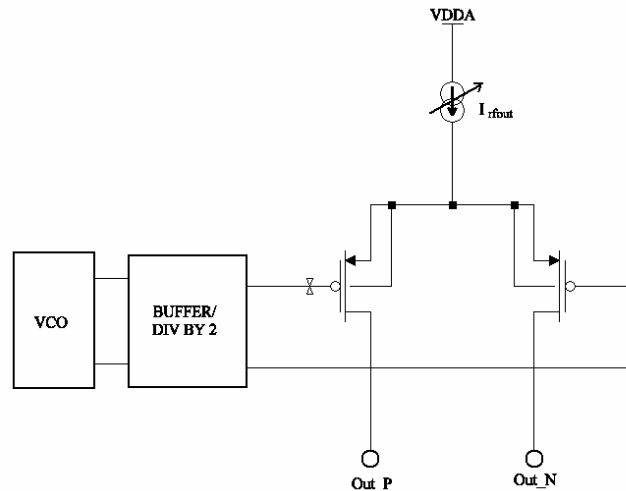

Figure 3. Output Buffer Structure

The output buffer structure described in Figure 3 allows using the SX1781 either single ended, or with the differential outputs combined in a balun, hence leading to a higher drive level.

11.1. Single Ended Configuration

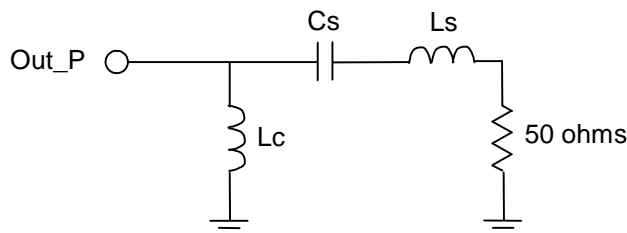

Figure 4. Single-Ended Output Setting

Figure 4 describes the single-ended output setting, enabling a typical output power of -1dBm in a reactive matched 50 ohm load, with the highest gain setting of the device. The choke inductor (denoted L_c) should be chosen to offer the highest impedance at the output frequency. Whenever using the chip in single-ended configuration, the unused complementary output should be terminated on a dissipative 50 ohms load.

11.2. Combined Differential Output

If additional power is required on a single-ended 50 ohms output port, the user can combine Out_P and Out_N outputs. Typical output powers of up to +5dBm can hence be reached. To achieve this, the lumped-lattice balun configuration of

Figure 5 offers the necessary bandwidth. Out_P and Out_N signal are shifted by $\pm 90^\circ$, thus combining on the single ended load, hence increasing the output power. The series inductors denoted L_p help cancel the parasitic capacitance of the package connections and DC bias is provided via the choke inductor L_c .

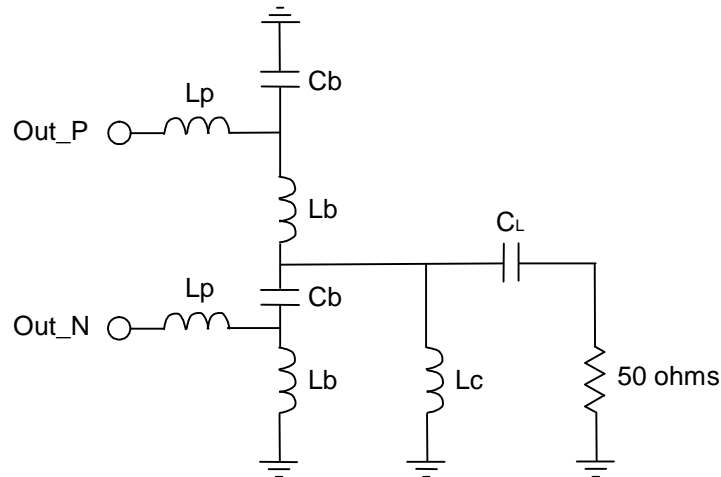

The following lumped elements values have shown to offer a reasonable output power over the 1.2 - 1.4 GHz range:

Label	Value	Unit	Comment
L_p	4.7	nH	Multilayer, its value sets the center frequency
L_b	2.7	nH	Multilayer
C_b	3.3	pF	COG
L_c	47	nH	Choke inductor, coil type
C_l	22	pF	AC link capacitor at 1.3 GHz

12. Application Schematics

The SX1781 is typically used as a local Oscillator in a superheterodyne transmitter or receiver.

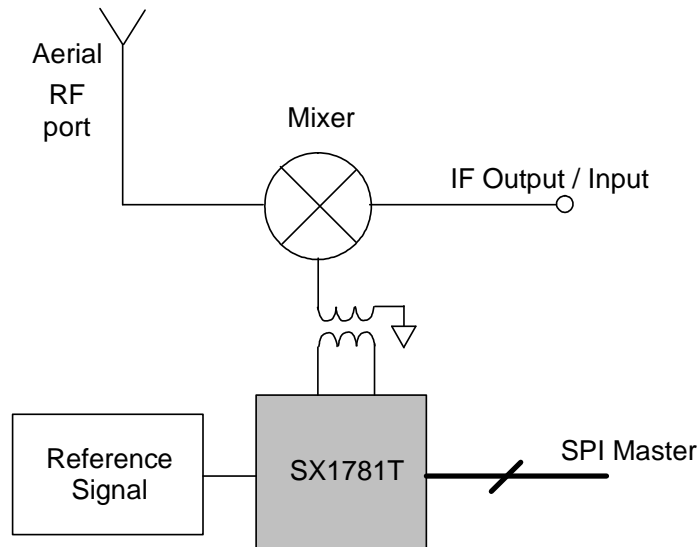
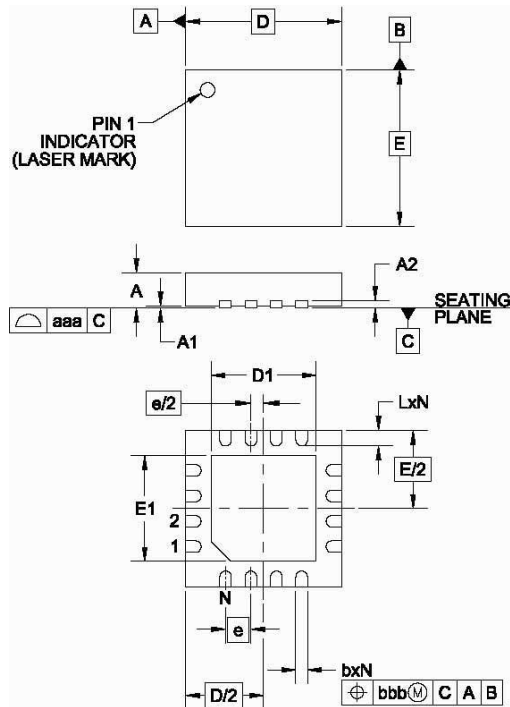

Figure 5. Application Example

13. Layout Information

13.1. Package Outline Drawing



DIM	DIMENSIONS					
	INCHES			MILLIMETERS		
	MIN	NOM	MAX	MIN	NOM	MAX
A	.031	-	.040	0.80	-	1.00
A1	.000	-	.002	0.00	-	0.05
A2	-	(.008)	-	-	(0.20)	-
b	.010	.012	.014	0.25	0.30	0.35
D	.153	.157	.161	3.90	4.00	4.10
D1	.100	.106	.110	2.55	2.70	2.80
E	.153	.157	.161	3.90	4.00	4.10
E1	.100	.106	.110	2.55	2.70	2.80
e	.026 BSC			0.65 BSC		
L	.012	.016	.020	0.30	0.40	0.50
N	16			16		
aaa	.003			0.08		
bbb	.004			0.10		

NOTES:

1. CONTROLLING DIMENSIONS ARE IN MILLIMETERS (ANGLES IN DEGREES).
2. COPLANARITY APPLIES TO THE EXPOSED PAD AS WELL AS THE TERMINALS
3. DAP IS 2.9 x 2.9 mm

13.2. Recommended land Pattern

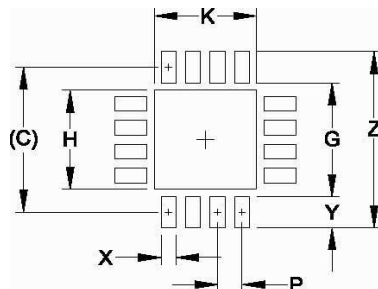

DIM	DIMENSIONS	
	INCHES	MILLIMETERS
C	(.156)	(3.95)
G	.122	3.10
H	.106	2.70
K	.106	2.70
P	.026	0.65
X	.016	0.40
Y	.033	0.85
Z	.189	4.80

NOTES:

1. CONTROLLING DIMENSIONS ARE IN MILLIMETERS (ANGLES IN DEGREES).
2. THIS LAND PATTERN IS FOR REFERENCE PURPOSES ONLY. CONSULT YOUR MANUFACTURING GROUP TO ENSURE YOUR COMPANY'S MANUFACTURING GUIDELINES ARE MET.
3. THERMAL VIAS IN THE LAND PATTERN OF THE EXPOSED PAD SHALL BE CONNECTED TO A SYSTEM GROUND PLANE. FAILURE TO DO SO MAY COMPROMISE THE THERMAL AND/OR FUNCTIONAL PERFORMANCE OF THE DEVICE.
4. SQUARE PACKAGE - DIMENSIONS APPLY IN BOTH "X" AND "Y" DIRECTIONS.

14. Revision Status / History

The Revision Status, as shown in top right corner of the datasheet, may be DRAFT, PRELIMINARY, or FINAL, and refers to the status of the Device (not the datasheet), with the design cycle. DRAFT status is used when the design is being realized but is not yet physically available, and the datasheet content reflects the intention of the design. The datasheet is raised to PRELIMINARY status when initial prototype devices are physically available, and the datasheet content more accurately represents the realization of the design. The datasheet is only raised to FINAL status after the device has been fully characterized, and the datasheet content updated with measured, rather than simulated parameter values.

Revision	Reference	Description of changes
1	14-Nov-08	First release of the Final version

© Semtech 2008

All rights reserved. Reproduction in whole or in part is prohibited without the prior written consent of the copyright owner. The information presented in this document does not form part of any quotation or contract, is believed to be accurate and reliable and may be changed without notice. No liability will be accepted by the publisher for any consequence of its use. Publication thereof does not convey nor imply any license under patent or other industrial or intellectual property rights. Semtech assumes no responsibility or liability whatsoever for any failure or unexpected operation resulting from misuse, neglect improper installation, repair or improper handling or unusual physical or electrical stress including, but not limited to, exposure to parameters beyond the specified maximum ratings or operation outside the specified range.

SEMTECH PRODUCTS ARE NOT DESIGNED, INTENDED, AUTHORIZED OR WARRANTED TO BE SUITABLE FOR USE IN LIFE-SUPPORT APPLICATIONS, DEVICES OR SYSTEMS OR OTHER CRITICAL APPLICATIONS. INCLUSION OF SEMTECH PRODUCTS IN SUCH APPLICATIONS IS UNDERSTOOD TO BE UNDERTAKEN SOLELY AT THE CUSTOMER'S OWN RISK. Should a customer purchase or use Semtech products for any such unauthorized application, the customer shall indemnify and hold Semtech and its officers, employees, subsidiaries, affiliates, and distributors harmless against all claims, costs damages and attorney fees which could arise.

Contact information

Semtech Corporation Advanced Communications & Sensing Products

E-mail: sales@semtech.com acsupport@semtech.com Internet: <http://www.semtech.com>

USA

200 Flynn Road, Camarillo, CA 93012-8790.
Tel: +1 805 498 2111 Fax: +1 805 498 3804

FAR EAST

12F, No. 89 Sec. 5, Nanking E. Road, Taipei, 105, TWN, R.O.C.
Tel: +886 2 2748 3380 Fax: +886 2 2748 3390

EUROPE

Semtech Ltd., Units 2 & 3, Park Court, Premier Way, Abbey Park Industrial Estate, Romsey, Hampshire, SO51 9DN.
Tel: +44 (0)1794 527 600 Fax: +44 (0)1794 527 601