

THIS DRAWING IS UNPUBLISHED. RELEASED FOR PUBLICATION  
 (C) COPYRIGHT 2006 BY TYCO ELECTRONICS CORPORATION. ALL RIGHTS RESERVED.

LOC	DIST	REVISIONS				
P	LTR	DESCRIPTION	DATE	DWN	APVD	
—	—	A	RELEASED	25JUN2008	MCC	RD

- 8. TYCO ELECTRONICS PN: 1857533-1
- 7. ITEMS PROVIDED TO THIS SPECIFICATION TO BE PERMANENTLY IDENTIFIED PER THE FOLLOWING IDENTIFIER:

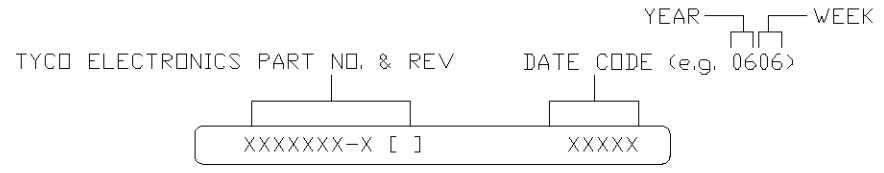

- 6. OUTLINE SPECIFICATION WHEN USED WITH MATING PC BOARDS DESIGNED (50Z COPPER) FOR COMPARIBLE OPERATION. (THIS INFORMATION TAKEN FROM C1766200)
  - CURRENT OF 17.5AMPS PER POWER CONTACT AT 30° TEMPERATURE RISE, 250VOLTS.
  - CURRENT OF 25AMPS PER POWER CONTACT UL.
  - CONNECTOR HOUSING GATHERABILITY OF 1.02 AT ZERO DEGREES PRIOR TO MATE.
  - MATING FORCES 15-20 POUNDS TYPICAL.
  - HEAT DEFLECTION TEMPERATURE, SHORT DURATION, ABOVE 235°C.
- 5. A REFERENCE DIMENSION (X.XX) IS WITHOUT TOLERANCE AND IS USED FOR INFORMATION PURPOSES ONLY.
- 4. SOCKET ACCEPTS 1.6 THICK PC BOARD TIN PLATED MIN OR 1.6 COPPER CONDUCTOR BLADE, NICKEL PLATED MIN.
- 3. FINISHES.  
 CONTACT PLATING: SELECTIVE GOLD PER 112-162-5, 0.0762 MICRONS THK OVER NICKEL PER 112-25-2, 1.27 MICRONS THK.  
 PCB TERMINATION: SELECTIVE TIN PLATE PER 112-65-1, 2.54 MICRONS THK OVER NICKEL PER 112-25-2, 1.27 MICRONS THK.
- 2. MATERIALS.  
 INSULTORS: THERMOPLASTIC, GLASS REINFORCED, UL94V-0, COLOUR BLACK.  
 CONTACTS: COPPER ALLOY.
- 1. PART NUMBER CHANGES AND/OR DESIGN CHANGES AFFECTING ITEM INTERCHANGEABILITY REQUIRES TYCO APPROVAL AND AUTHORIZATION BY REVISION TO THIS DRAWING.

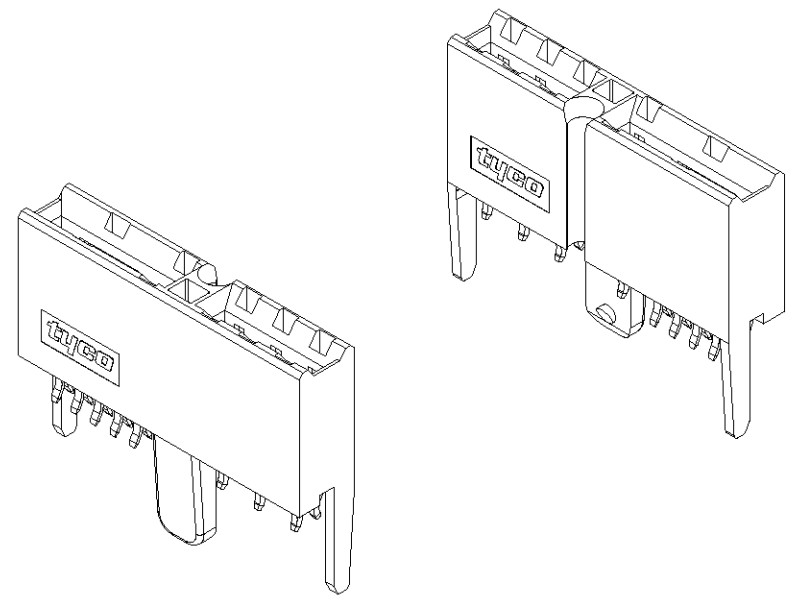

THIS DRAWING HAS BEEN REVIEWED AND APPROVED

SIGNED:.....

DATED:.....

NOTES: UNLESS OTHERWISE SPECIFIED.

THIS DRAWING IS A CONTROLLED DOCUMENT.		DWN M.C.CANT	08FEB06	<b>tyco</b> Electronics		Tyco Electronics Nederland BV 's-Hertogenbosch, Netherlands	
DIMENSIONS: mm		TOLERANCES UNLESS OTHERWISE SPECIFIED:		NAME		CROWNEDGE STRADDLEMOUNT CONNECTOR P2S8	
		0 PLC ± 1 PLC ± 0.25 2 PLC ± 0.08 3 PLC ± 4 PLC ± ANGLES ± 0.5		PRODUCT SPEC		SIZE	
MATERIAL		FINISH		APPLICATION SPEC		CAGE CODE	
				WEIGHT		DRAWING NO	
				CUSTOMER DRAWING		RESTRICTED TO	
				A3		00779	
				G-1857533			
				SCALE 2:1		SHEET 1 OF 4	
						REV A	

LOC		DIST		REVISIONS				
P	LTR	DESCRIPTION			DATE	DWN	APVD	
		SEE SHEET 1						

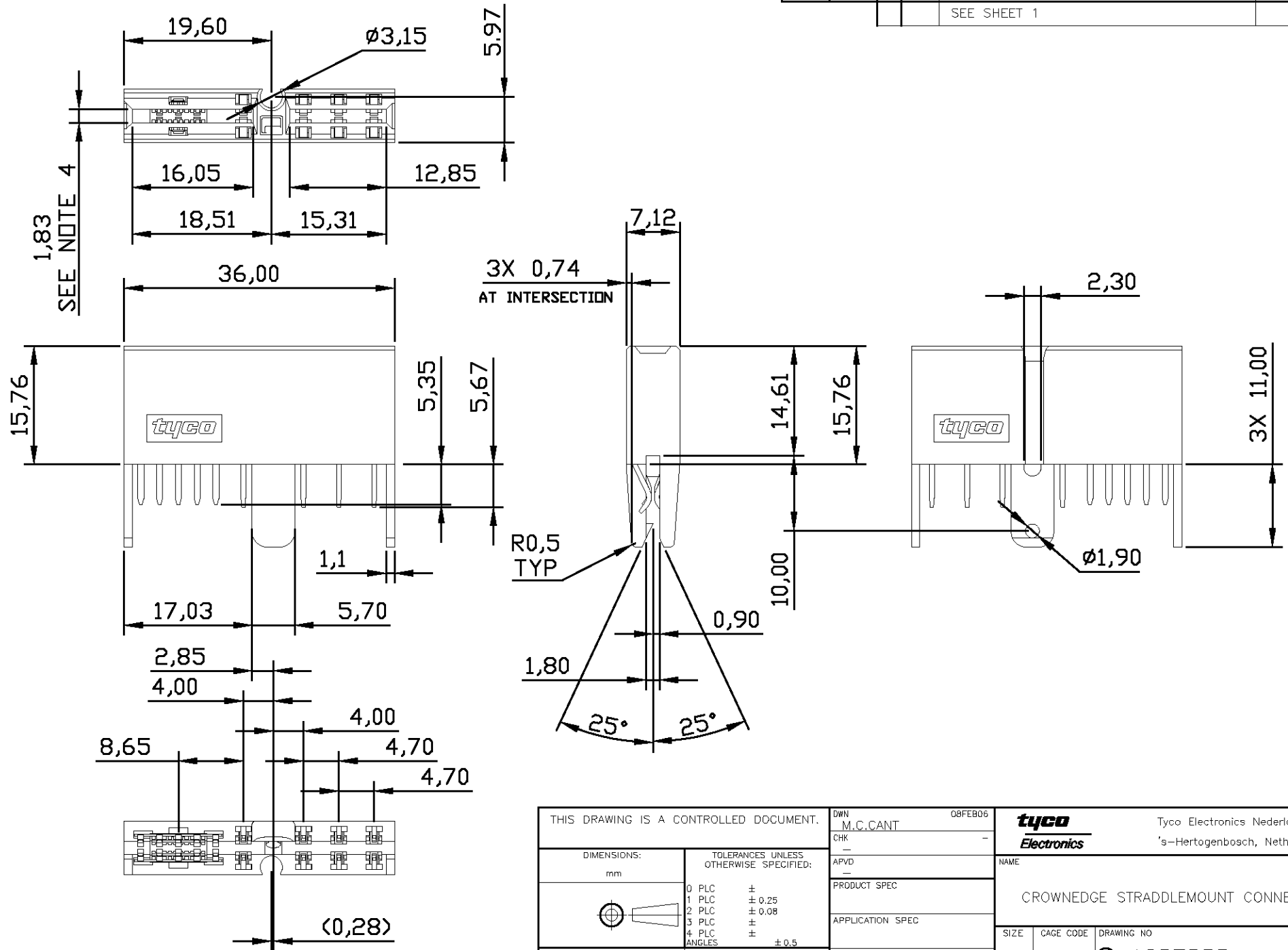

THIS DRAWING IS A CONTROLLED DOCUMENT.		DWN M.C.CANT	08FEB06	<b>tyco</b> Electronics		Tyco Electronics Nederland BV 's-Hertogenbosch, Netherlands	
DIMENSIONS: mm		TOLERANCES UNLESS OTHERWISE SPECIFIED:		NAME		CROWNEDGE STRADDLEMOUNT CONNECTOR P2S8	
<ul style="list-style-type: none"> <li>0 PLC ±</li> <li>1 PLC ± 0.25</li> <li>2 PLC ± 0.08</li> <li>3 PLC ±</li> <li>4 PLC ±</li> <li>ANGLES ± 0.5</li> </ul>		APVD		PRODUCT SPEC		RESTRICTED TO	
MATERIAL		FINISH		APPLICATION SPEC		SIZE	
				WEIGHT		CAGE CODE	
				DRAWING NO		DRAWING NO	
				A3 00779		1857533	
				CUSTOMER DRAWING		SCALE 2:1	
				SHEET 2 OF 4		REV A	

THIS DRAWING IS UNPUBLISHED. RELEASED FOR PUBLICATION  
 © COPYRIGHT 2006 BY TYCO ELECTRONICS CORPORATION. ALL RIGHTS RESERVED.

LOC		DIST		REVISIONS			
P	LTR	DESCRIPTION		DATE	DWN	APVD	
		SEE SHEET 1					

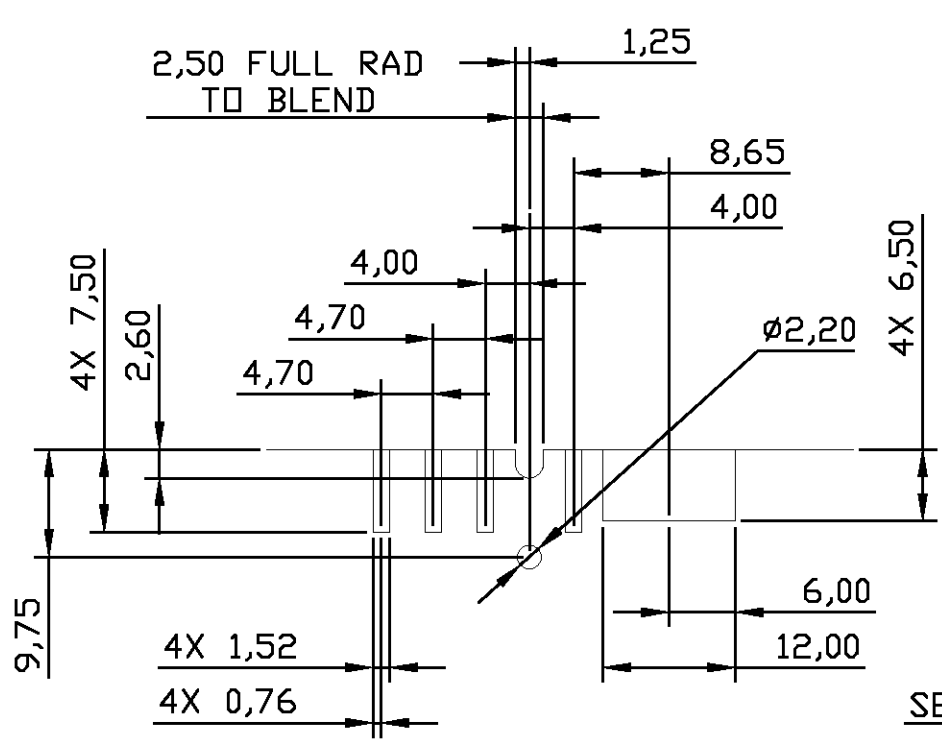

SUGGESTED MOUNTING  
PCB FOOTPRINT

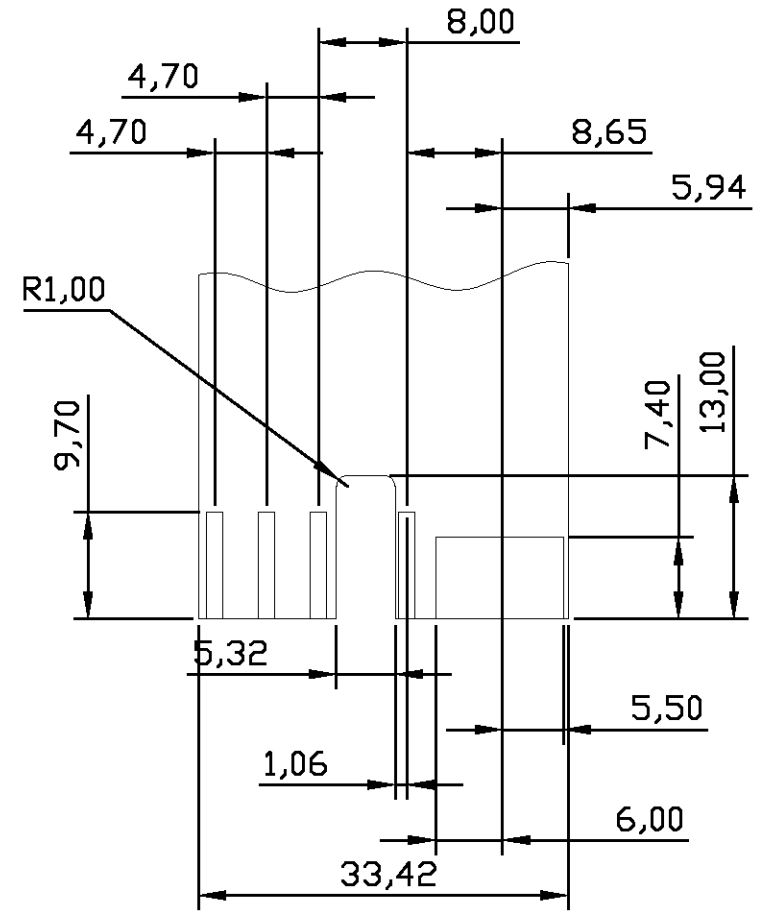

SUGGESTED MATING PCB  
OR BUSBAR PROFILE

THIS DRAWING IS A CONTROLLED DOCUMENT.		DWN M.C.CANT	08FEB06	<b>tyco</b> Electronics		Tyco Electronics Nederland BV 's-Hertogenbosch, Netherlands	
DIMENSIONS: mm		TOLERANCES UNLESS OTHERWISE SPECIFIED:		NAME		CROWNEDGE STRADDLEMOUNT CONNECTOR P2S8	
		0 PLC ± 1 PLC ± 0.25 2 PLC ± 0.08 3 PLC ± 4 PLC ± ANGLES ± 0.5		PRODUCT SPEC		SIZE CAGE CODE DRAWING NO RESTRICTED TO	
MATERIAL		FINISH		APPLICATION SPEC		A3 00779 C-1857533	
CUSTOMER DRAWING				SCALE 2:1		SHEET 3 OF 4 REV A	

THIS DRAWING IS UNPUBLISHED. RELEASED FOR PUBLICATION  
 © COPYRIGHT 2006 BY TYCO ELECTRONICS CORPORATION. ALL RIGHTS RESERVED.

LOC	DIST	REVISIONS			
P	LTR	DESCRIPTION	DATE	DWN	APVD
—	—	SEE SHEET 1			—

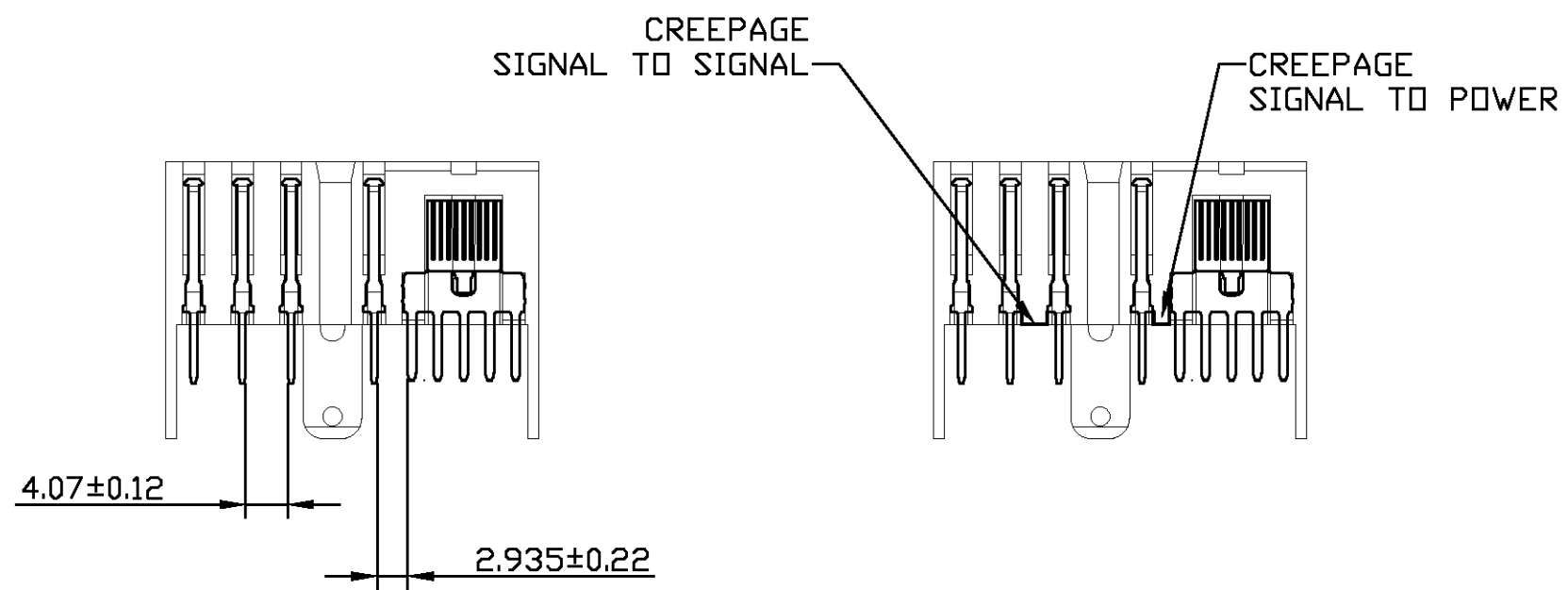

CREEPAGE & CLEARANCE VALUES FOR 1857533		
FEATURE	SIGNAL TO SIGNAL	SIGNAL TO POWER
CREEPAGE SHORTEST DISTANCE ALONG SURFACE	5.12 ±0.44	5.21 ±0.57
CLEARANCE SHORTEST DISTANCE IN AIR	4.07 ±0.12	2.935 ±0.22

THIS DRAWING IS A CONTROLLED DOCUMENT.		DWN M.C.CANT	08FEB06	<b>tyco</b> Electronics		Tyco Electronics Nederland BV 's-Hertogenbosch, Netherlands			
DIMENSIONS: mm		TOLERANCES UNLESS OTHERWISE SPECIFIED:		NAME CROWNEDGE STRADDLEMOUNT CONNECTOR P2S8 CREEPAGE & CLEARANCE VALUES FOR 1857533					
		0 PLC ±		PRODUCT SPEC					
		1 PLC ±0.25		APPLICATION SPEC					
MATERIAL		FINISH		WEIGHT		SIZE A3	CAGE CODE 00779	DRAWING NO 1857533	RESTRICTED TO
CUSTOMER DRAWING				SCALE	2:1	SHEET	4 OF 4	REV	A