



















- 1 
- 2 
- 3 
- 4 
- 5 
- 6 
- 7 
- 8 
- 9 
- 10 
- 11 
- 12 
- 13 
- 14 
- 15 
- 16 
- 17 
- 18 

MATERIAL
C10 zinc-plated steel.

RIVETS AND PINS
Zinc-plated steel.

HEXAGON-SOCKET HEAD SCREWS WITH COUNTERSINK FOR CYLINDER SUPPORT
Black-oxide steel.

CYLINDER SUPPORT BUSHINGS
Hardened steel.

ROTATING PIN AND SEEGER RINGS
Hardened and ground steel (for sizes ≥200).

STANDARD EXECUTIONS

- **PVA-AP3**: with open clamping lever and two folded washers.
- **PVA-APM**: with magnetic cylinder, open clamping lever and two folded washers.
- **PVA-EP3**: with solid clamping lever and retainer for welding.
- **PVA-EPM**: with magnetic cylinder, solid clamping lever and retainer for welding.

MAXIMUM WORKING PRESSURE
6 bars.

MAX WORKING TEMPERATURE
80°C.

CLAMPING BOLTS
To be ordered separately.

FEATURES AND APPLICATIONS
All articulated joints are lubricated with special grease.
Functioning principles of PVA. pneumatic clamps are the same as MVA. manual toggle clamps.
Executions PVA-APM and PVA-EPM (with magnetic cylinder), equipped with limit switches type PSW. (see page 1660) (to be ordered separately) gives drive and/or control impulses while active.
Using a lubrication filter assembly is necessary for the cylinder to work properly for a long time, whereas flow regulators are recommended to guarantee long life of mechanical components.

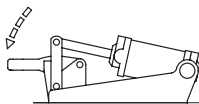

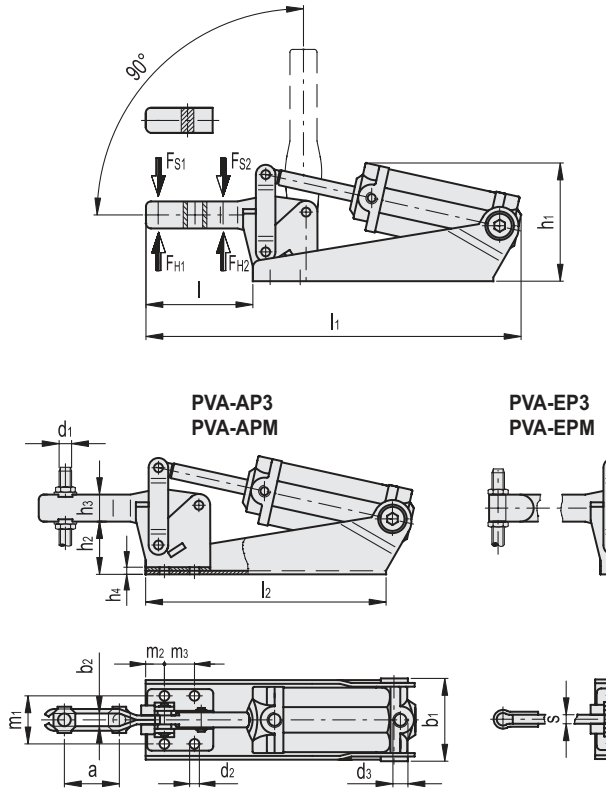

METRIC

PVA-AP3

Code	Description	a	b1	b2	d1	d2	d3	h1	h2	h3	h4	l	l1	l2	m1	m2	m3	FH1 [N]*	FH2 [N]*	FS1 [N]#	FS2 [N]#	⚖
GG.AO020	PVA.70-AP3	20	42	5.2	M5	4.5	G1/8	51.5	21	11	4	38	163	92	24	7	15	700	1450	500	750	500
GG.AO041	PVA.125-AP3	23	47.5	6.2	M6	5.5	G1/8	70.5	30	14	4.5	50	200	150	29	8	19	1600	3000	700	1200	700
GG.AO161	PVA.200-AP3	40	53	8.5	M8	6.5	G1/8	79	36	18	5.5	67.5	246	160	32	11	20	2200	3500	900	1500	1070
GG.AO201	PVA.300-AP3	42	74	10.5	M10	8.5	G1/4	98	48	20	8.5	78.5	304.5	195.5	46	11	29	2700	4500	1200	2400	2100
GG.AO301	PVA.400-AP3	66	74	12.5	M12	8.5	G1/4	107.5	51	22	10	110	360	216	45	10	32	3000	6400	1400	2600	3100

PVA-APM

Code	Description	a	b1	b2	d1	d2	d3	h1	h2	h3	h4	l	l1	l2	m1	m2	m3	FH1 [N]*	FH2 [N]*	FS1 [N]#	FS2 [N]#	⚖
GG.AO162	PVA.200-APM	40	53	8.5	M8	6.5	G1/8	79	36	18	5.5	67.5	246	160	32	11	20	2200	3500	900	1500	1070
GG.AO202	PVA.300-APM	42	74	10.5	M10	8.5	G1/4	98	48	20	8.5	78.5	304.5	195.5	46	11	29	2700	4500	1200	2400	2100
GG.AO302	PVA.400-APM	66	74	12.5	M12	8.5	G1/4	107.5	51	22	10	110	360	216	45	10	32	3000	6400	1400	2600	3100

PVA-EP3

Code	Description	b1	d1	d2	d3	h1	h2	h3	h4	l	l1	l2	l4	m1	m2	m3	s	FH1 [N]*	FH2 [N]*	FS1 [N]#	FS2 [N]#	⚖
GG.AO025	PVA.70-EP3	42	M5	4.5	G1/8	51.5	21	11	4	38	163	92	48	24	7	15	4	700	1450	500	750	500
GG.AO046	PVA.125-EP3	47.5	M6	5.5	G1/8	70.5	30	14	4.5	51	201	150	62	29	8	19	5	1600	3000	700	1200	700
GG.AO166	PVA.200-EP3	53	M8	6.5	G1/8	79	36	18	5.5	69.5	248	160	86	32	11	20	6	2200	3500	900	1500	1070
GG.AO206	PVA.300-EP3	74	M10	8.5	G1/4	98	48	20	8.5	80	306	195.5	95	46	11	29	8	2700	4500	1200	2400	2100
GG.AO306	PVA.400-EP3	74	M12	8.5	G1/4	107.5	51	22	10	112	362	216	130	45	10	32	10	3000	6400	1400	2600	3100

PVA-EPM

Code	Description	b1	d1	d2	d3	h1	h2	h3	h4	l	l1	l2	l4	m1	m2	m3	s	FH1 [N]*	FH2 [N]*	FS1 [N]#	FS2 [N]#	⚖
GG.AO167	PVA.200-EPM	53	M8	6.5	G1/8	79	36	18	5.5	69.5	248	160	86	32	11	20	6	2200	3500	900	1500	1070
GG.AO207	PVA.300-EPM	74	M10	8.5	G1/4	98	48	20	8.5	80	306	195.5	95	46	11	29	8	2700	4500	1200	2400	2100
GG.AO307	PVA.400-EPM	74	M12	8.5	G1/4	107.5	51	22	10	112	362	216	130	45	10	32	10	3000	6400	1400	2600	3100

* Holding force.
Clamping force ~4 bar

